



**Tools**



French manufacturer  
since 1964



# Auto Body Welding Equipment

2  
0  
2  
3



- SPOT WELDING
- DENT PULLER
- MIG
- PLASMA
- INDUCTION
- LIFT
- RIVETING
- BODYSHOP TOOLS





900 people



125 000 000



55 000 m<sup>2</sup>  
2 factories



visit with  
  
Youtube

# INVEST IN THE FUTURE

FR

Créé en 1964, GYS est un groupe industriel français regroupant plus de 900 collaborateurs dans le monde. Fort d'un centre de recherche de premier plan, GYS est un acteur majeur dans la conception et la fabrication d'équipements de soudage, de chargeurs de batteries et de systèmes de réparation carrosserie.

Les nouvelles réalités du marché sont en perpétuel changement et la taille de notre entreprise familiale nous impose une adaptation rapide aux nouveaux contextes et à leurs enjeux.

Nous sommes convaincus que notre avenir est étroitement lié à celui de nos clients. Pour cela, nous mettons tout en oeuvre pour comprendre ce que les distributeurs et les utilisateurs attendent de nous, savoir à quels défis ils font face et voir dans quelle mesure nous pouvons leur permettre de les relever afin de devenir et rester leur partenaire privilégié pour le chemin que nous avons à parcourir ensemble.

DE

GYS wurde 1964 gegründet und ist ein französisches Familienunternehmen mit mehr als 900 Mitarbeitern auf der ganzen Welt. Dank einem erstklassigen Forschungszentrum ist GYS ein wichtiger Akteur in der Entwicklung und Herstellung von Schweißgeräten, Batterieladegeräten und Karosseriereparatursystemen.

Neue Marktbedingungen sind in fortwährender Veränderung und die Größe unseres Familienunternehmens veranlasst eine rasche Anpassung an neue Umstände und an ihre Herausforderungen.

Wir sind überzeugt, dass unsere Zukunft eng mit der unserer Kunden verbunden ist. Dafür setzen wir all unser Können ein, um zu verstehen, was die Händler und Anwender von uns erwarten, welchen Herausforderungen sie gegenüberstehen und um zu schauen, in welchem Maße wir sie unterstützen können, damit wir ihr bevorzugter Partner werden und bleiben auf dem Weg, den wir gemeinsam beschreiten.

IT

Nato nel 1964, GYS è un gruppo industriale francese che raggruppa oltre 900 collaboratori nel mondo. Forte di un centro di ricerca di grande importanza, GYS è uno dei maggiori protagonisti nella progettazione e fabbricazione di apparecchiature per la saldatura e il taglio, di cariche batterie booster e avviatori e sistemi di riparazione delle carrozzerie.

Le realtà del mercato sono in continuo cambiamento e richiedono risposte immediate. Le dimensioni della nostra impresa familiare consentono un adattamento rapido ai nuovi contesti e alle loro problematiche.

Siamo convinti che il nostro futuro sia strettamente legato a quello dei nostri clienti. Per questo noi mettiamo il massimo impegno per capire quello che i distributori e i loro clienti/utilizzatori si aspettano da noi, quali sfide devono affrontare e come possiamo aiutarli per farli crescere, per diventare e restare loro partner di riferimento per proseguire insieme sul cammino del successo.

Created in 1964, GYS is a French industrial group with 900 employees around the world. Built around continuous investment in Research & Development and in the acquisition of knowledge, the company is now a major player in the design and manufacture of welding machines, battery chargers and car body repair equipment.



Nicolas & Bruno Bouygues

“ The market realities are constantly changing and the size of our family business requires us to quickly adapt to new contexts and new challenges.

We are convinced that our future is closely linked to the future of our partners. This is why we do everything in our power to understand what distributors and users expect from us and what challenges they face every day. To support them in facing these challenges, we wish to become and remain their privileged partner on the path we will travel together. ”

Bruno Bouygues,  
C.E.O.

## A worldwide coverage

132 countries



**GYS FRANCE**  
Laval

🕒 1964  
👤 × 650

**GYS GERMANY**  
Aachen

🕒 2006  
👤 × 75

**GYS U.K.**  
Rugby

🕒 2008  
👤 × 40

**GYS CHINA**  
Shanghai

🕒 2004  
👤 × 110

**GYS ITALIA**  
Venezia

🕒 2015  
👤 × 25

**GYS IBERICA**  
Madrid

🕒 2022  
👤 × 6

### Partners





# GYS ACADEMY

Training centre dedicated  
to professionals

Centre de formation agréé

Trainingcenter für Profis

Centro di formazione dedicato  
ai professionisti

Ref. 52 53 0068153



 **Advanced  
R&D**

 **x 90**



Metal work  
Tôlerie  
Blechbearbeitung



Painting & marking  
Peinture & marquage  
Lackierstraße



Electronics  
Électronique  
Elektronik



Mechanical  
Mécanique  
CNC-Bearbeitung

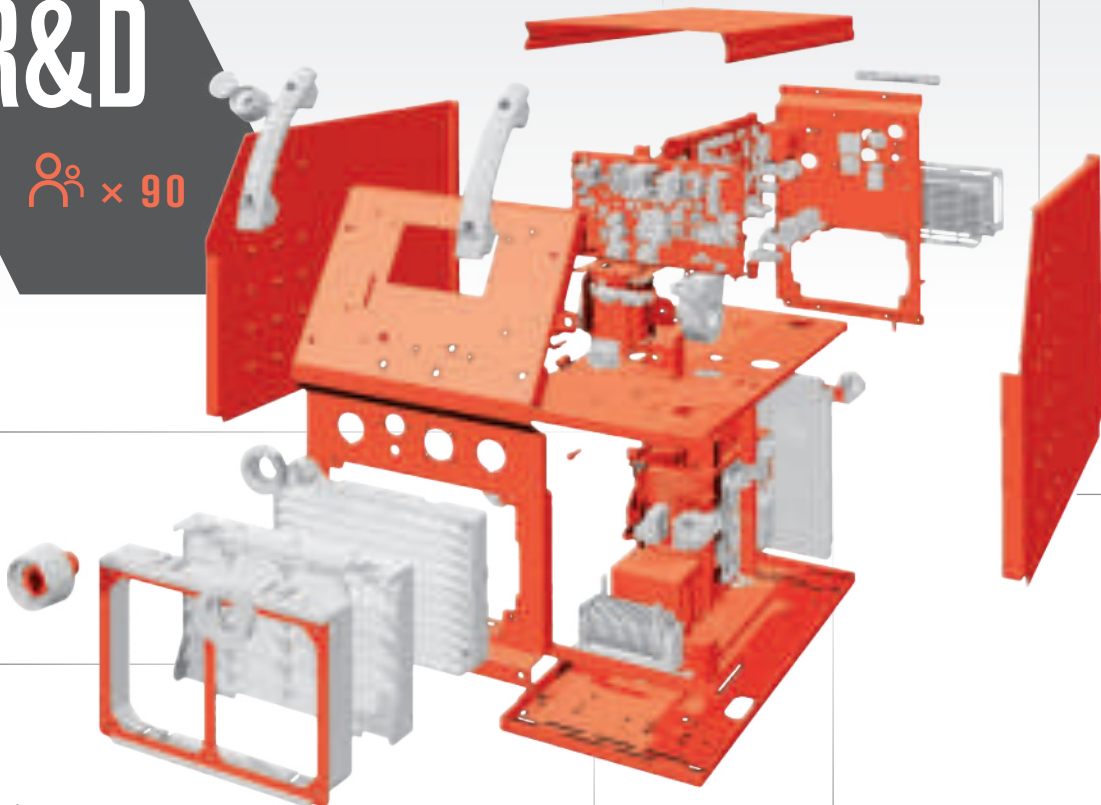

Assembly  
Montage/tests  
Montage



Transformers  
Transformateurs  
Transformatoren



Cable work  
Filerie  
Kabelkonfektionierung



# 3 catalogues

3200+ references



Welding  
& Cutting



Car Body  
Welding  
Systems



Chargers,  
Boosters  
& Starters

## DENT PULLING



**NEW**

GYSPOT  
p.6

Accessories,  
levelling bars  
p.20



Workstations  
p.24



Pulling systems  
p.32

Paintless repair  
p.38

## MOBILE LIFT



TROLLEY IW1  
p.41



MULTITOOL TRUCK  
p.41



SPOT LIFT  
p.42



AUTO ROLL  
& accessories  
p.42



ERGO LIFT  
& accessories  
p.44

## SPOT WELDING

Overview  
p.47

### Traditional



PORTASPOT  
p.48



GYSPOT 32D  
p.48

### Inverter



GYSPOT 100R  
p.49



GYSPOT BP & PTI  
p.50

X & C Arms  
p.52

### Genius



GYSPOT GENIUS  
p.55

G Arms  
p.60

Consumables  
& accessories  
p.61

## RIVETING



**NEW**

GYSPRESS  
p.62

Accessories  
& consumables  
p.68



## MIG WELDING



GYS AUTO  
p.74



**NEW**

AUTOGYS  
p.76



AUTOPULSE  
p.78

Helmets, accessories  
& consumables  
p.84

## INDUCTION



GYSDUCTION  
COMBIDUCTION  
p.90



POWERDUCTION  
p.92



## PLASMA



CUTTER & EASYCUT  
p.96

## + MORE

Windscreen repair p.98

Bumper repair p.100

Tools p.102

Dust vacuum p.107 **NEW**

Working lights p.108

Working supports p.110

Safety protections p.112

# 100%

in house  
production



GYSPOT

# DENT PULLING

## ACIER / STEEL / STAHL

- ▼ Étoiles - Stars - Ausbeulstern
- 🔗 Anneaux - Rings - Zugösen
- 〰 Filis ondulés - Wavy wires - Wellendraht
- 🔧 Rabattage d'impact - Impact shrinking - Glätten

### OPTIONS

Consommables - Consumables p.10



Chariots - Trolleys p.23



**NEW DESIGN**  
COMING SOON

- ▼ Étoiles - Stars - Ausbeulstern
- 🔗 Anneaux - Rings - Zugösen
- 〰 Filis ondulés - Wavy wires - Wellendraht
- 🔧 Rabattage d'impact - Impact shrinking - Glätten
- + 🔧 Rétreinte - Tempering - Temperieren



**FIXED GUN**

**FIXED GUN**

GYSPOT 2600

**2600 A** x1 **AUTOMATIC**

230V • 1~

052208

included

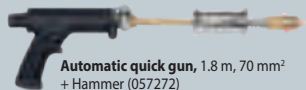

Automatic quick gun, 1.8 m, 70 mm<sup>2</sup>  
+ Hammer (057272)

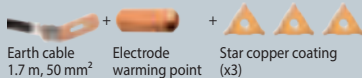

Earth cable 1.7 m, 50 mm<sup>2</sup>    Electrode warming point    Star copper coating (x3)

GYSPOT 2700

**2600 A** x1 **MANUAL**

230V • 1~

055353

included

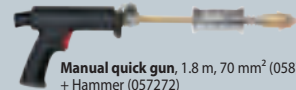

Manual quick gun, 1.8 m, 70 mm<sup>2</sup> (058705)  
+ Hammer (057272)

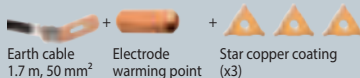

Earth cable 1.7 m, 50 mm<sup>2</sup>    Electrode warming point    Star copper coating (x3)

GYSPOT 34.02 & 34.04

**3500 A** x1 **MANUAL**

230V • 1~

**GYSPOT 34.02**  
065741

400V • 2~

**GYSPOT 34.04**  
067943

included

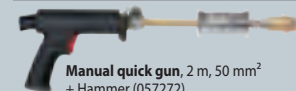

Manual quick gun, 2 m, 50 mm<sup>2</sup>  
+ Hammer (057272)

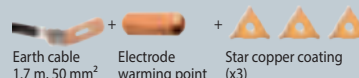

Earth cable 1.7 m, 50 mm<sup>2</sup>    Electrode warming point    Star copper coating (x3)

### QUICK GUNS

**Quick & Easy**

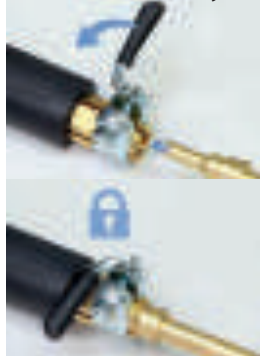

### **AUTOMATIC**



**WITH CONNECTOR**  
2 m, Ø 70 mm<sup>2</sup>  
included 39.02/04  
057517



**WITH CONNECTOR**  
3 m, Ø 50 mm<sup>2</sup>  
included PRO 230/400  
057500

**WITH CONNECTOR**  
3 m, Ø 70 mm<sup>2</sup>  
included EXPERT 200/230/400  
059207

### **MANUAL**



**WITH CONNECTOR**  
cable 2 m, Ø 70 mm<sup>2</sup>  
included PRO 230/400,  
EXPERT 200/230/400,  
COMBI 230EPRO  
057524

**No connector**  
cable 1.8 m, Ø 70 mm<sup>2</sup>  
for 2700  
058705

**No connector**  
cable 2 m, Ø 50 mm<sup>2</sup>  
for 34.02/34.04

PATENTS REGISTERED NUMBERS  
001830845-0001  
EUROPEAN TRADEMARK & DESIGN



- Étoiles - Stars - Ausbeulstern
- Anneaux - Rings - Zugösen
- Fils ondulés - Wavy wires - Wellendraht
- Rabattage d'impact - Impact shrinking - Glätten
- Rétreinte - Tempering - Temperieren
- Rivets - Rivets - Nieten
- Rondelles - Rings - Unterlegscheiben
- Goujons - Studs - Gewindebolzen

**SYNERGIC CONTROL** PATENTS REGISTERED NUMBERS EUROPEAN TRADEMARK & DESIGN



Welding current adjustment      Welding time adjustment



**GUN WITH CONNECTOR**

**GYSPOT 39.02 & 39.04**

<b>3800 A</b>	x1 <b>AUTOMATIC</b>
230V • 1~	<b>GYSPOT 39.02</b> 052215
400V • 2~	<b>GYSPOT 39.04</b> 052222

included

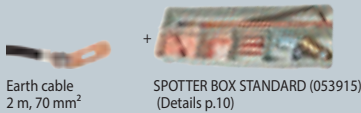
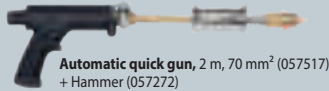

**GYSPOT PRO 230 & PRO 400**

<b>3800 A</b>	x2	<b>AUTOMATIC</b> <b>MANUAL</b>
230V • 1~	<b>GYSPOT PRO 230</b> 052178	
400V • 2~	<b>GYSPOT PRO 400</b> 052185	

included

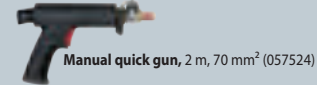
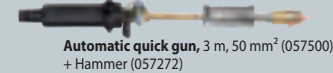

**GYSPOT EXPERT 200, 230 & 400**

<b>3800-4500 A</b>	x2	<b>AUTOMATIC</b> <b>MANUAL</b>
230V • 1~	<b>GYSPOT EXPERT 230</b> 066885	
200-240V • 1~	<b>GYSPOT EXPERT 200</b> 058842	
4350 • 5100 A		
400V • 2~	<b>GYSPOT EXPERT 400</b> 058859	
4500 A		

included

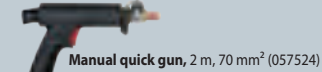
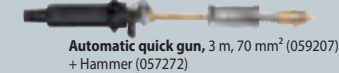

				I <sub>2</sub> max	U <sub>2</sub>		I <sub>RMS</sub>	kW				SYNERGIC					SEPARATE CABLE GUN			
																				50/60 Hz
MADE IN GYS CHINA	<b>GYSPOT 2600</b>	230V	2 m	2600	5,4	16	1800	10	OK	—	■	—	—	—	—	—	—	20 x 32 x 18	15	
	<b>GYSPOT 2700</b>	230V	2 m	2600	5,4	16	1800	10	OK	—	■	—	■	—	—	—	—	20 x 32 x 18	14.5	
	<b>GYSPOT 34.02</b>	230V	2 m	3500	7,4	16	2500	20	OK	OK	■	—	■	■	—	■	—	22,5 x 36 x 23,5	21	
	<b>GYSPOT 34.04</b>	400V, 2ph	4 m	3500	7,4	16	2500	20	OK	OK	■	—	■	■	—	■	—	22,5 x 36 x 23,5	21	
MADE IN FRANCE	<b>GYSPOT 39.02</b>	230V	4 m	3800	7,4	16	2800	20	OK	OK	—	■	■	■	■	—	■	22,5 x 36 x 23,5	22	
	<b>GYSPOT 39.04</b>	400V, 2ph	4 m	3800	7,4	16	2800	20	OK	OK	—	■	■	■	■	—	■	22,5 x 36 x 23,5	22	
	<b>GYSPOT PRO 230</b>	230V	8 m	3800	7,4	16	2800	20	OK	OK	—	■	■	■	■	■	■	22,5 x 36 x 23,5	20.5	
	<b>GYSPOT PRO 400</b>	400V, 2ph	8 m	3800	7,4	16	2800	20	OK	OK	—	■	■	■	■	■	■	22,5 x 36 x 23,5	20.5	
	<b>GYSPOT EXPERT 200</b>	200-240V	8 m	4350 > 5100	7,2-8,7	30(D)	3100 > 3600	25 > 36	OK	OK	■	■	■	■	■	■	■	■	22,5 x 36 x 23,5	24.5
	<b>GYSPOT EXPERT 230</b>	230V	8 m	3800	7,4	16	2800	20	OK	OK	■	■	■	■	■	■	■	■	22,5 x 36 x 23,5	20.5
<b>GYSPOT EXPERT 400</b>	400V, 2ph	8 m	4500	7,4	16(D)	3200	25	OK	OK	■	■	■	■	■	■	■	■	22,5 x 36 x 23,5	22.5	



GYS POT ALU



# DENT PULLING

## ALU

**FV** FLEXIBLE VOLTAGE

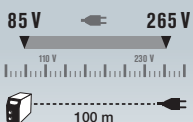

SYNERGIC CONTROL

PATENTS REGISTERED NUMBERS  
EUROPEAN TRADEMARK & DESIGN

Alu



Goujons - Studs

Acier / Steel / Stahl



- ▽ Étoiles - Stars
- ⊗ Anneaux - Rings
- 〰 Filis ondulés - Wavy wires
- ⊔ Rabattage d'impact - Impact shrinking
- ↘ Rétreinte - Tempering
- ⊔ Rivets - Rivets
- ⊙ Rondelles - Rings
- ≡ Goujons - Studs



**FIXED GUN**

GYS POT ALU PRO FV

100 > 230 V • 1 ~

**7500 A**

x1 AUTOMATIC

FV

021990

included

for Ø 4 mm



Automatic alu gun  
3 m, 25 mm<sup>2</sup>



ALU BOX STANDARD (050020)  
(Details p.11)

ALU GUN



AUTOMATIC

3 m, Ø 25 mm<sup>2</sup>

included ALU PRO FV  
& COMBI 230  
E.PRO



(x 3)  
065635

**66 mF** CAPACITOR DISCHARGE WELDING

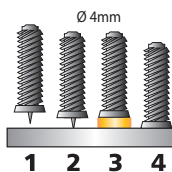

Ø 4mm

1 2 3 4

Joint rings for mandrel Ø 4/5/6  
x 2  
060814

PATENTS REGISTERED NUMBERS  
002446450-0001  
EUROPEAN TRADEMARK & DESIGN

OPTIONS

Consommables - Consumables  
p.10



Accessoires ALU - ALU accessories  
p.19



Chariots - Trolleys  
p.23







# DENT PULLING

ALU + ACIER / STEEL / STAHL

**2 GUNS INCLUDED**



**GUN WITH CONNECTOR**

### GYSPOT COMBI 230 E.PRO

230V • 1~

<b>+</b>	<b>3800 A</b> Acier / Steel / Stahl	<b>T</b> <b>x2</b>	AUTOMATIC
	<b>7500 A</b> Alu		MANUAL
			AUTOMATIC

021266

included

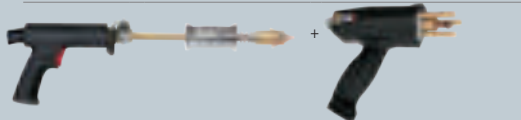

Manual quick gun, 2 m, 70 mm<sup>2</sup> (057524)  
+ Hammer (057272)

Automatic alu gun, 3 m, 25 mm<sup>2</sup>



Earth cable  
2 m, 70 mm<sup>2</sup>

SPOTTER BOX PRO (050075)  
(Details p.10)

ALU BOX STANDARD (050020)  
(Details p.11)

MADE IN FRANCE 62135	50/60 Hz	2 m	I <sub>2</sub> max A	U <sub>2</sub> V	I <sub>AM</sub> A	I <sub>RMS</sub> A	kW	OK	OK	MANUAL	SYNERGIC	AUTOMATIC	MANUAL	SEPARATE CABLE GUN	3 m	Included Alu box	cm	kg		
																			230V	8 m
GYSPOT ALU PRO FV	110 > 230V	2 m	7500	50 > 200	5	—	0.65	OK	OK	■	■	—	■	x1	—	—	3 m	Included Alu box	21 x 24 x 36	12.5
GYSPOT COMBI 230 E.PRO	230V	8 m	3800 (steel) 7500 (alu)	7,4 (steel) 50 > 200 (alu)	16	2800 (steel)	20	OK	OK	—	■	■	■	x1	x1	■	2/3 m	Included Spotter box + Alu box	45 x 43 x 29	42.5



# GYSPOT ACCESSORIES & CONSUMABLES



## ACIER / STEEL / STAHL

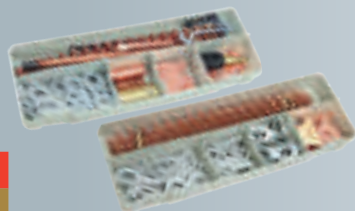

DENT BOX CONSUMABLES / BAR / EASY  
SPOTTER BOX STANDARD / 2600 / 2700



SPOTTER BOX PRO



Étoile - Star -  
Ausbeulstern

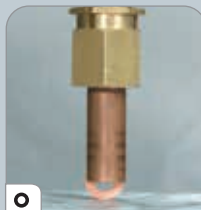

Rondelle - Ring -  
Unterlegscheiben



Rétreinte -  
Tempering -  
Temperieren



Rabattage d'impact & Écrou -  
Impact shrinking & Lock nut -  
Glätten

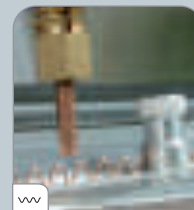

Fil ondulé - Wavy wire -  
Wellendraht

hexagon	Earth plate small	chuck for inertia hammer	copper coating star	electrode ø 16 for 8 x 16	ø 8 x 16	earth hook	carbon heating electrode	electrode warming point ø 16	Ball electrode warming point Ø16	M8	electrode	wavy wire	magnetic positioner
		x1	x20	x1	x100	x1	x5	x1	x1	x100	x1	x50	x1
		049482	052239	049574	049444	056718	049468	049567	059726	050303	049789	049727	049772

### DENT BOX

**CONSUMABLES**  
051515

x20

x25

**BAR**  
050037



x1

x25

**EASY**  
053632



x1

x1

x1

x20

x1

x50

x1

x1

x1

x1

x25

### SPOTTER BOX

**PRO**  
050075



x1

x1

x1

x20

x1

x50

x1

x1

x1

**STANDARD**  
053915

x1

x1

x1

x20

x1

x50

x1

x1

x1

**2600**  
052277



x20

x1

x50

x1

**2700**  
053922



x20

x1

x50

x1

x1

**Affuteur d'anneaux acier - Steel Ring sharpener**  
072565

**NEW**



Acier - Steel - Stahl

Poinçon et matrice affuteur pneumatique pour anneaux acier - Pneumatic punch and die sharpener for steel rings  
072299

**Mandrins pour pistolets - Mandrels for gun - Pistole & Anschlußstücke, Zubehör**

Pour débosseurs - for dent pullers - Anschlußstück für Ausbeulspotter-Pistole

**QUICK GUN**  
057531



**D1**  
048959



**S1 < nov 2010**  
048171



**S2 > nov 2010**  
048188



Écrou - Nut  
053199



Microswitch  
053267







<b>Anneaux - Rings - Zugösen</b>	<b>Goujons - Studs - Gewindebolzen</b>	<b>Rivets - Rivets - Nieten</b>	<b>Clous - Nails</b>	<b>Molette - Stitch welding</b> <i>for spot welding machine only</i>	
 electrode x1 050655  straight rings x100 050648  twisted rings x50 050631  lifting rod x3 180, 300, 500 mm 050792	 electrode for threaded studs rivets ø 5 - M5, M6 x1 049598  threaded M5 x 18 x 0.8 x100 049383  self-threading ø 5 x 18 x100 049420  self-threading ø 5 x 12 x100 049413	 electrode ø 16, 3 x 4,50 x1 049604  ø 3 x 3,25 x100 049345  ø 3 x 4,50 x100 049352	 electrode ø2 - M4 x1 049277  ø2 x100 041561	 electrode wheel ø16 x1 050310  flat n°27 x1 049673  Earth plate large x1 052529  magnetic x1 049666	

--	--	--	--	--	--	--	--	--	--	--	--

	ELECTRODE FOR MAGNETIC EARTH (x1) 050013
	THREADED ROD FOR MAGNETIC EARTH (x5) 055438
	SINGLE HOOK (x1) 051218

## ALU

Joint rings for mandrel ø 4/5/6  
x2  
060814

<b>mandrel for ALU GUN</b>	<b>alu magnesium screws 12 mm</b>	<b>alu silicium screws 12 mm</b>	<b>screwable rings</b>	<b>fast pulling rings</b>	<b>lifting rod</b>
 ø 4 x2 049000  ø 5 x1 048157  ø 6 x1 048164	 ø 4 - M4 x200 050273  ø 4 - M4 x1000 050129  ø 5 x100 048140  ø 6 x100 048133	 ø 4 - M4 x200 050280  ø 4 - M4 x1000 050136  ø 5 x100 048126  ø 6 x100 048003	 ø 4 x5 050297  ø 5 x5 058712	 x3: 180, 300, 500 mm 050792	

ALU BOX LIGHT ø 4 / STANDARD ø 4 / ø 5 & 6

<b>ALU BOX</b>					
<b>LIGHT ø 4</b> 051522		ø 4 x200	ø 4 x200		
<b>STANDARD ø 4</b> 050020 <small>included GYSTOT ALU &amp; COMBI 230</small>		ø 4 x200	ø 4 x200	x5	x1
<b>ø 5 &amp; 6</b> 048195	x1 x1	ø 5 x100 + ø 6 x100	ø 5 x100 + ø 6 x100	x5	



GYSPOT ARC PULL

# DRAWN ARC

## DENT PULLING

ALU + ACIER / STEEL / STAHL







SYNERGIC

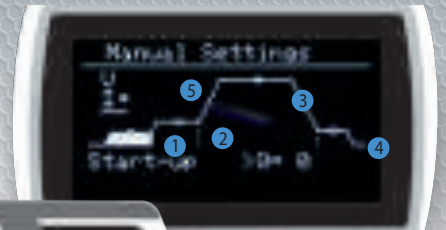

MANUAL

EXPERT Control



-  Anneaux - Rings - Zugösen
-  Goujons - Studs - Gewindebolzen
-  Tiges inox - Stainless steel nails - Edelstahlnägel



- 1 Amorçage - Start-up - Zündung
- 2 Décapage - Scouring (l & t) - Abbeizen
- 3 Arc (l & t) - Arc - Lichtbogen
- 4 Accroche - Hitching (l & t) - Verklebung
- 5 Hauteur - Height - Höhe

**7**  
languages  
FR, EN, DE, SP, IT,  
NL & RU

### SYNERGIC DIGITAL GUNS



**UNIQUE**  
**Linear Motor**

**DRAWN ARC PROCESS**  
Gas protection

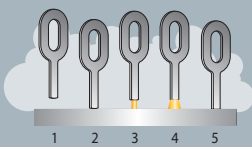

3 m, Ø 25 mm<sup>2</sup>

included  
ARC PULL  
200 & 350,  
COMBI ARCPULL



Full control



Consumables for Gun



x2  
059627

x1  
059610

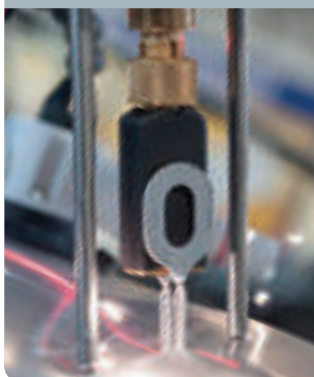

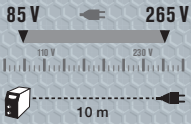
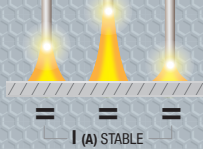
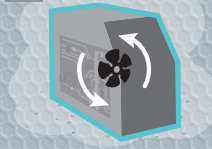

**FV FLEXIBLE VOLTAGE**

**SR SECONDARY REGULATION**

**AD ANTI-DUST**

**MANUAL & SYNERGIC CONTROL**
**NEW**
**2 GUNS INCLUDED**

 Ø max  
 Alu : 6 mm  
 Fe : 6 mm

**GUN WITH CONNECTOR**
**GYSPOT ARC PULL 200**

100 · 230V · 1~

**200 A** x1 MANUAL

**FV SR AD**

057470

included

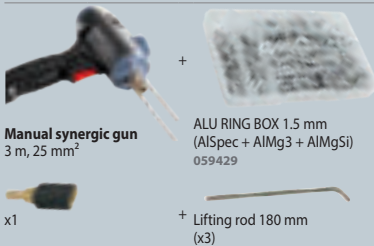
**COMBI ARCPULL**

230V · 1~

**ARCPULL**
**200 A**

Alu

**MANUAL**

069824

Arcpull accessories included

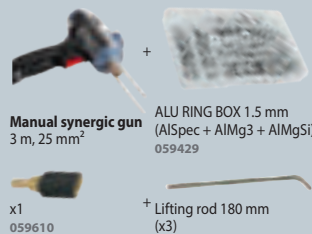
**EXPERT**
**3800 A**

Acier / Steel / Stahl

**MANUAL**
**OPTION : AUTOMATIC**

Expert accessories included

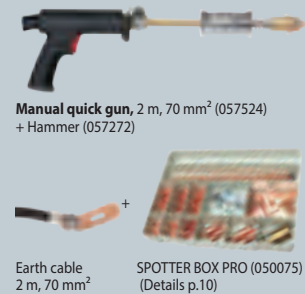

MADE IN FRANCE CE NORX 60974-1	50/60 Hz	6 m	I <sub>2</sub> A	SYNERGIC	MANUAL	IRMS (A)			U <sub>2</sub> V	A	kW	OK	OK	cm	Product	Product + gun
							Acier/Steel	Alu								
<b>GYSPOT ARC PULL 200</b>																
110 · 230V    6 m    10 · 100 (110 V) 10 · 200 (230 V)    ■    ■    —    Manual + Digital Gun Motion Control    20.4 · 24 V (110 V) 20.4 · 28 V (230 V)    16    2.4 (110 V) 5.6 (230 V)    OK    OK    20.5 x 25 x 33    8.6 kg    11.9 kg																
<b>COMBI ARCPULL</b>																
230V    8 m    Alu 10 · 200    ■    ■    Steel 3800    Manual    Manual    Alu 20.4 · 28 V    16    Alu 5.6    OK    OK    45 x 37 x 24.5    29 kg    39 kg Acier 3800    Automatic (not included)    Steel 7.4 V    Steel 20																



GYSPOT ARC PULL

# DRAWN ARC DENT PULLING



ALU + ACIER / STEEL / STAHL

SYNERGIC



EXPERT Control

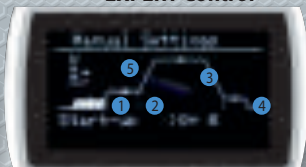

- 🔑 Anneaux - Rings - Zugösen
- 🔩 Goujons - Studs - Gewindebolzen
- 🔩 Tiges inox - Stainless steel nails - Edelstahlnägel

- 1 Amorce - Start-up - Zündung
- 2 Décapage - Scouring (l & t) - Abbeizen
- 3 Arc (l & t) - Arc - Lichtbogen
- 4 Accroche - Hitching (l & t) - Verklebung
- 5 Hauteur - Height - Höhe

MANUAL



7 languages  
FR, EN, DE, SP, IT, NL & RU

## SPECIAL TEARING RIVETS

Spécial arrachage de rivets - Spezial-Zugnieten

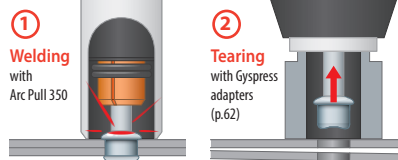

∅ max  
Alu/Fe :  
8 mm

## SYNERGIC DIGITAL GUNS

★★★★★  
**UNIQUE  
Linear  
Motor**

**DRAWN ARC PROCESS**  
Gas protection

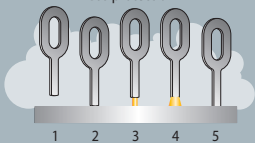

FULL CONTROL

3 m, ∅ 25 mm<sup>2</sup>

included  
ARC PULL  
200 & 350,  
COMBI ARCPULL



Consumables for Gun



GYSPOT ARC PULL 350

208 - 240 V • 1 ~

**350 A**

🔧 x1 MANUAL

PFC SR AD

062191

included



Manual synergic gun  
3 m, 25 mm<sup>2</sup>

PACKS ARC PULL 350	Arc Pull 350	Croco T400.70 043787	Rivet box 064584	Alu ring box 1.5 mm 059429	059610	Lifting rods 050792
<b>350 RIVET</b> 064645	■	■	■	—	—	—
<b>350 PULLER</b> 064652	■	—	—	■	x1	180, 300, 500 mm
<b>350 PULLER + RIVET</b> 064669	■	■	■	■	x1	180, 300, 500 mm

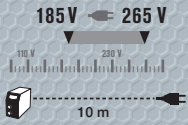
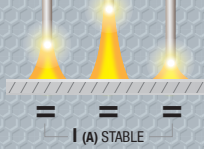
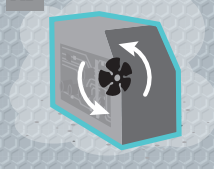

**PFC POWER FACTOR CORRECTION**

**SR SECONDARY REGULATION**

**AD ANTI-DUST**

∅ max  
Alu: **10 mm**  
Fe: **13 mm**

**NEW**
**PRO**  
★★★

**GYSPOT ARC PULL 700**

380 › 480V • 3~

**680 A**

x1 MANUAL

**SR** IP 23

**OPTIONS**

details p.23

 Weld 810 for ARC PULL 200 & 350  
037489

 Weld 910 for ARC PULL 700  
070967

**068315**

included

- Manual synergic gun**  
3 m, 50 mm<sup>2</sup> +
- Double earth clamps**  
700 A, 3 m, 50 mm<sup>2</sup>  
068605
- Arc Pull Rivet Box 700** +
- ALU RING BOX**  
1.5 mm (AlSpec + AlMg3 + AlMgSi)  
059429
- Lifting rod 180 mm**  
(x1) +
- Gas protection**  
(x1)  
068346
- Ground studs holder**  
∅ 6 (x1) 075368  
∅ 8 (x1) 075375  
∅ 10 (x1) 075382
- Threaded holder**  
∅ 5 (x1) 076174  
∅ 6 (x1) 068391



 MADE IN FRANCE 60974-1	 50/60 Hz	 6 m	I <sub>2</sub> A	SYNER-GIC			TECHNOLOGY		U <sub>2</sub> V	 A	kW	 OK	 OK	 cm	 ArcPull	 kg
					Acier/Steel	Alu	Power Factor Correction	Flexible Voltage								
<b>GYSPOT ARC PULL 350</b>	208 › 240V	6 m	10 › 350	■	Manual + Digital Gun Motion Control		■	—	20.4 › 34 V	16	11.9	OK	OK	23 x 31 x 28.4	11 kg	14.3 kg
	3x 400V															
<b>GYSPOT ARC PULL 700</b>	3x 480V	5 m	50 › 680	■	Manual + Digital Gun Motion Control		—	—	22 › 44 V	20 A (D)	47.8 kW	OK	OK	32 x 32.4 x 41	17.4 kg	20.4 kg
	3x 480V				16 A (D)	45.7 kW										



# GYSPOT ARC PULL 200, 350 & COMBI ACCESSORIES & CONSUMABLES



## ACIER / STEEL / STAHL

											self-threading studs M5								
	x1	x1	x1	x100	x100	x2	x100	x100	x1	x100	x100	x100	x1	x100	x200	x1	x200	x1	x100
<b>STEEL STUDS BOX 200 &amp; 350</b> 059443	x1	x1					x1	x100	x1	x100	x100	x100							

## ALU

	x1	x1	x2	x100	x1	x100	x1	x100	x200	x1	x200	x1	x100
<b>ALU STUDS BOX 200 &amp; 350</b> 059436	x1	x1	x1	x100	x1	x100	x1	x100					

	straight rings				twisted rings								
	Al-Special		AIMg3		AIMgSi		Al-Special		AIMg3 - x 50		AIMgSi - x 50		
	n°1 1mm	n°4 1.5mm	n°8 2mm	n°2 1mm	n°5 1.5mm	n°3 1mm	n°6 1.5mm	n°1 1mm	n°4 1.5mm	n°2 1mm	n°5 1.5mm	n°3 1mm	n°6 1.5mm
	x100	x100	x100	x100	x100	x100	x100	x50	x50	x50	x50	x50	x50
	059535	059559	065703	059498	059511	059450	059474	059542	059566	059504	059528	059467	059481
box	<b>ALU RING BOX 1 mm</b> 059412			1mm x50		1mm x50		1mm x20		1mm x20		1mm x20	
box	<b>ALU RING BOX 1.5 mm</b> 059429			1.5mm x50		1.5mm x50		1.5mm x20		1.5mm x20		1.5mm x20	
sachet - bag	<b>ALU RING BOX 2 mm</b> 065703			2mm x100									

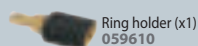
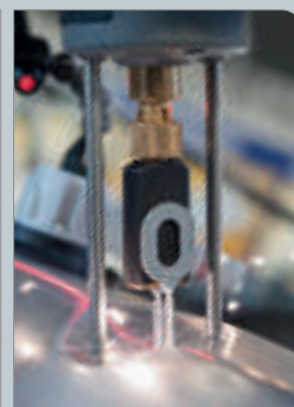

Ring holder (x1)  
059610



Tension mandrel for M4 (x1)  
050327



Earth clamp  
Croco T400.70  
043787



Double earth clamp  
25 mm²; 3 m, 350 A  
070714

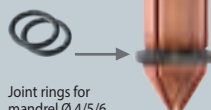

Joint rings for  
mandrel Ø 4/5/6  
x2  
060814



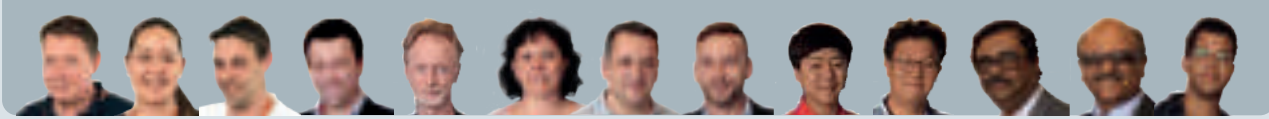

<p>STUDS HOLDER BOX 350</p> <p>DIFFICULT ACCESS BOX 350</p>	<p>Support porte-goujon - Mandrel support x1 059634</p>	<p>Buse + patin - Nozzle + pad x1 059641</p>	<p>Ø2mm x1 064065</p>	<p>Ø4mm x2 049000</p>	<p>Ø5mm x1 048157</p>	<p>Ø6mm x1 048164</p>	<p>Ø7.1mm x1 064041</p>	<p>Ø8mm x1 064058</p>	<p>Canon long - Long barrel Ouvert - Opened x1 070806</p>	<p>Fermé - Closed x1 070790</p>	<p>Mandrin long - Long mandrel M4 x1 070752</p>	<p>M5 x1 070769</p>	<p>M6 x1 070776</p>	<p>M8 x1 070783</p>	<p>25 mm<sup>2</sup>, 3 m, 350 A x1 070714</p>
<p><b>ARC PULL DIFFICULT ACCESS BOX 350</b> 070813</p>	x1	x1							x1	x1	x1	x1	x1	x1	x1

Difficult access :

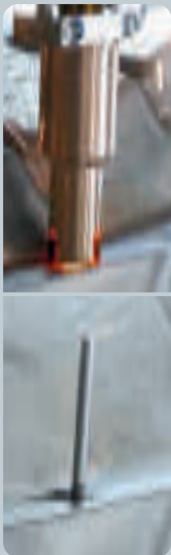
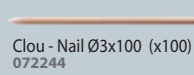
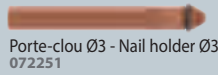

<p>ARC PULL RIVET BOX 1 350 - 24kN 064584</p>	<p>Tige inox Stainless steel nail Ø 4 x 50 mm x 100 064607</p>	<p>Canon pour pose de tige inox - Barrel for stainless steel nail welding -</p>	<p>Support porte-goujon - Mandrel support x1 059634</p>	<p>Buse + patin - Nozzle + pad x1 059641</p>	<p>mandrel Ø4mm x2 049000</p>	<p>Buse d'extraction 24kN Ø4 x1 064683</p>	<p>Canon long + mandrin M4 + mandrin M5 x1 067721</p>	<p>Tige inox Stainless steel nail Ø 5 x 50 mm x 100 070745</p>	<p>Buse d'extraction 50kN Ø 5 x1 066151</p>
<p><b>ARC PULL RIVET BOX 2 350 - 50 kN</b> 073388</p>			x1	x1			x1	x100	x1

Extraction with GYSPRESS & adapters

details p.68

GYPRESS + adapter 24kN for Ø 4

GYPRESS + adapter 50kN for Ø 4 & 5

GYSPOT ARC PULL 700 - ACCESSORIES & CONSUMABLES



<p>ARC PULL RIVET BOX 700 068452</p>	<p>Tige inox - Stainless steel nail Ø 5 x 50 mm x 100 070745</p>	<p>Canon long + mandrin M5 - Long barrel + mandrel M5 x1 070738</p>	<p>Buse d'extraction 50 Kn Ø 5 x1 066151</p>	<p>Support porte-goujon - Mandrel support x1 071377</p>	<p>Buse + patin - Nozzle + pad x1 059641</p>	<p>Ring holder x1 059610</p>	<p>Fourche pour anneau - Rod for pulling rings x1 071384</p>	<p>Vis de butée x1</p>

Gas protection (x1)  
068346

Ground studs holder  
Ø 6 (x1)  
075368  
Ø 8 (x1)  
075375  
Ø 10 (x1)  
075382

Threaded holder  
Ø 5 (x1)  
076174  
Ø 6 (x1)  
068391

Double earth clamp  
50 mm<sup>2</sup>, 3 m, 700 A  
068605



# FAST DENT PULLING



## ACIER / STEEL / STAHL

### EASY TOOL CONNECTION



for GYSPT  
39.02/04,  
PRO 230/400,  
EXPERT 200/230/400,  
COMBI 230 PRO

051690



3 m  
Ø 35 mm<sup>2</sup>

Masse pistolet acier  
- Steel gun earth adapter  
- Masse für Stahl Pistole

051997

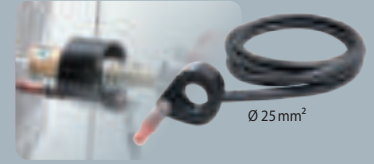

Ø 25 mm<sup>2</sup>

051584

380 g



Anneaux  
- Rings  
- Anschweißösen

051652



Fils ondulés  
- Wavy wires  
- Wellendraht

051669

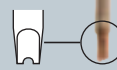

Rétreinte  
- Tempering  
- Glättwerkzeug

051676



EASYGUN  
051317

Box of 3  
electrodes for  
accessories  
050822

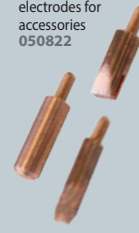

Poignée  
de tirage  
manuel  
057289



### MANUSPOT = 050679



Tools set & support  
for DENT 600, 800, 1000, 1600,  
Workstation & Dentstation

+ EASYGUN  
051317



MANLINER  
050471



PATENTS REGISTERED NUMBERS  
001652108-0003  
EUROPEAN TRADEMARK & DESIGN

3 m  
Ø 35 mm<sup>2</sup>

### MANLINER/GUN 056831

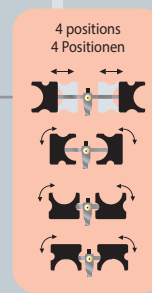

4 positions  
4 Positionen

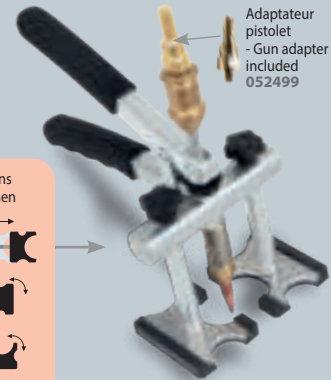

Adaptateur  
pistolet  
- Gun adapter  
included  
052499



PATENTS REGISTERED NUMBERS  
001652108-0003  
EUROPEAN TRADEMARK & DESIGN

Direct impact electrodes (x5)  
050839

Patins - Pads (x2)  
060807

### FAST & EASY



### RINGMATIC 052154

included  
(x 50)



Option  
Adaptateur  
pistolet - Gun  
adapter  
052499

### AFFUTEUR D'ANNEAUX ACIER - Steel Ring sharpener - Stahl Zugöseschneider

072565

Acier -  
Steel -  
Stahl



Poinçon et matrice affuteur  
pneumatique pour anneaux  
acier - Pneumatic punch and  
die sharpener for steel rings  
072299

### QUICK SPOT AIR GUN V2

057340

LIGHT  
920 g



2,5 m

AIR

### QUICK SPOT AIR GUN V2 + Mini-fraiseuse - Mini- Druckluftfräser

065567

057340 + 063228



Included  
Tungsten drill  
Ø 6 mm  
054172

Adaptateur pistolet - Gun adapter  
052826







### ALU ARC PULLER PREMIUM

065161

Included Alu 3 065178

Included Alu 4 065185

Patins - Pads (x2) 069008

### ARC PULLER PREMIUM PRO

072572

Patins - Pads (x4) 074958

Included Alu 3 065178

Included Alu 4 065185

**ULTRA RESISTANT**  
No deformation

GRIP

Full rotation

Multi positions

### ALU PULLER

051003

4 positions

Included Alu 1 050938

Included Alu 2 050945

Patins - Pads (x2) 060807

### LAMPE LIGNE DROITE

- Straight line lamp - Dentline-laser

056770

### ANNEAUX DE TIRAGE RAPIDE

- Fast pulling rings

058743

x5 058712

goujons alu - alu screws ø 4, 5 & 6 mm

Alu 1 050938

Alu 2 050945

Marteau à inertie 380 g 050051

### MARTEAUX ALU

- Alu hammers

020986

<p>Décapeur thermique - Heat gun - Heißluftpistole</p> <p>I : 100/300°C (450 W) II : 300/650°C (1500 W) Air flow : 450 l/min</p> <p>Affichage digital Digital display</p> <p>066311</p>	<p>Pistolet à air chaud autonome à gaz - Gas hot air gun</p> <p>Bouteille de gaz incluse, gas cylinder included</p> <p>060777</p>	<p>Lampe à souder - Blow torch - Lötlampe</p> <p>052741</p>	<p>Novacet + (Butane/propane/ propylene) 380ml/220g</p> <p>HIGH QUALITY</p> <p>040441</p>	<p>Brosses - Brushes - Bürsten - Brossen - Cepillos</p> <p>Inox - Stainless - Edelstahl</p> <p>044258</p>	<p>Crayon marqueur thermique - Thermal marking pencil</p> <p>121°C / 250°F</p> <p>052765</p>	<p>Thermomètre infrarouge - Infrared Thermometer</p> <p>-50 / +380°C -58 / +716°F</p> <p>052994</p>	<p>Spray refroidisseur - Freezer spray</p> <p>-50 °C 400 ml</p> <p>(x 12) 048898</p>	<p>Spray barrière thermique - Heat barrier spray</p> <p>054325</p>
---	---	---	---	---	--	---	--	--

## MARTEAUX INERTIE - Slide hammers - Ausbeulhammer

### COMPLETE 057272

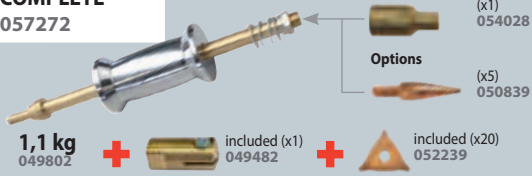

1,1 kg  
049802

### Clous - Nails - Nägel



1,1 kg  
041813

### Rondelles - Washers - Ringe



1,7 kg  
051201

### COMPLETE KIT 051225

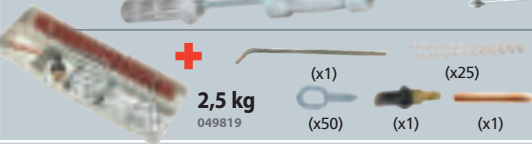

### Kit marteau à inertie - Inertia hammer kit - Ausbeulhammerset



### Poignée de tirage 3 dents - Pulling handle 3 claws - Handzugkralle 3-fach

057326



### Poignée de tirage 2 dents - Pulling handle 2 claws - Handzugkralle 2-fach

057319



### Alu Puller 051003

050921



### Alu 1 050938

Alu 2 050945



## STANDARD

### Levier de débosselage - Levelling lever - Zughebel

1.6 kg

050686

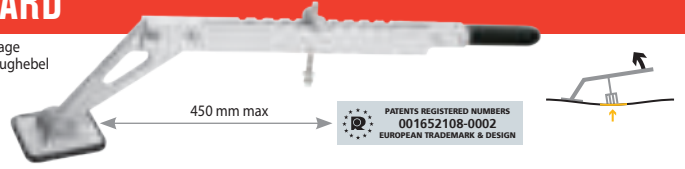

### Barre de débosselage double action - Double action levelling bar - Zughebelbrücke

053564

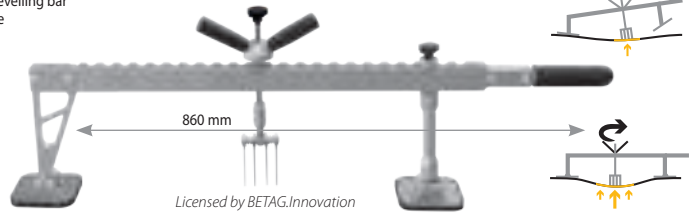

### Barre de débosselage - Levelling bar - Zugbrücke

3.4 kg

050693

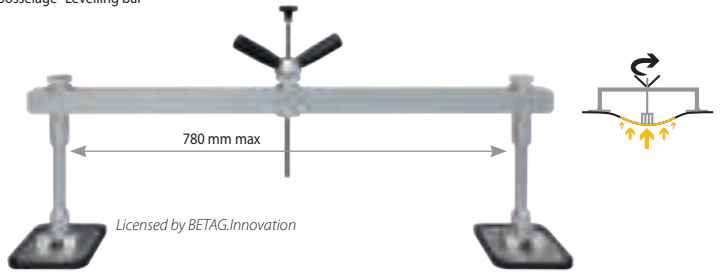

### Barre de tirage renforcée - Reinforced scissoring bar - Scherenzugbrücke

5.1 kg

050716

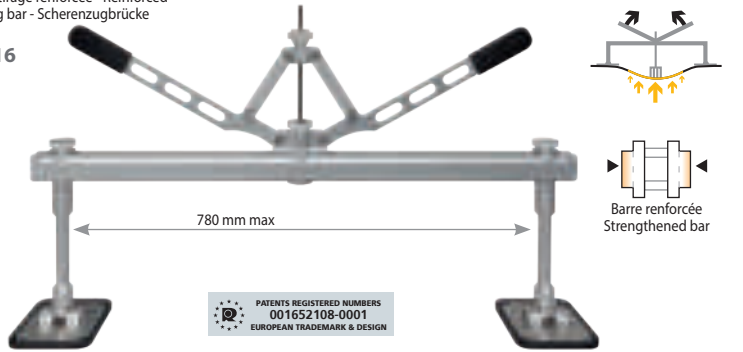

## OPTIONS

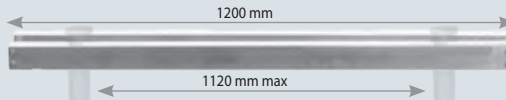

### Barre renforcée - Reinforced bar - 1200 mm 051171

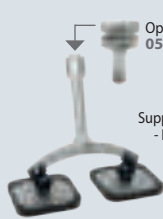

### Support double patin - Double pads support - DoppelfüÙe 050723



## GRIFFES - Gripping hook head - Ausbeulhaken

Curved lifting rod 280 mm 064706

Lifting rods 180, 300 & 500 mm 050792

Compatibility:

STANDARD

PREMIUM

STANDARD

PREMIUM

Long feet needed

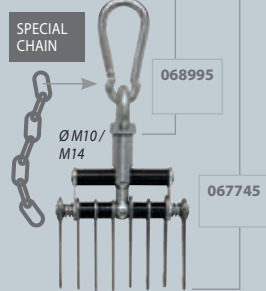
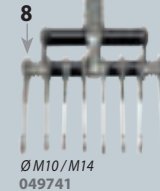
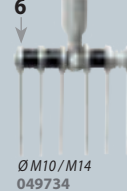
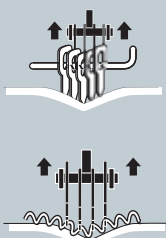



**PREMIUM**

**ULTRA LIGHT**

**ULTRA ERGONOMIC**

**ULTRA RESISTANT**  
No deformation

**PERFECT BALANCE**



21  
**LEVELLING BARS**

**DENT PULLING**

Levier de débosselage Premium  
- Premium Levelling lever  
- Premium Zughebel  
**1.6 kg**  
**059290**

2 positions

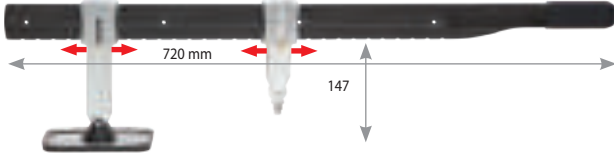

Barre de débosselage Premium  
- Premium levelling bar  
- Premium Zugbrücke  
**2.8 kg**  
**059306**

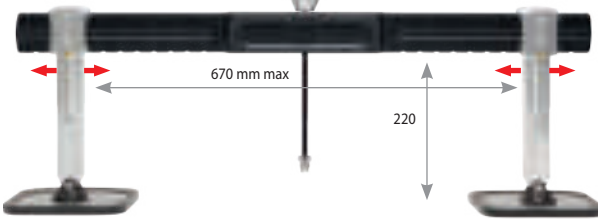
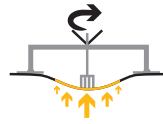

Multi positions



Arc Puller Premium  
065161



Barre de tirage Premium  
- Premium scissoring bar  
- Premium Scherenzugbrücke  
**3.1 kg**  
**058996**

Old design

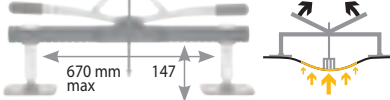

Barre de tirage 1200 renforcée Premium  
- Premium 1200 scissoring bar  
- Premium Scherenzugbrücke 1200  
**5.6 kg**  
**059313**

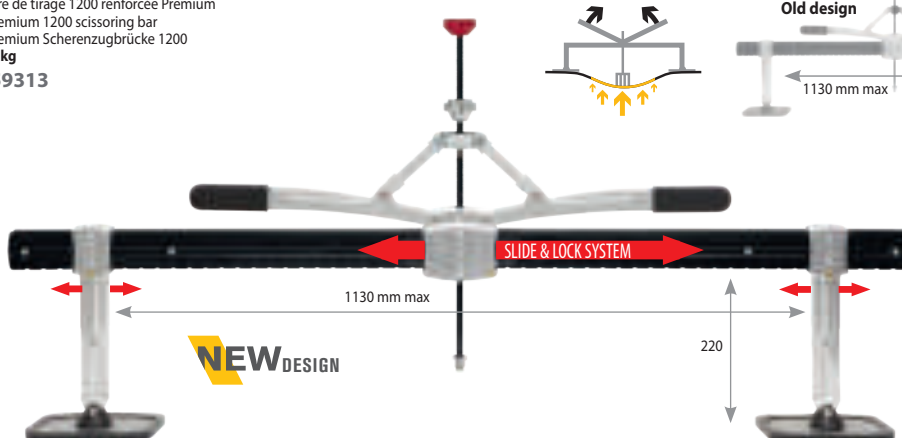
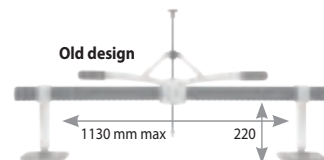
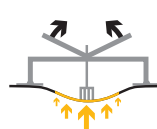

Strengthened bar  
Barre renforcée

# PREMIUM PRO

Barre de débosselage Premium Pro 900 mm  
 - Premium Pro levelling bar 900 mm  
 - Premium Pro Zugbrücke 900 mm  
**3.8 kg**  
**071643**

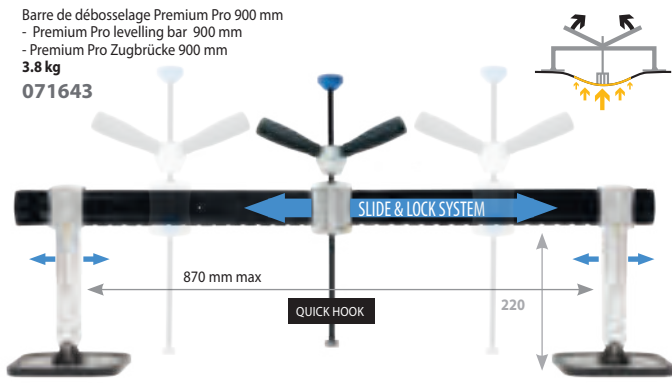

Barre de tirage Premium Pro 900 mm  
 - Premium Pro scissoring bar 900 mm  
 - Premium Pro Scherenzugbrücke 900 mm  
**4.5 kg**  
**072305**

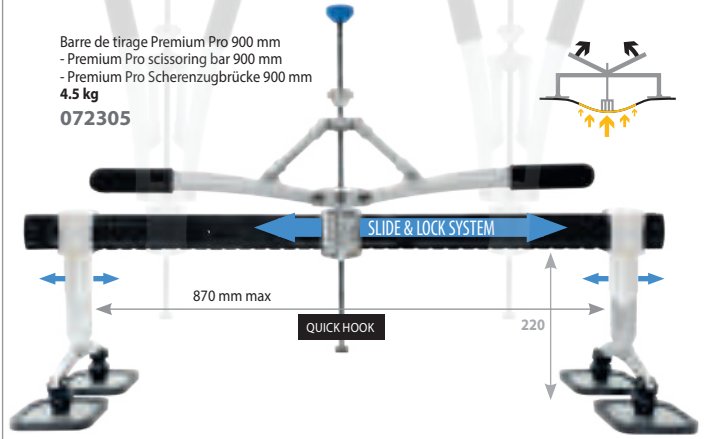

Levier de débosselage Premium Pro  
 - Premium Pro Levelling lever  
 - Premium Pro Zughebel  
**1.6 kg**  
**072619**

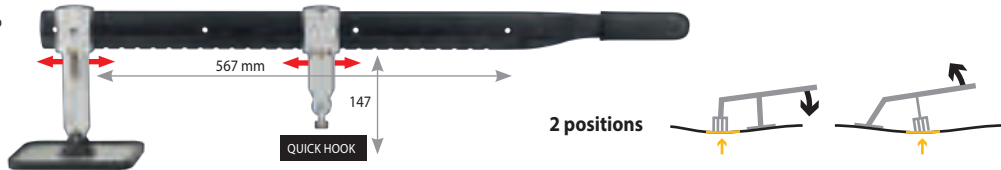

Barre Premium Pro 1150 mm  
 - Premium Pro bar 1150 mm  
 - Premium Pro Scherenzugbrücke 1150 mm  
**072626**



## OPTIONS

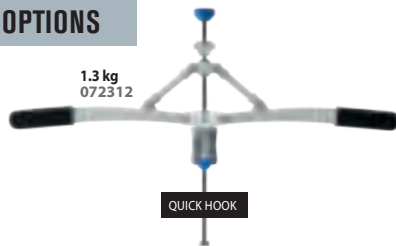

**PREMIUM**  
**QUICK HOOK**

Premium Pro 2-teeth hook



Premium Pro 3-teeth hook



**PREMIUM**  
**QUICK HOOK**

4 072640



6 072657



Arc Puller  
 Premium PRO  
**072572**

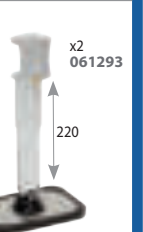
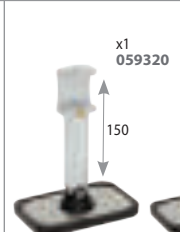
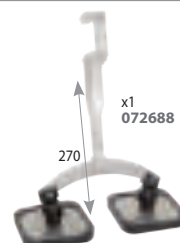
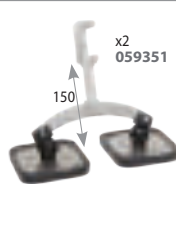

## PREMIUM BAR SMARTHAND

Premium Bar  
 SmartHand  
 for Premium &  
 Premium Pro  
**072480**

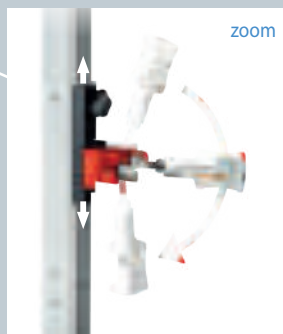
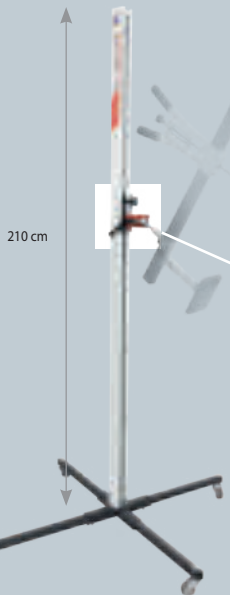





# DENT PULLING WORKSTATIONS

## CHARIOTS / TROLLEYS

Spot 600

39 x 14 x 60 cm,  
7.1 kg  
053533



**NEW DESIGN**  
COMING SOON

Dent 600  
072831

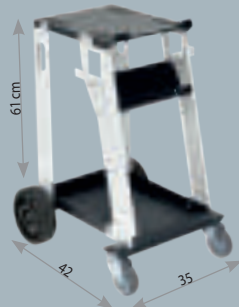

Spot 1000

39 x 14 x 60 cm,  
10.8 kg  
053540

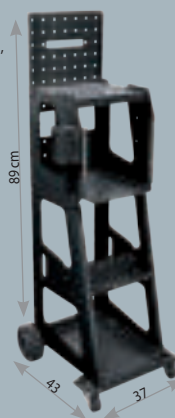

**NEW DESIGN**  
COMING SOON

Dent 1000  
072848

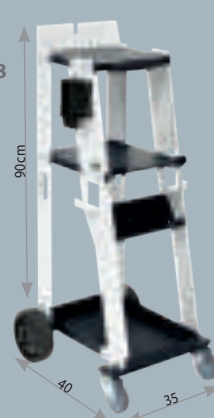

Universal 800

52 x 15 x 80 cm,  
18.1 kg  
051331

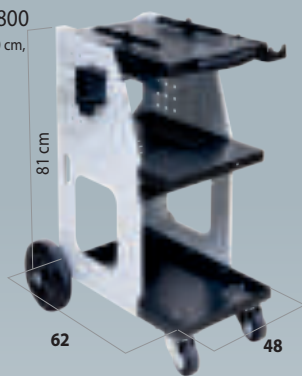

Weld 810

55 x 22 x 78 cm,  
21.6 kg  
037489

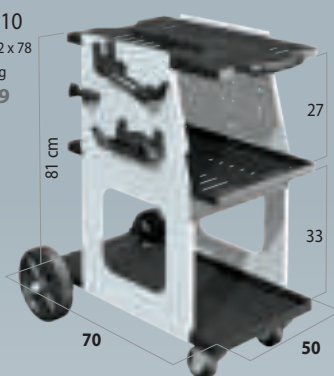

Weld 910

79 x 50 x 115 cm,  
27.5 kg  
070967

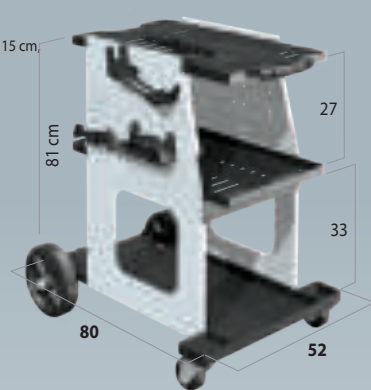

**NEW**

Dent 1600  
072596

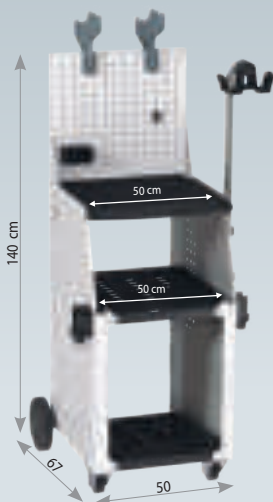

Dent 1600 WD  
072169

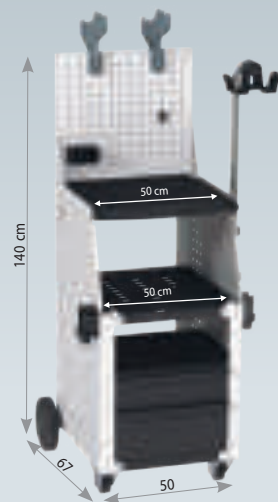

Dentstation PRO  
81 x 29 x 61 cm, 58 kg  
056848

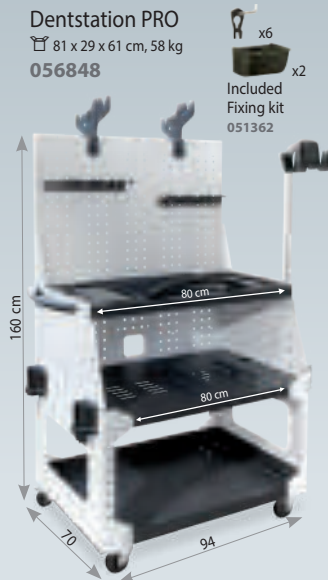

x6  
x2  
Included  
Fixing kit  
051362

**NEW**

Dentstation  
Pro WD  
072800

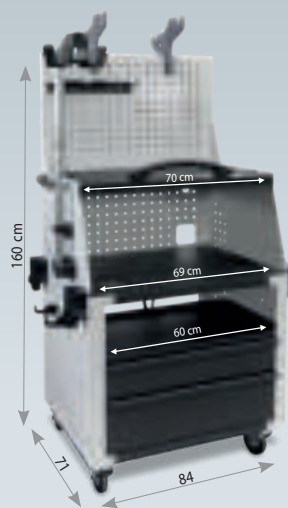

### Compatibility

SPOT	Spot 600	Dent 600	Spot 1000	Dent 1000	Weld 810	Weld 910	Universal 800	Dent 1600	Dent 1600 WD	Dentstation Pro	Dentstation Pro WD
2600, 2700	.	.	.	.	.	.	.	.	.	.	.
34.02/04	.	.	.	.	.	.	.	.	.	.	.
3902/04	.	.	.	.	.	.	.	.	.	.	.
PRO 230/400	.	.	.	.	.	.	.	.	.	.	.
EXPERT 230/400	.	.	.	.	.	.	.	.	.	.	.
ALU PRO FV	.	.	.	.	.	.	.	.	.	.	.
COMBI 230 E.PRO	.	.	.	.	.	.	.	.	.	.	.
ARCPULL 200/350	.	.	.	.	.	.	.	.	.	.	.
ARCPULL 700	.	.	.	.	.	.	.	.	.	.	.



4 m<sup>3</sup> support  
for Spot 1600 &  
Dentstation Pro  
059665

Cable support for  
Spot 800, 1600  
& Dentstation  
052284



Housse de  
protection  
- Protection cover  
- Schutzhaube  
for Universal 800  
062733

for Spot 1600 &  
Dent 1600  
048881

for Dentstation Pro  
059870



# DENT PULLING WORKSTATIONS

UNE SOLUTION COMPLÈTE  
A COMPLETE SOLUTION  
KOMPLETTLÖSUNGEN



✓ PRO 230 072398

EASYLINER ACIER / STEEL / STAHL

## EASYLINER ACIER / STEEL / STAHL

			<b>ALL IN 1 BOX</b>
GYSPOT (guns & consumables included)	DENT 1000 072848	Levelling bar double action 053564 + Dent box easy 053632	
<b>39.02</b> 053618 058521	GYSPOT 39.02		✓
<b>PRO 230</b> 072398	GYSPOT PRO 230		✓

## PROLINER ALU

GYSPOT (guns & consumables included)	UNIVERSAL 800 051331	Cable support 052284	Alu puller 051003
<b>ALU PRO FV</b> 035836	GYSPOT ALU PRO FV	✓	✓
		✓	✓

## PROLINER ACIER / STEEL / STAHL

GYSPOT (guns & consumables included)	UNIVERSAL 800 051331	Cable support 052284	Levelling bar double action 053564 + Dent box bar 050037
<b>39.02</b> 035775	GYSPOT 39.02		✓
<b>39.04</b> 035782	GYSPOT 39.04		✓
<b>PRO 230</b> 035799	GYSPOT PRO 230		✓
<b>PRO 400</b> 035805	GYSPOT PRO 400		✓

## PROLINER ALU (ACIER / STEEL / STAHL)

GYSPOT (guns & consumables included)	Weld 810 037489	Cable support 052284	Arc puller premium 065161
<b>ARC PULL 200</b> 065260	GYSPOT ARC PULL 200	✓	✓
		✓	✓





✓ PRO 230 035799  
✓ PRO 400



✓ 39.02  
✓ 39.04 035782

**PROLINER** ACIER / STEEL / STAHL



✓ ALU PRO FV 035836

























**PROLINER** ALU









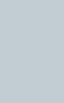















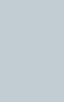

✓ ARC PULL 200 065260

**ALU** (ACIER / STEEL / STAHL)

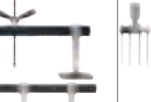
## SPEEDLINER V2

 GYSPT (guns & consumables included)		 DENT 1600 072596	 Cable support 052284	 Levelling bar 050693	 Multihook heads 049758	 Alu Box Ø5 & 6 048195	 Alu puller 051003	 Alu hammers 020986	 Set of pencil punches with 6 teflon tips 052888	 Stainless stell brush 044258	 Hot air gun 650°C 066311	 Infrared Thermometer 052994		
<b>ALU PRO FV</b> 074552	GYSPT ALU PRO FV												✓	
 GYSPT (guns & consumables included)		 DENT 1600 072596	 Cable support 052284	 Manuspot 050679	 Levelling bar 050693	 Levelling lever 050686	 Multihook heads 049758+049734	 3 lifting rods 050792	 Dent box consumables 051515	 Magnetic earth 049666	 Ringmatic 052154	 Alu puller 051003	 Arc puller premium 065161	 4 m³ support 059665
<b>39.02</b> 074422	GYSPT 39.02					✓								
<b>39.04</b> 074439	GYSPT 39.04													
<b>PRO 230</b> 074446	GYSPT PRO 230													
<b>PRO 400</b> 074453	GYSPT PRO 400													
<b>EXPERT 200</b> 074460	GYSPT EXPERT 200					✓								
<b>EXPERT 230</b> 074477	GYSPT EXPERT 230												✓	
<b>EXPERT 400</b> 074484	GYSPT EXPERT 400													
<b>COMBI 230EPRO</b> 074491	GYSPT COMBI 230 E.PRO	✓	x2										✓	
<b>ARC PULL 200</b> + <b>PRO 230</b> 074507	GYSPT ARC PULL 200 + PRO 230													
<b>+ PRO 400</b> 074514	GYSPT ARC PULL 200 + PRO 400													
<b>+ EXPERT 200</b> 074521	GYSPT ARC PULL 200 + EXPERT 200	✓	x2										✓	
<b>+ EXPERT 230</b> 074538	GYSPT ARC PULL 200 + EXPERT 230													
<b>+ EXPERT 400</b> 074545	GYSPT ARC PULL 200 + EXPERT 400													
without generator 035058													✓	

## SPEEDLINER PREMIUM V2

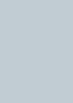
 GYSPT (guns & consumables included)		 DENT 1600 WD 072169	 Cable support 052284	 Premium levelling bar 059306	 Hook head 059382	 3 lifting rods 050792	 Alu Ring Box 1 mm 059412	 Arc puller premium 065161	 Alu hammers 020986	 Set of pencil punches with 6 teflon tips 052888	 Infrared Thermometer 052994	 4 m³ support 059665	 Stainless stell brush 044258	 Hot air gun 650°C 066311	 Alu Ring Box 1,5 mm 059429	 Ring holder 059610	
<b>ARC PULL 200</b> 073999	GYSPT ARC PULL 200							✓									
<b>ARC PULL 350</b> 074934	GYSPT ARC PULL 350																
 GYSPT (guns & consumables included)		 DENT 1600 WD 072169	 Cable support 052284	 Manuspot 050679	 Ringmatic 052154	 Manual pulling handle 057289	 Premium levelling bar 059306 + Premium levelling lever 059290	 Hook head 049758 + 059658 + 059382	 3 lifting rods 050792	 Dent box consumables 051515	 Magnetic earth 049666	 Fast pulling rings (x5) 058712 + Alu puller 051003	 Arc puller premium 065161	 4 m³ support 059665			
<b>PRO 230</b> 073883	GYSPT PRO 230																
<b>PRO 400</b> 073890	GYSPT PRO 400																
<b>EXPERT 200</b> 073906	GYSPT EXPERT 200																
<b>EXPERT 230</b> 073920	GYSPT EXPERT 230																
<b>EXPERT 400</b> 073944	GYSPT EXPERT 400																
<b>COMBI 230EPRO</b> 073968	GYSPT COMBI 230 E.PRO	✓	x2														
<b>COMBI ARCPULL</b> 074569	GYSPT COMBI ARCPULL																
<b>ARC PULL 200</b> + <b>PRO 230</b> 073975	GYSPT ARC PULL 200 + PRO 230																
<b>+ PRO 400</b> 073982	GYSPT ARC PULL 200 + PRO 400																
<b>+ EXPERT 200</b> 073913	GYSPT ARC PULL 200 + EXPERT 200	✓	x2														✓
<b>+ EXPERT 230</b> 073937	GYSPT ARC PULL 200 + EXPERT 230																
<b>+ EXPERT 400</b> 073951	GYSPT ARC PULL 200 + EXPERT 400																





✓ ALU PRO FV 074552

✓ 39.02, 39.04 074477  
 ✓ PRO 230, PRO 400  
 ✓ EXPERT 200, EXPERT 230, EXPERT 400

**SPEEDLINER V2** ALU

ACIER / STEEL / STAHL

**COMPLETE SYSTEM**

★ ★ ★



✓ COMBI 230 E.PRO  
 ✓ ARC PULL 200 + PRO 230  
 ✓ ARC PULL 200 + PRO 400  
 ✓ ARC PULL 200 + EXPERT 200  
 ✓ ARC PULL 200 + EXPERT 230  
 ✓ ARC PULL 200 + EXPERT 400 074538

**SPEEDLINER V2** ALU + ACIER / STEEL / STAHL

**PREMIUM COMPLETE SYSTEM**

★ ★ ★ ★



✓ COMBI 230 E.PRO  
 ✓ COMBI ARC PULL  
 ✓ ARC PULL 200 + PRO 230  
 ✓ ARC PULL 200 + PRO 400  
 ✓ ARC PULL 200 + EXPERT 200  
 ✓ ARC PULL 200 + EXPERT 230  
 ✓ ARC PULL 200 + EXPERT 400 073937

**SPEEDLINER PREMIUM V2** ALU + ACIER / STEEL / STAHL



073999  
 ✓ ARC PULL 200, ARC PULL 350

073920  
 ✓ PRO 230, PRO 400  
 ✓ EXPERT 200, EXPERT 230, EXPERT 400

**SPEEDLINER PREMIUM V2** ALU

ACIER / STEEL / STAHL



## DENTSTATION

GYSPOT (guns & consumables included)	Dentstation Pro 056848 + Fixing kit 051362	Cable support 052284	Manuspot 050679	Ringmatic 052154	Manual pulling handle 057289	Levelling lever 050686 + Levelling bar 050693 + Scissoring bar 050716	Double pads 050723 + Strengthened bar 051171 + Extensions (x2) 052451	Multihook heads 049758 + 049734 + 049741	3 lifting rods 050792	Dent box consumables 051515	Empty box 320x 113mm	Magnetic earth 049666	Fast pulling rings (x5) 058712 + Alu puller 051003	Arc puller premium 065161	4 m³ support 059665 + Flanges (x2) 062146

<b>39.02</b> 028012	GYSPOT <b>39.02</b>					✓									
<b>39.04</b> 028029	GYSPOT <b>39.04</b>														
<b>PRO 230</b> 036420	GYSPOT <b>PRO 230</b>														
<b>PRO 400</b> 036437	GYSPOT <b>PRO 400</b>														
<b>EXPERT 200</b> 036734	GYSPOT <b>EXPERT 200</b>					✓									
<b>EXPERT 230</b> 067028	GYSPOT <b>EXPERT 230</b>														
<b>EXPERT 400</b> 036741	GYSPOT <b>EXPERT 400</b>														

<b>COMBI 230 E.PRO</b> 036444	GYSPOT <b>COMBI 230 E.PRO</b>	✓	x2					✓					✓		
<b>ARC PULL 200 + PRO 230</b> 069039	GYSPOT <b>ARC PULL 200 + PRO 230</b>														
<b>+ PRO 400</b> 069077	GYSPOT <b>ARC PULL 200 + PRO 400</b>														
<b>+ EXPERT 200</b> 065321	GYSPOT <b>ARC PULL 200 + EXPERT 200</b>	✓	x2					✓							✓
<b>+ EXPERT 230</b> 067035	GYSPOT <b>ARC PULL 200 + EXPERT 230</b>														
<b>+ EXPERT 400</b> 065338	GYSPOT <b>ARC PULL 200 + EXPERT 400</b>														

## DENTSTATION PREMIUM

GYSPOT (guns & consumables included)	Dentstation Pro 056848 + Fixing kit 051362	Cable support 052284	Manuspot 050679	Ringmatic 052154 + Manual pulling handle 057289	Manual pulling handle 057289 + Premium levelling lever 059290 + Premium levelling bar 059306 + Premium scissoring bar 058996 + Premium levelling lever 1200 059313	Premium double pads support 150 mm 059351 + 220 mm 059375	Hook head 049734 + 059658 + 059382	3 lifting rods 050792	Dent box consumables 051515 + Empty box 320x 113mm	Magnetic earth 049666	Fast pulling rings (x5) 058712 + Alu puller 051003	Arc puller premium 065161	4 m³ support 059665 + Flanges (x2) 062146

<b>PRO 230</b> 028067	GYSPOT <b>PRO 230</b>														
<b>PRO 400</b> 028074	GYSPOT <b>PRO 400</b>														
<b>EXPERT 200</b> 036758	GYSPOT <b>EXPERT 200</b>														
<b>EXPERT 230</b> 067042	GYSPOT <b>EXPERT 230</b>														
<b>EXPERT 400</b> 036765	GYSPOT <b>EXPERT 400</b>														

<b>COMBI 230 E.PRO</b> 036772	GYSPOT <b>COMBI 230 E.PRO</b>	✓	x2					✓					✓		
<b>COMBI ARCPULL</b> 074941	GYSPOT <b>COMBI ARCPULL</b>														
<b>ARC PULL 200 + PRO 230</b> 069046	GYSPOT <b>ARC PULL 200 + PRO 230</b>														
<b>+ PRO 400</b> 069084	GYSPOT <b>ARC PULL 200 + PRO 400</b>														
<b>+ EXPERT 200</b> 065345	GYSPOT <b>ARC PULL 200 + EXPERT 200</b>	✓	x2					✓							✓
<b>+ EXPERT 230</b> 067059	GYSPOT <b>ARC PULL 200 + EXPERT 230</b>														
<b>+ EXPERT 400</b> 065352	GYSPOT <b>ARC PULL 200 + EXPERT 400</b>														



COMPLETE SYSTEM

★ ★ ★



065338

- ✓ COMBI 230 E.PRO
- ✓ ARC PULL 200 + PRO 230
- ✓ ARC PULL 200 + PRO 400
- ✓ EXPERT 200 + ARC PULL 200
- ✓ EXPERT 230 + ARC PULL 200
- ✓ EXPERT 400 + ARC PULL 200

DENTSTATION ALU + ACIER / STEEL / STAHL

- ✓ 39.02, 39.04
- ✓ PRO 230, PRO 400
- ✓ EXPERT 200, EXPERT 230, EXPERT 400

036741

DENTSTATION ACIER / STEEL / STAHL

PREMIUM COMPLETE SYSTEM

★ ★ ★ ★



065352

- ✓ COMBI 230 E.PRO
- ✓ COMBI ARC PULL
- ✓ ARC PULL 200 + PRO 230
- ✓ ARC PULL 200 + PRO 400
- ✓ EXPERT 200 + ARC PULL 200
- ✓ EXPERT 230 + ARC PULL 200
- ✓ EXPERT 400 + ARC PULL 200















DENTSTATION PREMIUM ALU + ACIER / STEEL / STAHL















- ✓ PRO 230, PRO 400
- ✓ EXPERT 200, EXPERT 230, EXPERT 400

036765

DENTSTATION PREMIUM ACIER / STEEL / STAHL

# DENTSTATION PREMIUM PRO

 <b>GYSPOT EXPERT 230</b> (guns & consumables included) 066885	 <b>Dentstation Pro WD</b> 072800	 Manuspot 050679	 Ringmatic 052154	 Manual pulling handle 057289	 3 lifting rods 050792	 Dent box consumables 051515	 Magnetic earth 049666	 <b>Levelling bar &amp; scissoring bar Premium Pro</b> 072305 - 071643 072619 - 072626	 071650 072312	 Gripping hook head 072664 - 072671 072640 - 072657	 Double padded feet 270 mm 072688
											
<b>GYSPOT EXPERT 230 + DENTSTATION PRO WD + STEEL ACCESSORIES PACK = 073845</b>											

 <b>GYSPOT EXPERT 400</b> (guns & consumables included) 058859	 <b>Dentstation Pro WD</b> 072800	 Manuspot 050679	 Ringmatic 052154	 Manual pulling handle 057289	 3 lifting rods 050792	 Dent box consumables 051515	 Magnetic earth 049666	 <b>Levelling bar &amp; scissoring bar Premium Pro</b> 072305 - 071643 072619 - 072626	 071650 072312	 072664 072671 072640 072657	 Double padded feet 270 mm 072688
											
<b>GYSPOT EXPERT 400 + DENTSTATION PRO WD + STEEL ACCESSORIES PACK = 073852</b>											

 <b>GYSPOT COMBI ARCPULL</b> (guns & consumables included) 069824	 <b>Dentstation Pro WD</b> 072800	 Manuspot 050679	 Ringmatic 052154	 Manual pulling handle 057289	 3 lifting rods 050792	 Dent box consumables 051515	 Magnetic earth 049666	 <b>Levelling bar &amp; scissoring bar Premium Pro</b> 072305 - 071643 072619 - 072626	 071650 072312	 072664 072671 072640 072657	 Double padded feet 270 mm 072688	 Potence pour servantes de débousselage 052284	 4 m³ support 059665	 Arc Puller Premium Pro 072572
														
<b>GYSPOT COMBI ARCPULL + DENTSTATION PRO WD + STEEL ACCESSORIES PACK + ALU ACCESSORIES PACK = 073869</b>														

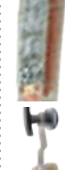
 <b>GYSPOT EXPERT 400 + ARCPULL 200</b> (guns & consumables included) 058859 + 057470	 <b>Dentstation Pro WD</b> 072800	 Manuspot 050679	 Ringmatic 052154	 Manual pulling handle 057289	 3 lifting rods 050792	 Dent box consumables 051515	 Magnetic earth 049666	 <b>Levelling bar &amp; scissoring bar Premium Pro</b> 072305 - 071643 072619 - 072626	 071650 072312	 072664 072671 072640 072657	 Double padded feet 270 mm 072688	 Potence pour servantes de débousselage 052284	 4 m³ support 059665	 Arc Puller Premium Pro 072572
														
<b>GYSPOT EXPERT 400 + ARCPULL 200 + DENTSTATION PRO WD + STEEL ACCESSORIES PACK + ALU ACCESSORIES PACK = 073876</b>														

 <b>GYSPOT EXPERT 400 + ARCPULL 350</b> (guns & consumables included) 058859 + 062191	 <b>Dentstation Pro WD</b> 072800	 Manuspot 050679	 Ringmatic 052154	 Manual pulling handle 057289	 3 lifting rods 050792	 Dent box consumables 051515	 Magnetic earth 049666	 <b>Levelling bar &amp; scissoring bar Premium Pro</b> 072305 - 071643 072619 - 072626	 071650 072312	 072664 072671 072640 072657	 Double padded feet 270 mm 072688	 Potence pour servantes de débousselage 052284	 4 m³ support 059665	 Arc Puller Premium Pro 072572	 Alu Ring Box 1,5 mm 059429
															
<b>GYSPOT EXPERT 400 + ARCPULL 350 + DENTSTATION PRO WD + STEEL ACCESSORIES PACK + ALU ACCESSORIES PACK = 076020</b>															

**NEW**



## STEEL ACCESSORIES



073845

DENTSTATION PREMIUM PRO EXPERT 230

## STEEL ACCESSORIES



073852

DENTSTATION PREMIUM PRO EXPERT 400

## STEEL &amp; ALU ACCESSORIES



073869

DENTSTATION PREMIUM PRO COMBI ARCPULL

## STEEL &amp; ALU ACCESSORIES

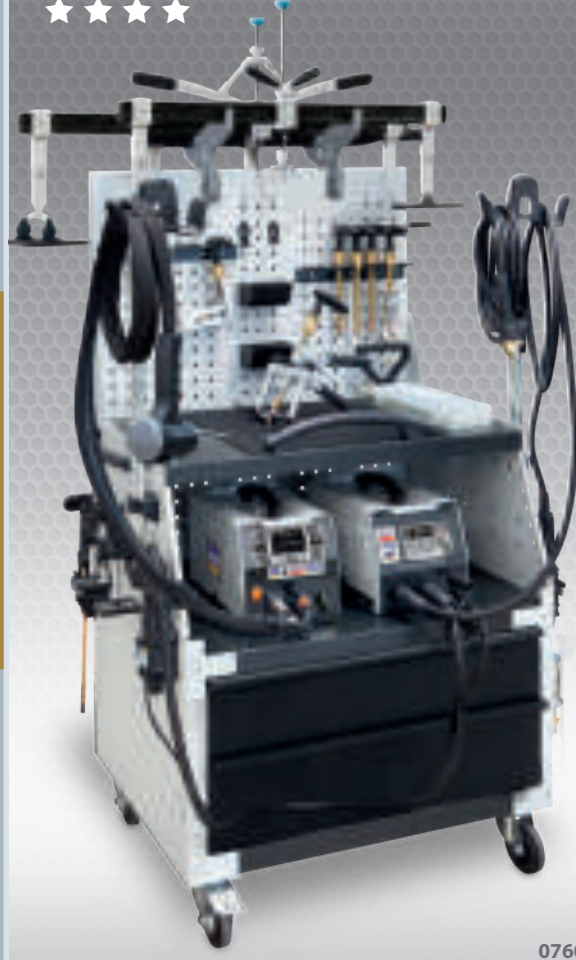

076020

DENTSTATION PREMIUM PRO  
EXPERT 400 + ARCPULL 200, 350



# PULLING SYSTEMS

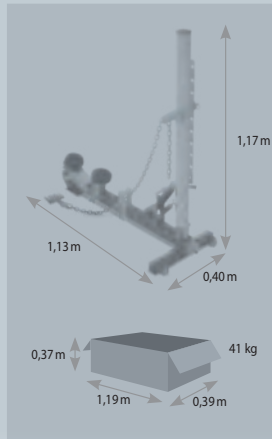
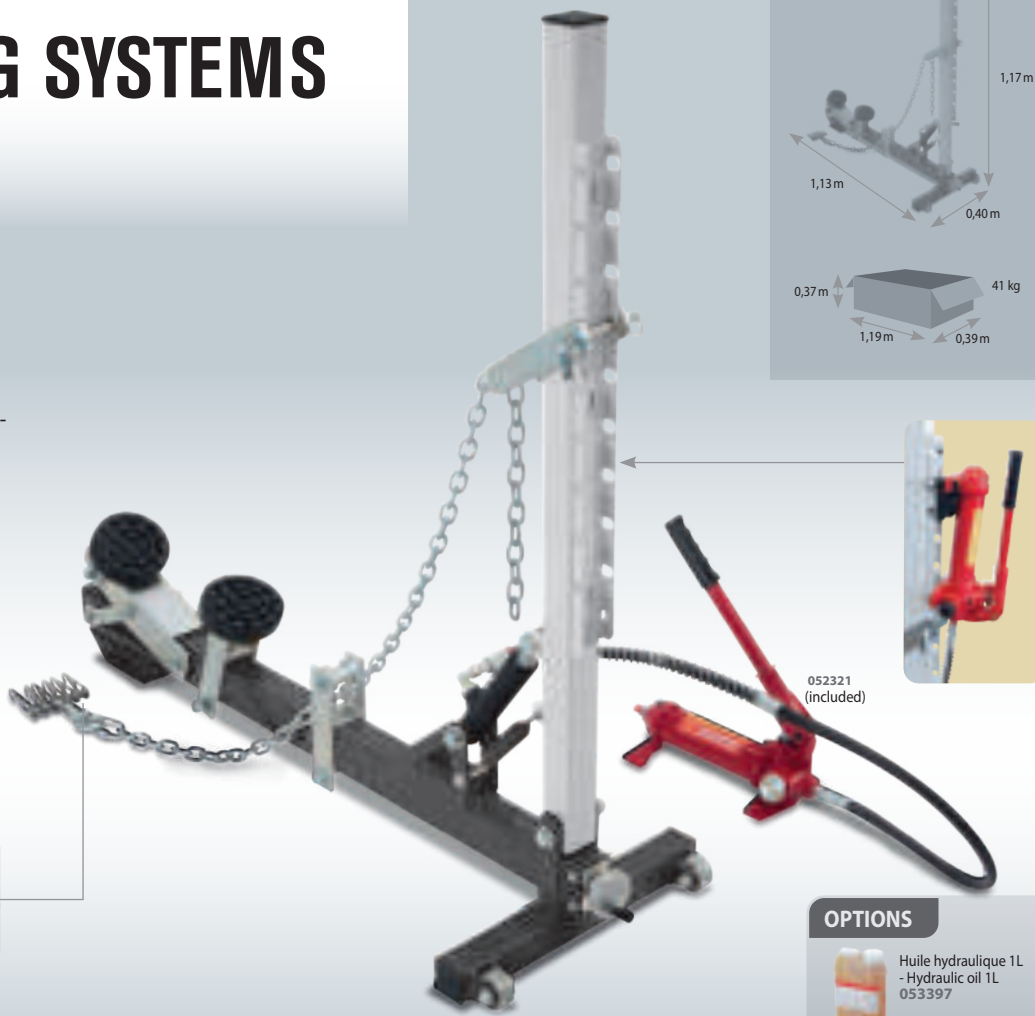
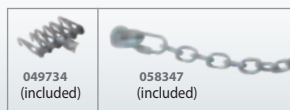
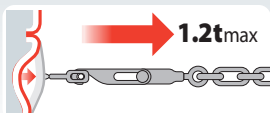

**DRAW ALIGNER**

Équerre de tirage - Draw aligner -  
Schnellausbeul-Richtausleger  
052475

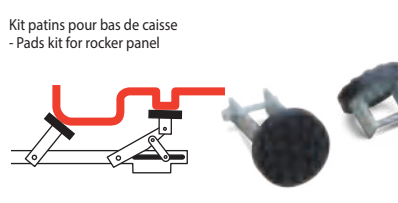
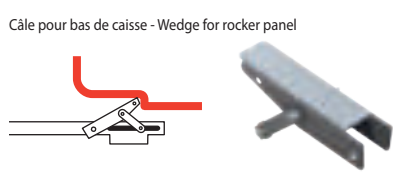

**OPTIONS**

Huile hydraulique 1L  
- Hydraulic oil 1L  
053397

**INCLUDED**

**OPTIONS**

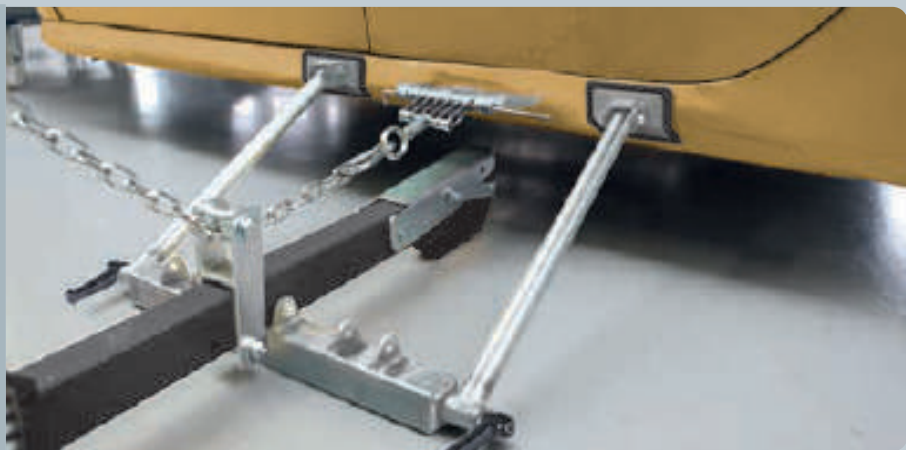
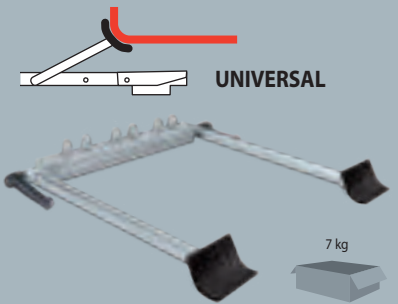
Bras de bas de caisse - Rocker panel arms for draw aligner -  
Abstütztraverse für Richtausleger

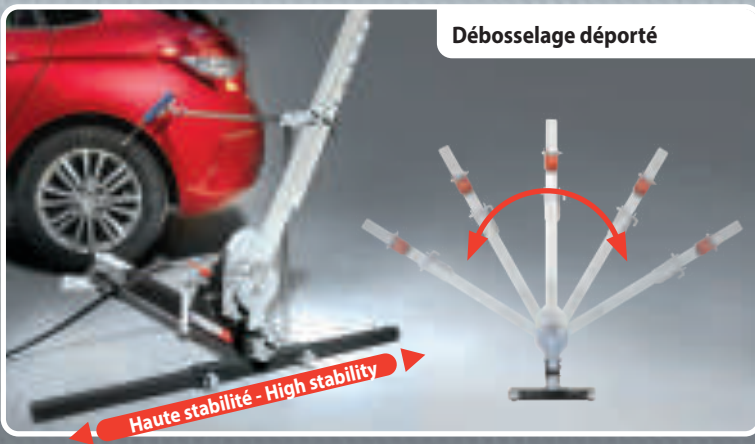

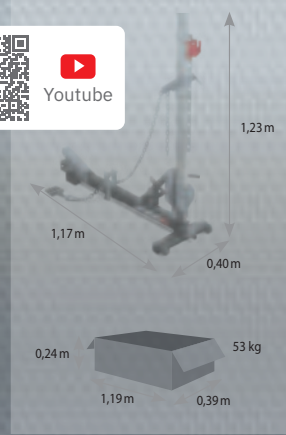

Youtube



**DRAW ALIGNER PRO**  
069244

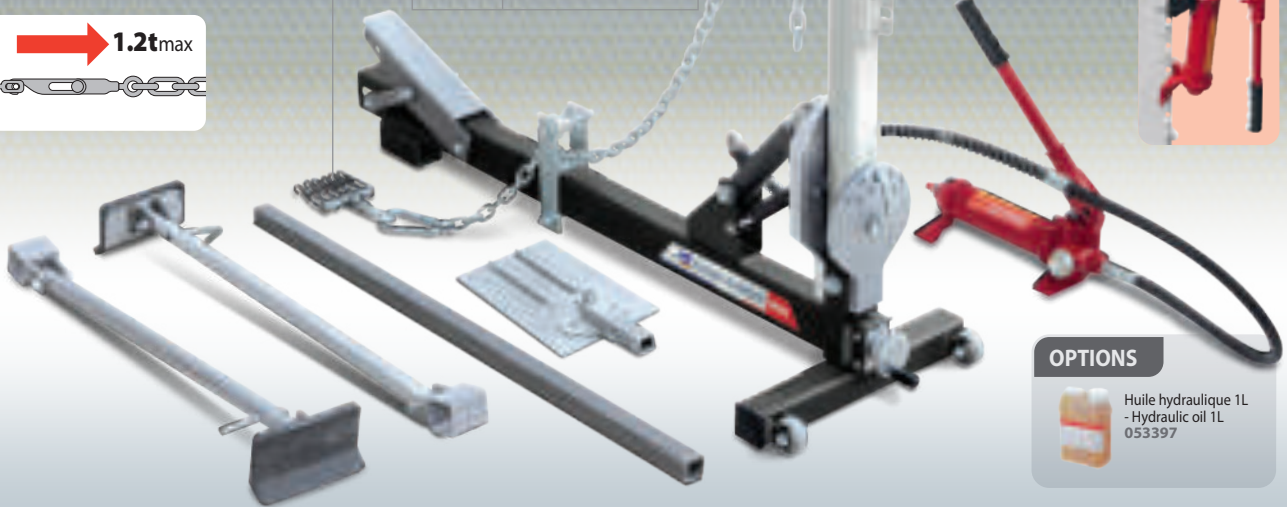
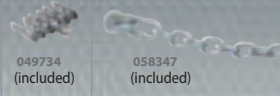
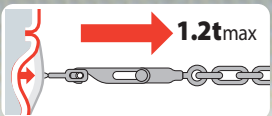

**OPTIONS**

Huile hydraulique 1L  
- Hydraulic oil 1L  
053397

**INCLUDED**

Câle sous roue - Plate under the wheel **076693**

Câle pour bas de caisse - Wedge for rocker panel

Kit bras de bas de caisse et barre de stabilisation - Rocker panel arms and stabilisation bar

**OPTIONS**

Kit patins pour bas de caisse - Pads kit for rocker panel  
071278





# SYSTÈME DE TIRAGE SMART PULLER SILVER

- Smart puller silver pulling system - Schnellausbeul-Richtausleger Smart puller silver

054820

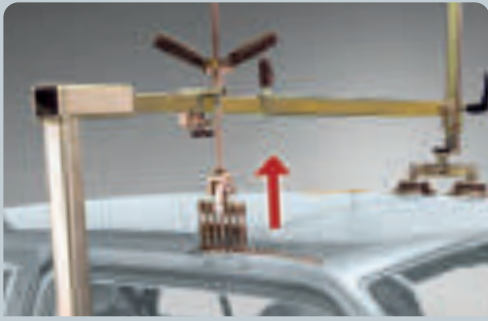

- Portières - Doors - Türen
- Montants - Supports - Scheibenrahmen
- Capot - Hood/Bonnet - Haube
- Armature - Armature - Rahmen
- Bas de caisse - Rocker panel - Schweller
- Ailes - Wings - Kotflügel
- Toit - Roof - Dach
- Hayon - Hatchback - Heckdeckel

**Autorobot®**

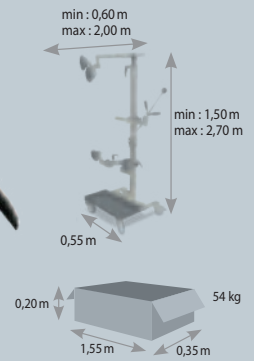

**INCLUDED**

Accessories



Spreading / Estensione

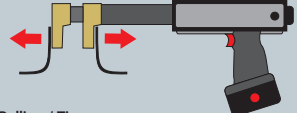

Pressing / Compressione

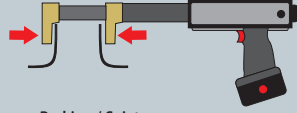

Pulling / Tiro



Pushing / Spinta



Applications / Applicazioni

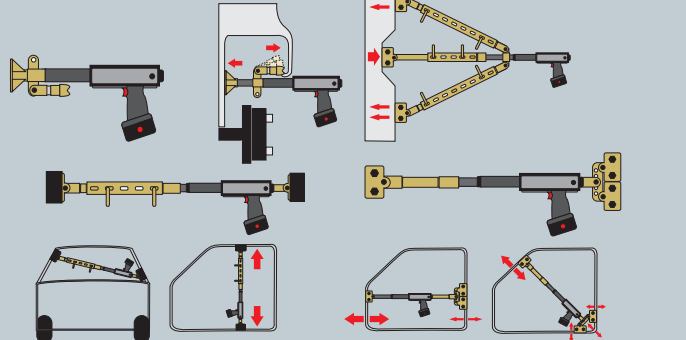

## ELECTRO POWER - Zug-Druckpresse

Non commercialisable en France

with accessories:  
057425

- PULLING POWER: 5 Ton.
- PUSHING POWER: 5 Ton.
- PISTON
- STROKE: 130 mm



INCLUDED



Standard kit : 425x620x210 mm  
Standard kit Total weight: 18 kg  
057401

INCLUDED



Accessories kit : 425x620x150 mm  
Accessories kit Total weight: 20 kg  
057418

Li-Ion battery (included)  
058514



**BASIC 4T**  
052345



**BASIC 10T**  
052338



**PRO 4T**  
057432



**PRO 10T**  
057449



**OPTIONS**



Huile hydraulique 1L  
- Hydraulic oil 1L  
053397

**BARRE D'ANCRAGE** - Anchor bar - Türspanner

MADE IN TAIWAN

053045

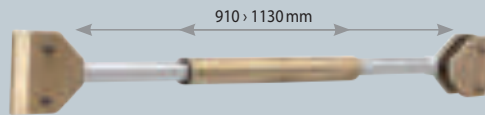

053052

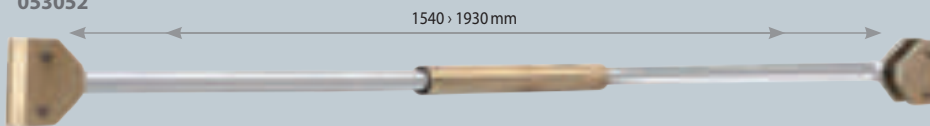

**MESURES** - Measuring tools - Vermessung

**BODYMETER**, Mechanical measurements

052130

250 > 2230 mm



**GYSMETER**, Electronic measurements

052093

Measuring report

Measured values	
Line 1: 1000 μl	Line 4: 1000 μl
Line 2: 1070 μl	Line 5: 900 μl
Line 3: 1070 μl	Line 6: 1070 μl



Light weight measuring arm with an easy to read digital display



400 > 2650 mm

**PINCE PIVOTANTE**  
- Swivel clamp



**PINCES DE TIRAGE - Frame Straightening - Ziehwerkzeuge**

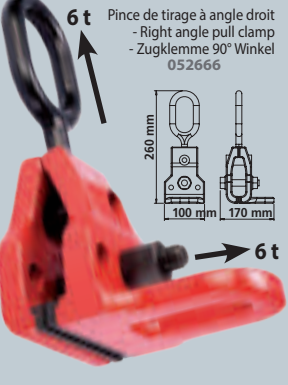
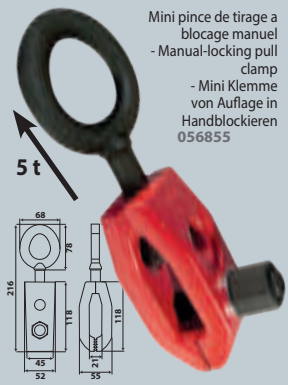

**CROCHET DE TIRAGE - Frame Straightening - Ziehwerkzeuge**

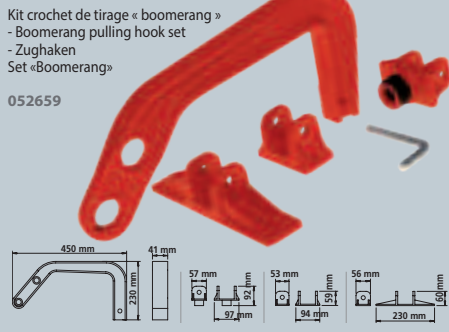

**PASSAGE DE ROUE - Arch hooks**

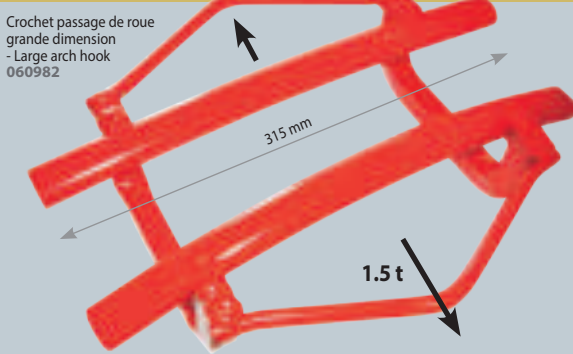
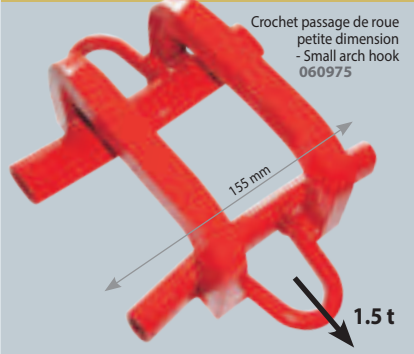

**CHAÎNES DE TIRAGE - Frame Straightening - Ziehwerkzeuge**

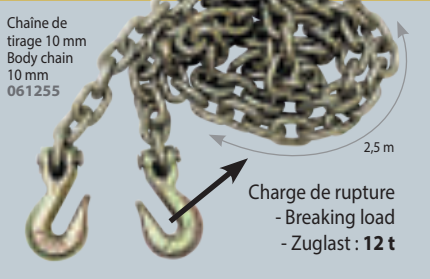
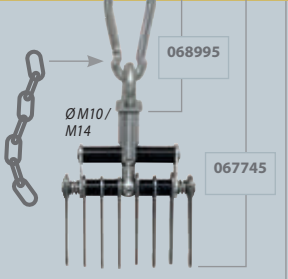
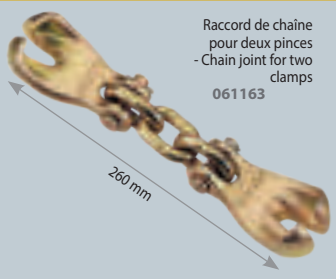
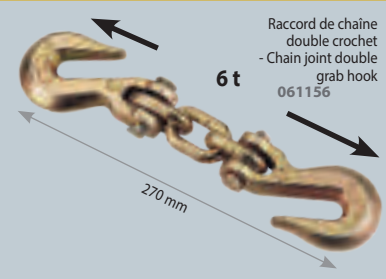

**PINCES DE TIRAGE LARGES - Wide pull clamps**

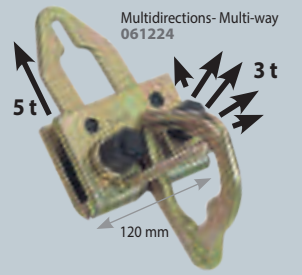
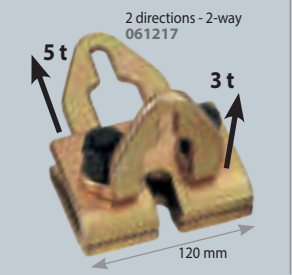

**PINCES DE TIRAGE FAIBLE LARGEUR - Small pull clamps**

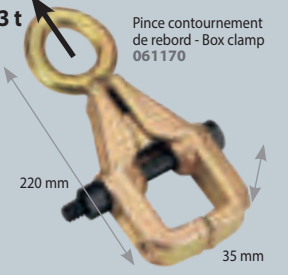
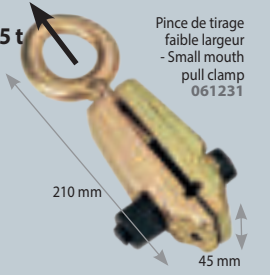
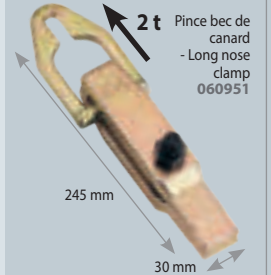

**PINCE DE TIRAGE MULTIPLE**  
- Multiple pull clamp

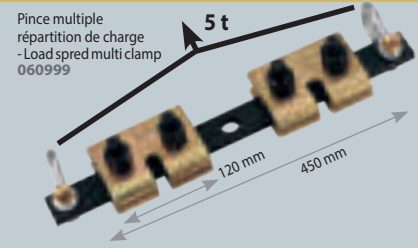

**PINCE CISEAUX LARGEUR**  
45 mm - 45 mm scissors clamp

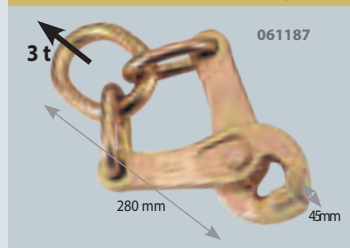

**PINCE DE TIRAGE POUR ANGLE 90°**  
- 90 Degree corner clamp

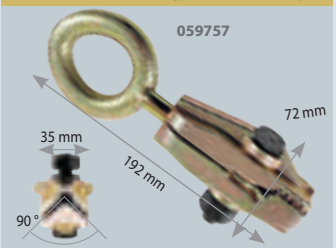

**PINCE DE TIRAGE TYPE C**  
- C type clamp



**KIT MARTEAU À INERTIE** - Inertia hammer kit - Ausziehhammer kit

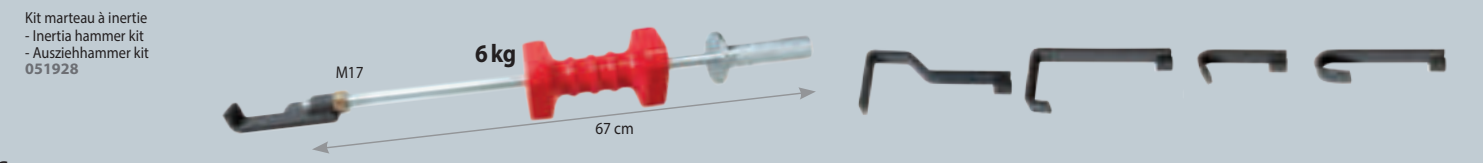



The best from **Autorobot**  
 www.autorobot.com/pdf/714B\_ENG.pdf  
 MADE IN FINLAND

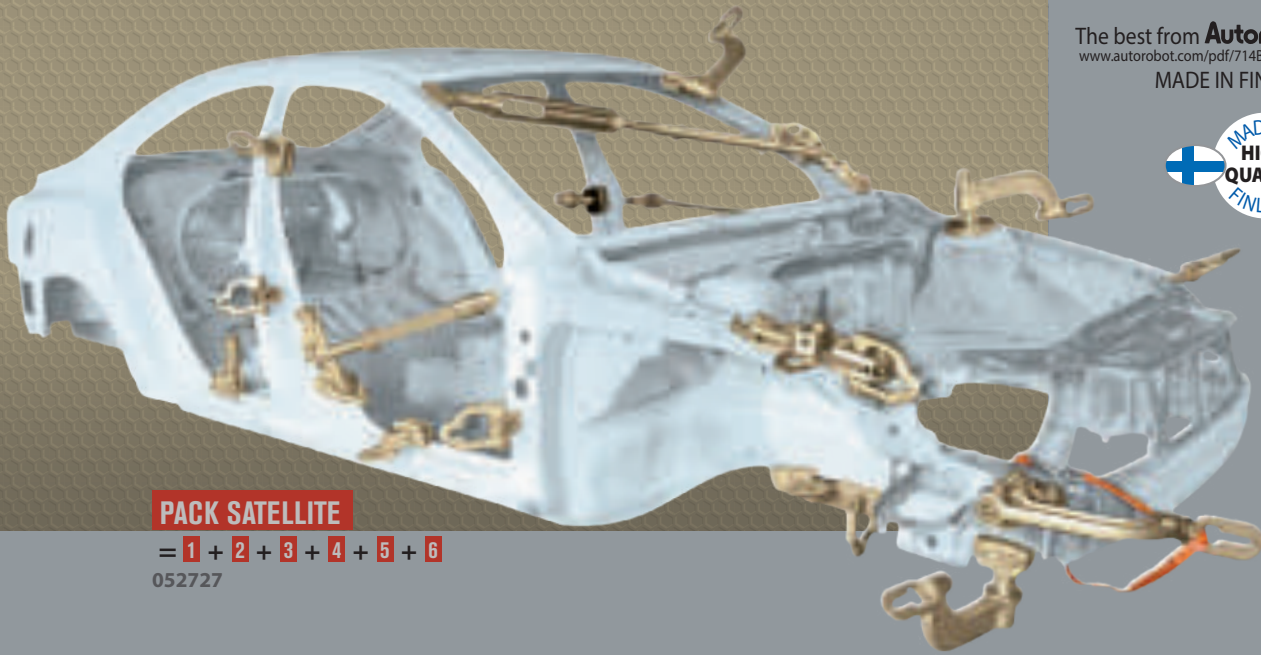

**PACK SATELLITE**

= 1 + 2 + 3 + 4 + 5 + 6  
 052727

**1 SATELLITE**  
 - Satellite - Satellite Basisbügel-Set

052710



**2 KIT MAC PHERSON (A)**  
 - Mac Pherson Kit - Befestigungs-  
 Federbein (McPherson)

052703



**3 BARRE POUR TIRER/POUSSER**  
 - Push/Pull Bar  
 - Zug/Druck-Stangenset

052673



**4 SATELLITE (B)**  
 - Bügelverlängerung

052680



**5 SANGLE DE SÉCURITÉ**  
 - Safety Strap - Sicherungsgurt

044036



**6 DOUBLE PINCE SATELLITE (C)**  
 - Double Clamp Satellite  
 - Satellite Doppelklemme

052697



**PINCE DE TIRAGE MULTI-USAGE**  
 - Versatile pulling clamp  
 - Multifunktions-Zugklemme

053571

**Autorobot**

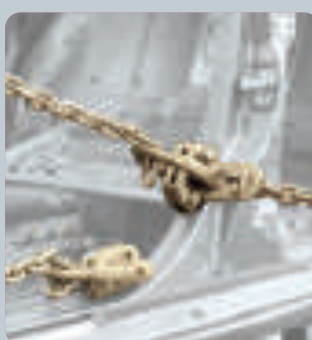

**POWER-PULLER 4T**

059740



**HIGH QUALITY**





Débosselage rapide et sans peinture  
- PDR: Paintless Dent  
Repair  
- Lackschadenfreies Ausbeulen

# PAINTLESS DENT REPAIR

## INDUCTEUR DÉBOSSELAGE - Dent Pulling Inductor - Dellenmatrix



GYSDUCTION  
AUTO

+ Dent pulling  
inductor  
054776

= GYSDUCTION AUTO  
DENT REPAIR  
054981



MADE IN FRANCE



3 m

Licensed by  
BETAG.Innovation

## INSPECTION CARROSSERIE - Dent Pulling Inductor - Ausbeul Induktor

Planche flexible pour inspection  
de la carrosserie - Ausbeul-  
Matrix  
Ø 800 mm  
059122

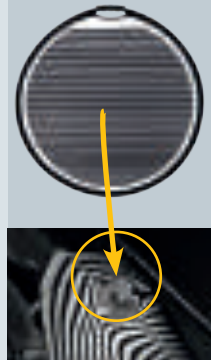

OPTION  
Spray refroidisseur  
- Freezer spray  
-50 °C  
400 ml  
(x 12)  
048898

Cable (m)	Inductor	cm	kg	INTEGRATED TECHNOLOGY			Liquid Cooling	Cable (m)	Inductor	cm	kg
				PFC	FV						
50 Hz	A	W	kHz	■	■	—	2	2,5	22 x 36 x 27	7,5	
230 V, 1~	16	2 400	35+120								

## KIT MAGNÉTIQUE DE DÉBOSSELAGE SANS PEINTURE - Paintless Dent Repair magnetic kit - Magnetisches Ausbeul-Kit

053168

EXELTOOLS



1010mm - 40"

705mm - 28"

610mm - 24"

510mm - 20"

## LAMPES DE DÉBOSSELAGE - Paintless Dent Repair lamps - Ausbeullampe

ULTRA LIGHT CARBON X40 PW  
053175

EXELTOOLS

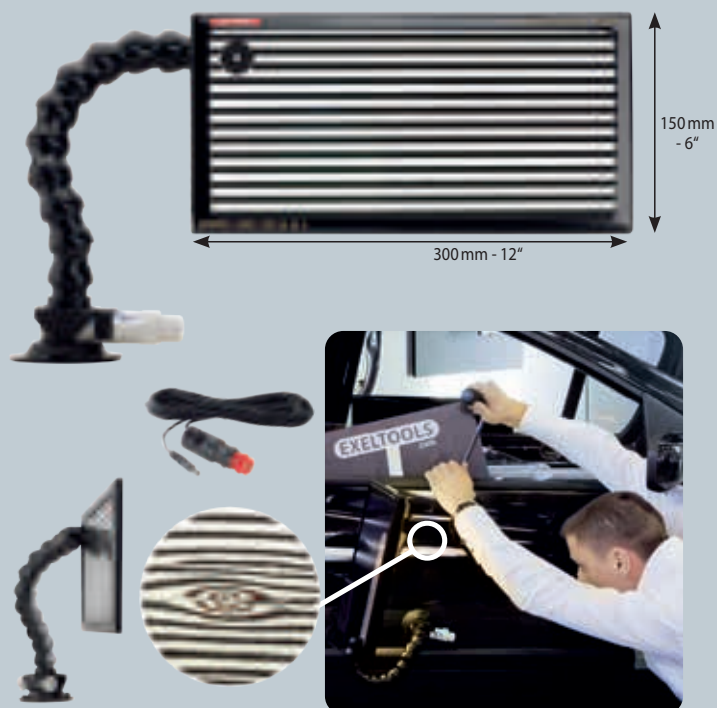

300mm - 12"

150mm  
- 6"

**KIT DÉBOSELAGE SANS PEINTURE**  
- Dent Pulling Kit (paintless) - Dellenausbeulhebel-Set

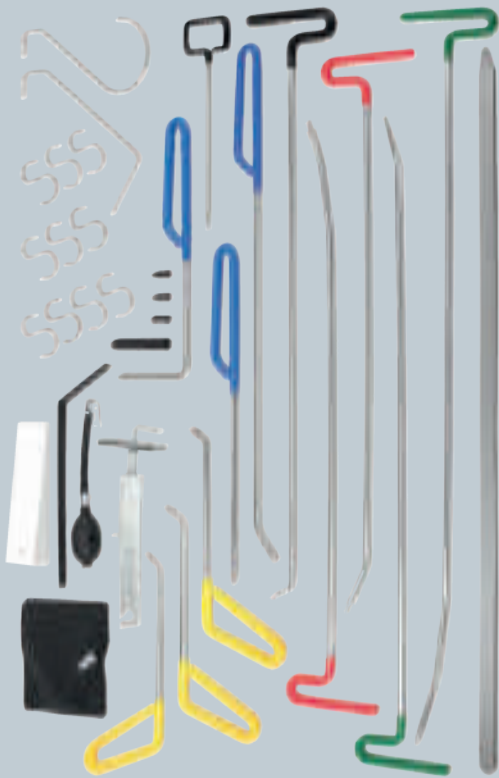

33 parts

051959



**KIT COUSSINS GONFLABLES**  
- Air Cushion Kit - Luftpolster-Spreizkissen-Satz



051942

**KIT DE 6 COINS DE FRAPPE** - Set of 6 pencil punches - Beulenstemmer-Satz mit 6 Tefloneinsätzen



052888



MADE IN FRANCE

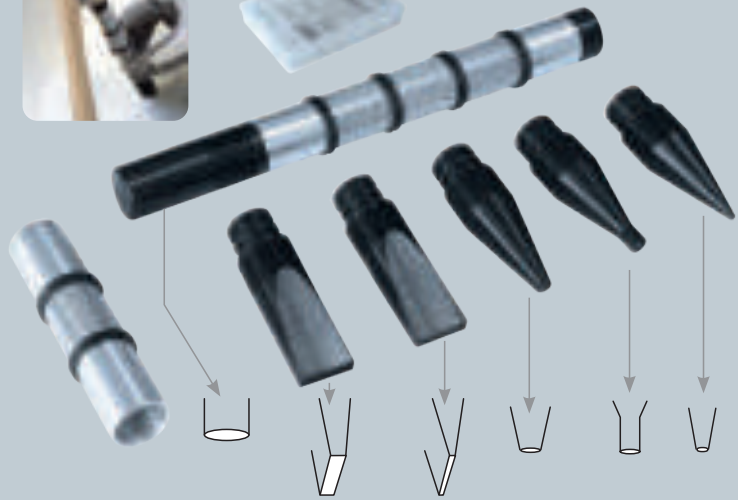

**MARTEAU INERTIE PNEUMATIQUE** - Pneumatic inertia hammer - Unterdruck-Schlaghammer



051904

**MARTEAU À INERTIE À VENTOUSES (POMPAGE MANUEL)**  
- PUMP AIR SUCTION SLIDE HAMMER - Man. Unterdruck-Schlaghammer



048683



Débosselage rapide et sans peinture  
- PDR: Paintless Dent Repair  
- Lackschadenfreies Ausbeulen

# PAINTLESS DENT REPAIR

## BARRETTES ANNEAUX PLASTIQUE Plastic Multipads Ösen-Klebe pads

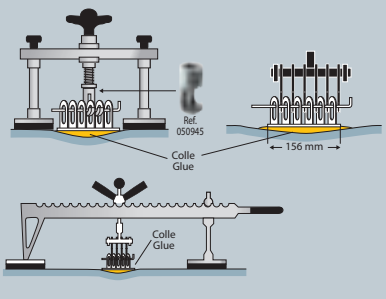

## GLUE PULLER PRO (Acier/Alu • Steel/Alu)



Glue Puller PRO  
058699

Glue Puller PRO  
EXPORT  
230 V 059160



## OPTIONS

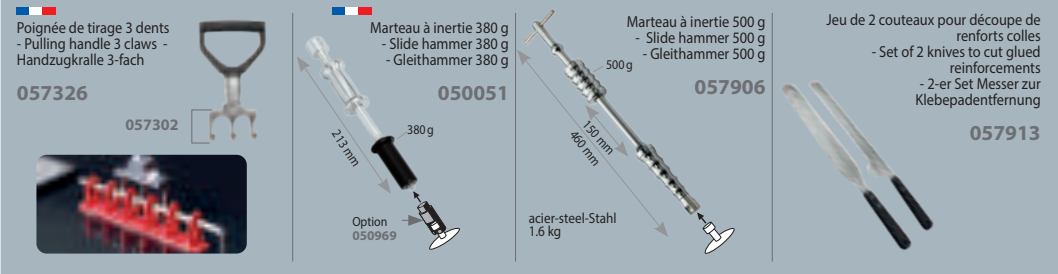

## GLUE PULLING KITS

### GYSMART GLUE PULLING KIT

NEW



### GYSMART GLUE PULLING KIT PLUS

NEW



Workstation 054233	Set of pencil punches with 6 teflon tips 052888	Infrared thermometer 052994 Heat Gun 066311	Levelling bar 050693 6 Gripping multihook head 049734	3 Lifting rods 150/300/500 mm 050792	Set of 3 conical plastic multipads 048096 048072 048089 048119 048102	Inertia hammer 057906	Set of 6 glue tips 050952	Glue Puller PRO 058699	Glue Puller PRO Export 059160	33PC Paintless dent repair kit 051959 PDR Light ultra light carbon X40PW 053175	Mini puller 050921 Aluminium clamp 2 050945
--------------------	---	--	--	--------------------------------------	---	-----------------------	---------------------------	------------------------	-------------------------------	--	--

GYSMART GLUE PULLING KIT  
076051

GYSMART GLUE PULLING KIT  
EXPORT  
076105

GYSMART GLUE PULLING KIT PLUS  
076082

GYSMART GLUE PULLING KIT PLUS  
EXPORT  
076129







# TRUCK TOOLS

41

TRUCK TOOLS



## TROLLEY IW1

Impact wrench trolley -  
Support de clé à choc

max 6.5 bar

max 20 kg

063136

### OPTIONS



Huile hydraulique  
- Hydraulic oil  
1 l  
053397



Youtube

Suppression du poids,  
des vibrations et du couple  
- Weight, vibrations  
& torque suppression

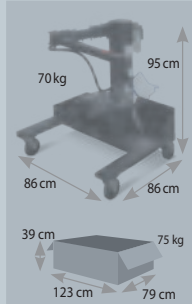
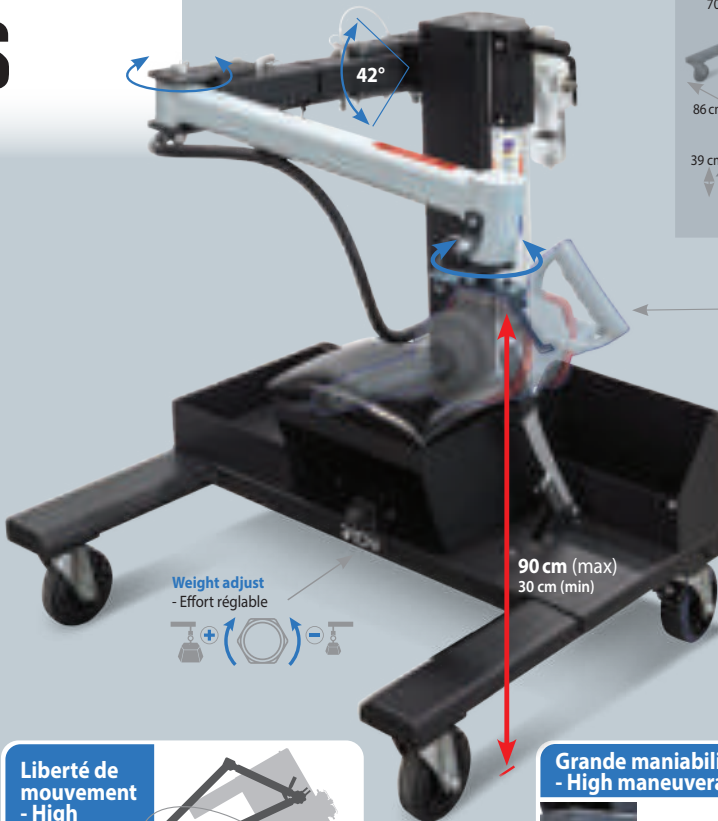

Clé à choc  
- Impact wrench  
max 20 kg

Fixation  
36 x 36 mm  
→ 44 x 44 mm

Weight adjust  
- Effort réglable



90 cm (max)  
30 cm (min)

Liberté de  
mouvement  
- High  
dexterity

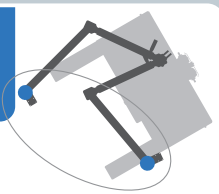

Grande maniabilité et stabilité  
- High maneuverability & stability



## MULTITOOL TRUCK

NEW  
01 / 2023

SAFE EN 14238 + A1

max 200 kg

067158

### INCLUDED



Outil de levage pour étrier de  
frein - Lifting tool for brake  
caliper - Hebewerkzeug für  
Bremssattel

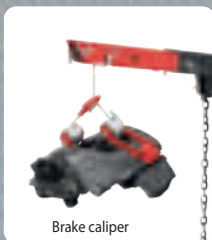

Brake caliper



Outil de levage pour batterie  
- Lifting tool for battery -  
Hebewerkzeug für Batterie



Truck batteries



Outil de levage pour roues  
- Lifting tool for wheels  
- Hebewerkzeug für Räder

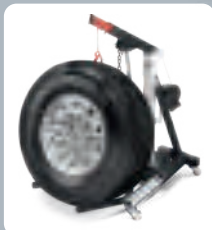

SAFE  
EN 14238 + A1

ULTRA  
COMPACT  
103 cm

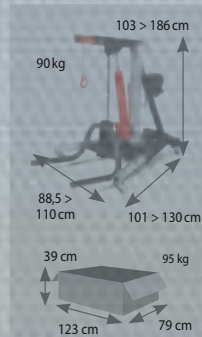

### HEALTH CARE

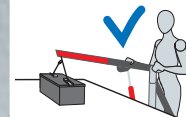

90°

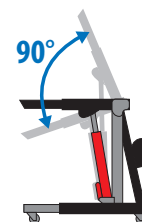



SPOT LIFT

# MOBILE LIFTS



## SPOT LIFT EASY

max Air 8 bar

SAFE EN 1494

max 2.2 t



064843

SAFE EN 1494

### OPTIONS



Huile hydraulique - Hydraulic oil 1 l 053397



Outil de levage pour bas de caisse - Rocker panel lifting tool - Auflage für Seitenschweller 053236

### HEALTH CARE

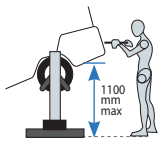

### Haute stabilité - High stability

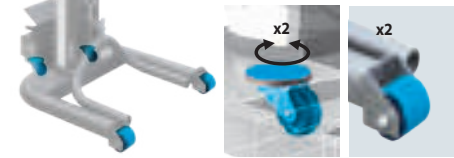

Included 220 bar 053588

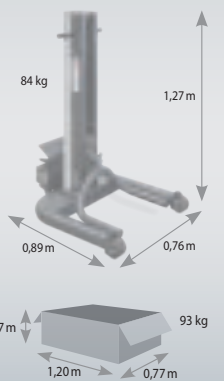

### AUTO ROLL



min 500 mm  
max 1700 mm (AUTOROLL 1.0m)  
max 2240 mm (AUTOROLL 1.55m)

2.5 t max

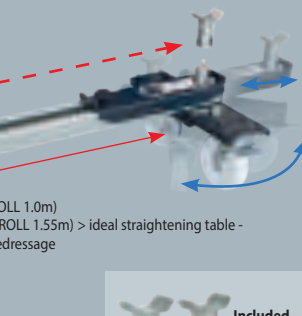

1.0 m (AUTOROLL 1.0m)  
1.55 m (AUTOROLL 1.55m) > ideal straightening table - idéal table de redresseage

AUTO ROLL 1.0 m / 1.2 t 059047

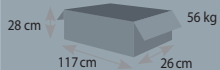

AUTO ROLL 1.55 m / 1.2 t 063839

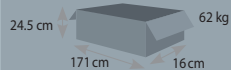

### AFTER LIFT AUTO ROLL

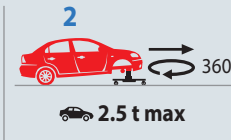

2.5 t max

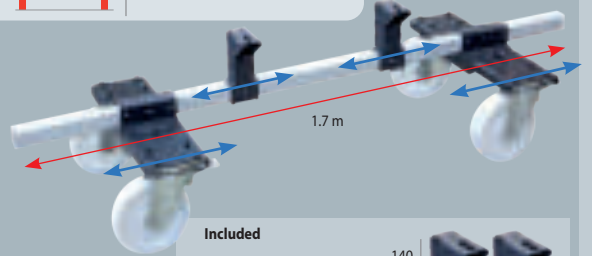

1.7 m

067967

45 Kg

Included

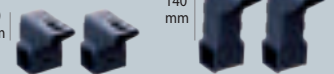

140 mm

### TABOURETS DE MANUTENTION - Wheel trolleys - Radhocker

048768



650 kg max



x 2



26 cm max



### CHARIOTS DE MANUTENTION PRISE SOUS ROUE - Wheel trucks - Kfz-Montagelift, fahrbar

Chariots mécaniques (x 2) - Mechanic jacks (x2) 071995

680 kg max

(2x) 16 kg

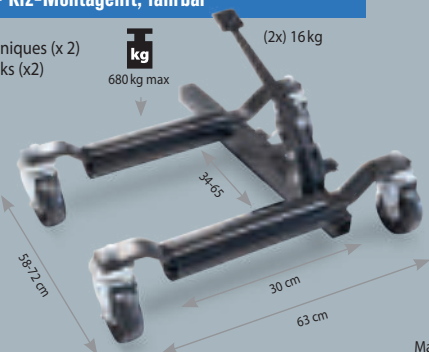

58-72 cm

34-45

30 cm

63 cm

Made in China



**SPOT LIFT PRO**

max Air 8 bar **SAFE EN 1494**

**max 2.2 t**

053557

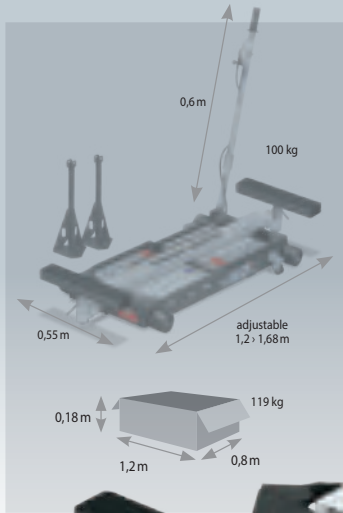

OPTION

**SAFE EN 1494**

60 cm (max)  
14 cm (min)

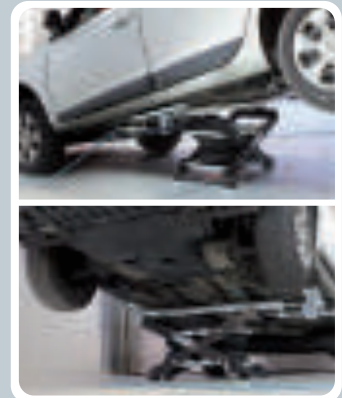

**OPTIONS**

Réhausseur pour 4x4 et utilitaires  
- Height adjuster for 4x4 & utility vehicles  
- Erhöhung f. 4x4 und Leicht-LKW



Patins - Pads  
for Audi & BMW  
(x2)  
053717



Rampes - Ramps  
700 x 200 x 80 mm  
(x2)  
056787

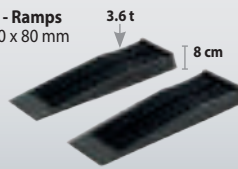

**SPOT LIFT PRO MOB**

max Air 8 bar **SAFE EN 1494**

**max 2.2 t**

055896

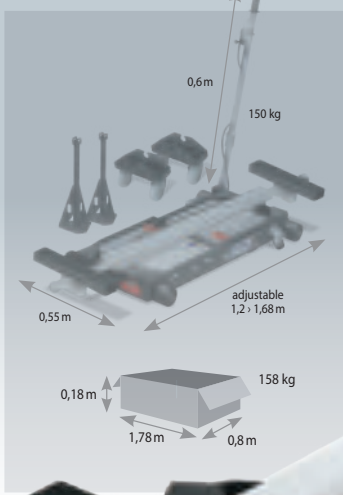

**SAFE EN 1494**

60 cm (max)  
14 cm (min)



**OPTIONS**

**SPOT LIFT PRO MOB**  
Réhausseur pour 4x4 et utilitaires  
- Height adjuster for 4x4 & utility vehicles  
- Erhöhung f. 4x4 und Leicht-LKW



Patins - Pads  
for Audi & BMW  
(x2)  
061606



Rampes - Ramps  
700 x 200 x 80 mm  
(x2)  
056787

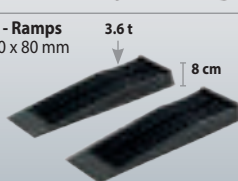

# ERGO LIFT 650

220 V, 1~

**SAFE EN 1493**

**max 2 t**



056817

220 V, 1 ph  
0,75 kW



Included  
Huile hydraulique -  
Hydraulic oil  
5l  
062160



**EASY 360° - Déplacements sur 360°**



Removable wheels

**Haute stabilité - High stability**

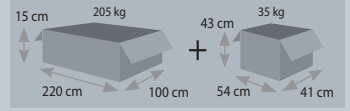

**SAFE EN 1493**

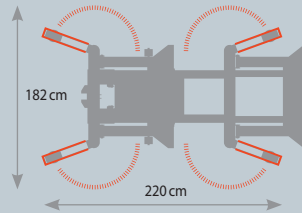
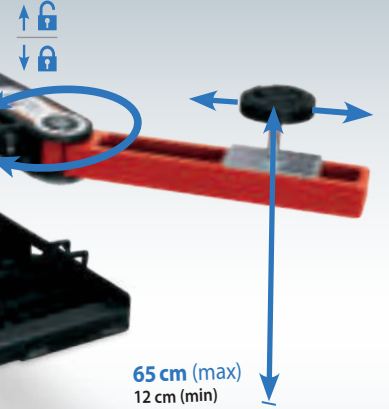
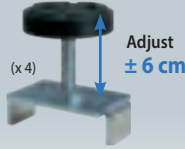

**Pack ERGO LIFT 650 + 4 Wheel trolleys (x4)**

068544



# QUICK LIFT L520E

062184

220 V, 1 ph  
0,75 kW

Included  
Huile hydraulique -  
Hydraulic oil  
5l  
062160

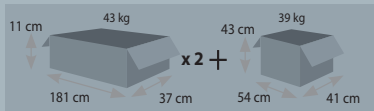

Made in China



Pads - Patins  
Included (x 8)

**SAFE EN 1493**

**2.5 t max**

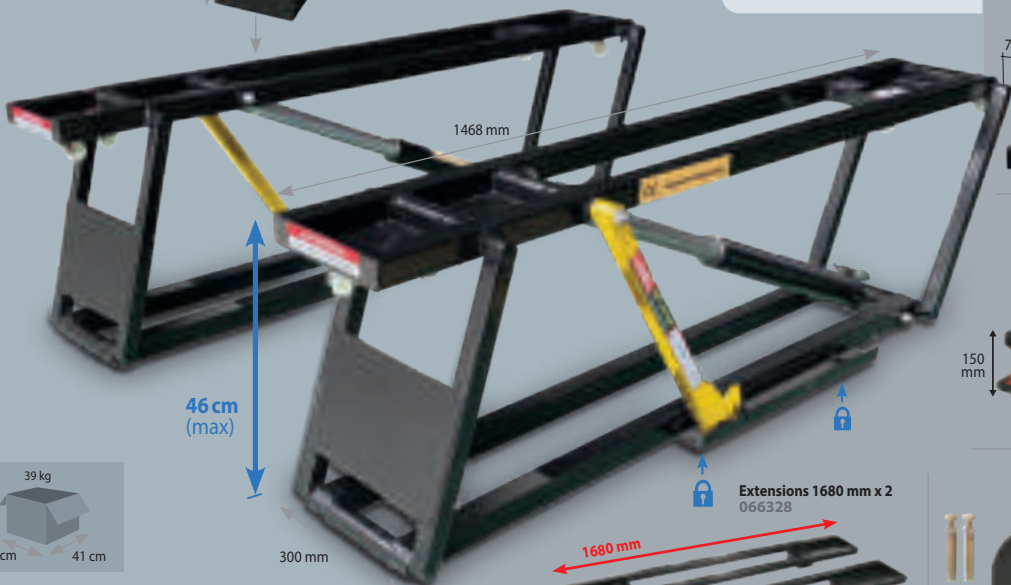

46 cm (max)

1468 mm

300 mm

1680 mm

Extensions 1680 mm x 2  
066328

## OPTIONS

x4 Patins à rainures  
071933

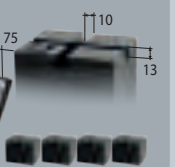

Patins pour SUV -  
Pads for SUV  
x4  
065017



Support mural -  
Wall mount  
071926







**ERGO LIFT 1000 ROLL**

Air 7-8 bars

**SAFE EN 1493**

**NEW**  
11 2022

**SAFE EN 1493**

**max 2.5 t**

076792

included :



Haute stabilité - High stability

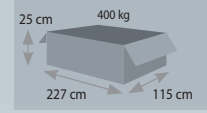

**Pack ERGO LIFT 1000 ROLL + wheels**  
076792



ERGO LIFT 1000 ROLL  
067950

Wheel kit  
076778

**ERGO LIFT 1000 ROLL**  
067950

**no wheels**



**AIR JACKS**



**AIR JACK VAN 2T**  
058330



2T max

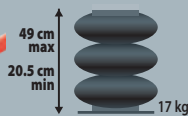

**AIR JACK CAR 2T**  
058323



2T max

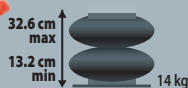

**MANUAL WHEEL LIFT**



**Lève roue à treuil**  
- Wheel lift trolley  
- Radmontage-Heber  
061385

min : R13 / 135 / 65  
max : R22 / 300 / 35  
40 kg max

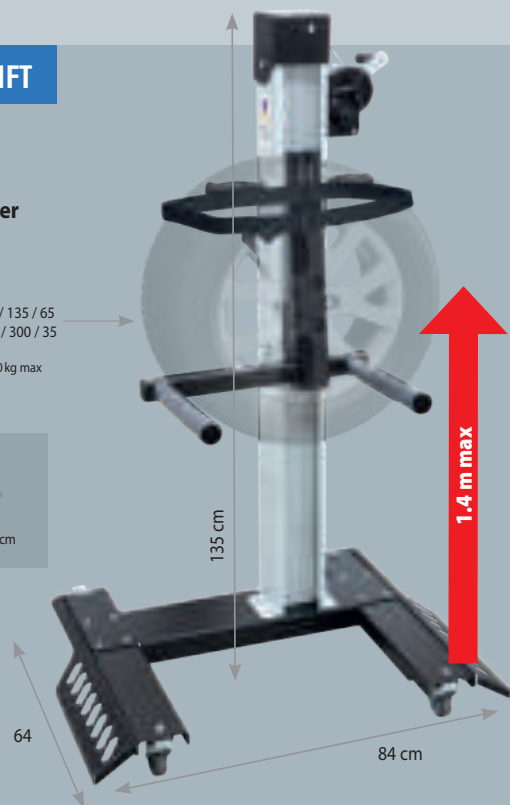
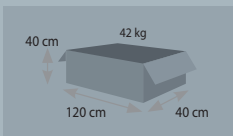

# ÉVOLUTION TECHNOLOGIQUE

TECHNICAL IMPROVEMENTS - TECHNISCHE ENTWICKLUNG - MEJORAS TECNICAS



Facteurs d'évolution :  
 • Challenge CO2 = faible poids  
 • Crash test = ★★★★★  
 • Anti corrosion = nouveaux revêtements  
 • Esthétique et visibilité plus sophistiquées.



Evolution factors :  
 • CO2 Challenge = low weight  
 • Crash test = ★★★★★  
 • Anti-corrosion = new coatings  
 • Improved aesthetics and demand for better occupant visibility.



Entwicklungsfaktoren :  
 • CO2 Challenge = geringes Gewicht  
 • Crash-Test = ★★★★★  
 • Anti-Korrosion = neue Beschichtung  
 • Modernes Technik-Design.



Fattori di evoluzione :  
 • Sfida CO2 = basso peso  
 • Crash test = ★★★★★  
 • Nuovi rivestimenti = anticorrosivi  
 • Estetica e visibilità più sofisticate

2004

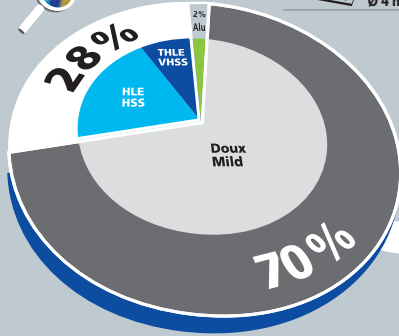

OLD SOLUTIONS

Traditional machines  
 180 daN max  
 6 500 A max  
 X clamps  
 Ø 4 mm max

2023

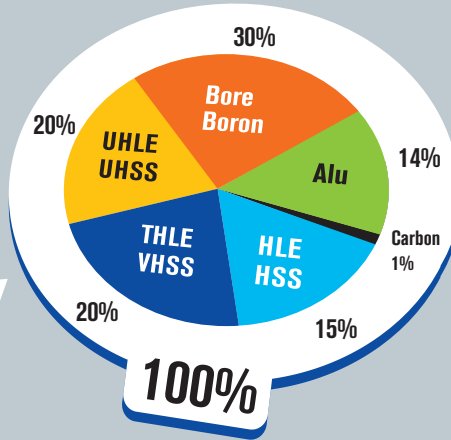

GYS SOLUTIONS

INVERTER Technology  
 550 daN max  
 14 500 A max  
 X & C clamps  
 Liquid cooled system  
 Ø 10 mm

- Mild - Doux
- HSS - HLE
- VHSS - THLE
- UHSS - UHLE
- Bore - Boron
- Aluminium

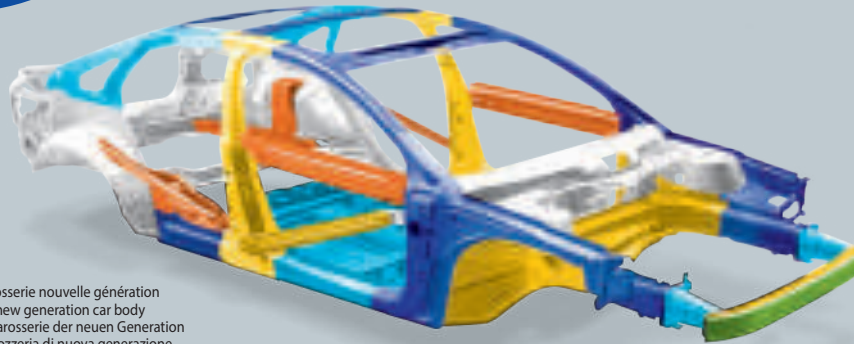

Exemple de carrosserie nouvelle génération  
 • An example of new generation car body  
 • Beispiel einer Karosserie der neuen Generation  
 • Esempio di carrozzeria di nuova generazione

## HOMOLOGATIONS PRODUITS

MANUFACTURER APPROVALS / COMPLIANCE - PRODUKT HOMOLOGATIONEN - PRODOTTI APPROVATI



	Volkswagen Group	Jeep	Mercedes	smart	EvoBus	Nissan	TOYOTA	CHEVROLET	VOLVO	GM	SUZUKI	TATA	EICHER	KIA	Jaguar/Land Rover	Ford USA	Honda USA	NIO	BYD	
DENT PULLER	GYSPOT 2600/2700	●																		
	GYSPOT 39.02/04, PRO230/400	●	●			●	●													●
	EXPERT 200/400	●	●			●	●													●
	PROLINER/SPEEDLINER/DENTSTATION	●	●			●	●													●
	GYSPOT ALU FV	●	●			●	●													
ARCPULL 200	●																			●
RESISTANCE SPOT WELDERS	GYSPOT 32D																			
	GYSPOT INVERTER 100R		●																	
	GYSPOT INVERTER BP-LX	●	●			●	●									●	●			
	GYSPOT INVERTER BP-LC-s7	●	●			●	●									●	●			●
	GYSPOT INVERTER BP-LCX-s7	●	●			●	●									●	●			
	GYSPOT INVERTER BP-LG	●	●			●	●									●	●			
	GYSPOT EVOLUTION PTI-s7	●	●			●	●									●	●			●
GYSPOT INVERTER PTI-G																				
VAS 821 101 - Spot Welder	●																			
RIVE TING	GYSPRESS																			●10TPP
							●10T													
MIG /MAG	T1 GYS AUTO	●	●			●	●													
	T3 GYS AUTO	●	●			●	●													
	AUTOPULSE 220-M1																			●
	AUTOPULSE 220-M3	●																		
	AUTOPULSE 320-T1					●														
	AUTOPULSE 320-T3	●				●														
VAS 821 005 - Pulse MIG Welder	●																			
VAS 821 00580 023	●																			
PLASMA	EASYCUT 40																			●
	CUTTER 25K/35KF		●																	
	CUTTER 30FV/45CT		●		●															
INDUC TION	GYSDUCTION AUTO	●																		●



# RANGE

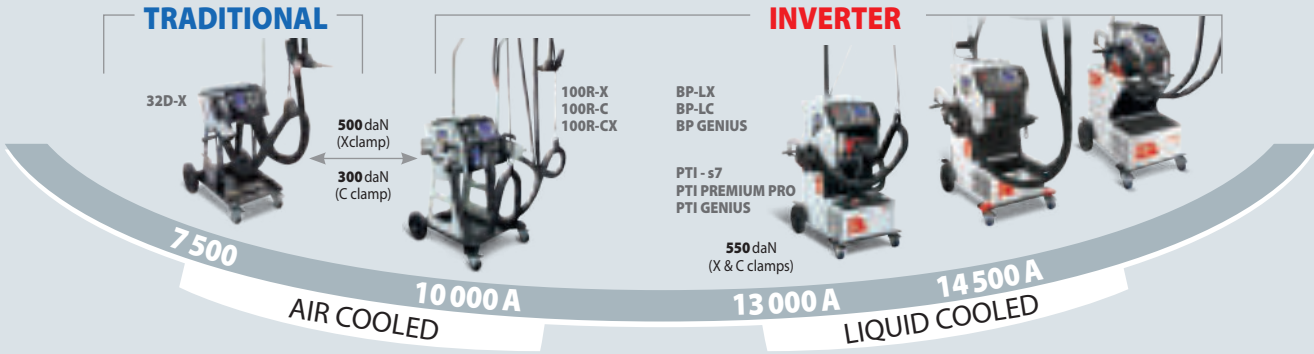

ENIUS		32 D	100 R	BP / BP GENIUS	PTI-s7	PTI PREMIUM PRO	PTI GENIUS			
Doux - Mild		•	•	•		•				
HLE/THLE - HSS/VHSS		X	•	•		•				
UHLE/BORE - UHSS/BORON		X	Difficult	•		•				
Nombre de points - Number of spots 10 spots/min		100	150	no limit	no limit					
		5	10	95	60	> 200				
Inverter Technology		—	•	•	•					
EMF Directive 2013/35/UE		—	—	<b>BODY PROTECT TECHNOLOGY</b>	•					
Système de refroidissement - Cooling system		<b>AIR</b>	<b>AIR</b>	<b>LIQUID</b>	<b>LIQUID</b>					
Régulation automatique - Automated regulation	I (A)	—	•	•	•					
	daN	—	•	•	•					
		irregular	<b>constant</b>	<b>constant</b>	<b>constant</b>					
<b>MODE AUTO</b>		—	—	<b>• (LC, LG)</b>	<b>•</b>					
Pince - Clamp	X	• (32DX)	• (100R-X)	• (B.P.LX)	—					
	C	—	• (100R-C)	• (B.P.LC, B.P.LG)	•	<b>G clamp</b>				
	X+C	—	• (100R-CX)	—	—					
Transformer Inside Clamp		—	—	—	•					
Cables (L)		2,5 m	2,5 m	2,5 m	4 or 6 m	6 m				
Includes gun		•	•	•	option					
Cadence de soudage maximale (points/min) - Max welding frequency (spots/min)		10	10			BP-LC : 10 - BP-LG : 20			10	20
		6	2	6	10	2	6	10	10	20
Fuse	400 V	32 A	32 A	40 A	50 A	32 A	40 A	50 A	20 A	25 A
	200/208-240 V	—	—	—	—	60 A	80 A	100 A	40 A	

**BP BODYPROTECT TECHNOLOGY**

2013/35/UE

UNIQUE ELECTRO-MAGNETIC FIELD PROTECTION by GYS

©BODY PROTECT is a proprietary GYS technology that minimises, electromagnetic fields created by the machine.

Compliant : Directive 2013/35/UE  
Certified by : Laboratory



**LA SOLUTION GLOBALE - THE GLOBAL SOLUTION**

**Other technologies**

10 < 25 cm (Norm : 3 cm max)

B1

25 < 35 cm (Norm : 30 cm max)

B2

35 cm (Norm : 20 cm max)

B3

35 cm (Norm : 20 cm max)

B4

**GYS BODYPROTECT TECHNOLOGY**

0 cm (Norm : 3 cm max)

B1

5 cm (Norm : 30 cm max)    4 cm (Norm : 30 cm max)

B2

0 cm (Norm : 20 cm max)

B3

0 cm (Norm : 20 cm max)

B4



GYSPOT

# SPOT WELDING

PORTASPOT 230

**6 300 A** 120 daN

Air cooled

230V  
022256

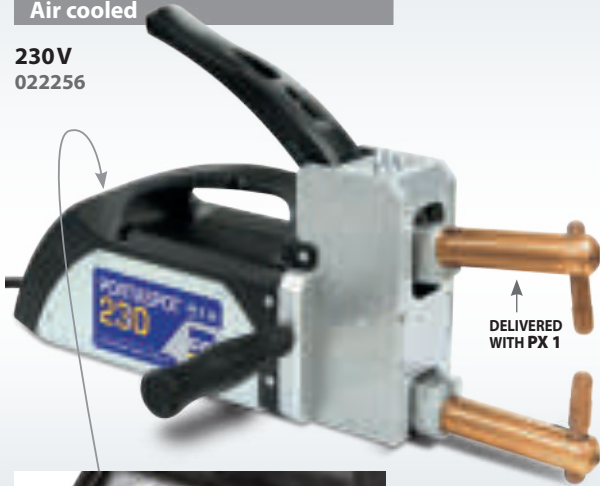

DELIVERED WITH PX 1



Youtube

ARMS Ø 23 mm

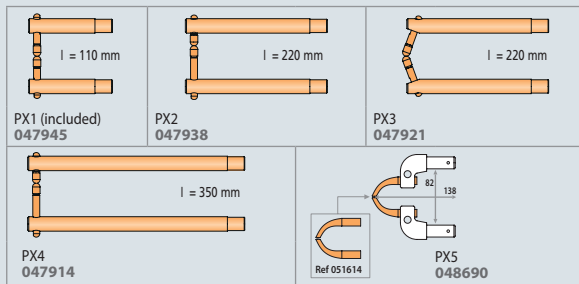

ELECTRODES



CAPS & ACCESSORIES



			RMS	MAX		Uo	Cable	100% CU		
	50/60 Hz	A	A	A	mm	V	↔ m ∅ mm <sup>2</sup>	OK	(no arm) cm	kg
1 x 230V	<b>16(D)</b>	<b>6 300</b>	8900	2+2	2,45	2,5	3x2,5 H05VVF	OK	36x29 x10	10

GYSPOT

**32D-X**

**7 500 A** 500 daN



Double pressure

Ø 8 mm

6 kg (included RX1)

Air cooled

2 x 400V

019881



INCLUDED

**32D-X** 019881

**100R-X** 019911

**100R-C** 019928

**100R-CX** 022317

	049291	049482+049802	050846	050440				051034
<b>32D-X</b>	■	■	■	■	■ Pro	■	■	■
<b>100R-X</b>	■	■	■	■	■ Pro	■	■	■
<b>100R-C</b>	■	■	■	■	■ Pro	■	■	—
<b>100R-CX</b>	■	■	■	■	■ Pro	■	■ x2	■



**GYSPOT  
100R-X**
**10 000 A** 500 daN

For mild steel, HSS, UHSS



- Double pressure
- Ø 8 mm
- 6 kg (included RX1)

Air cooled

**Traceability software**  
 Save spot welding configuration and export data

**3 x 400V**  
 019911

**GYSPOT  
100R-C**
**10 000 A** 300 daN

For mild steel, HSS, UHSS



- Large opening
- 360°
- Ø 8 mm
- 4 kg (included RC1)

Air cooled

**Traceability software**  
 Save spot welding configuration and export data

**3 x 400V**  
 019928

**GYSPOT  
100R-CX**
**10 000 A** 500 daN (X)  
 300 daN (C)

For mild steel, HSS, UHSS

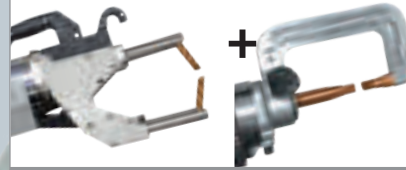

Air cooled

**Traceability software**  
 Save spot welding configuration and export data

**3 x 400V**  
 022317

**OPTIONS**

**050068**  
 x10 (x20: 052239)

x6 (x6: 049994)

x18 (x6: 049987)

x18 (x6: 049970)

**052260**  
 Housses de protection  
 - Protection cover  
 - Schutzhaube

**052253**  
 RC4  
 8 bar/120 daN,  
 for 32D-C, 100R-C  
 & 100R-CX

**048935**

x40 (x6: 049987)

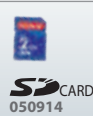
**051614**

**050914**

1 = 220 mm	1 = 220 mm	57 mm	124 mm	106 mm	124 mm
RX2 051041	RX3 051058	RC1 051065	RC2 051072	RC3 051089	
■	■				
■	■	■	■	■	■
—	—	■	■	■	■
—	■	■	■	■	■

 MADE IN FRANCE  CE 62135	 50/60 Hz	 A D curve	 Spots/min (max) 2.5+2.5	 RMS A	 MAX A	 mm	 U <sub>o</sub> V	Cables			100% CU	 cm	 kg	
								Air Cooled	↔ m	Ø mm <sup>2</sup>				
GYSPOT 32D.X	400V	32 (13 kVA)	6	7500	10500	3+3	1,2+3	11		2,2	200	OK	55 x 75 x 190	78
										2,5	150			
										8	3 x 6 H07RNF			
GYSPOT 100R.X GYSPOT 100R.C GYSPOT 100R.CX	3 x 400V	32 (22 kVA) 40 (28 kVA) 50 (35 kVA)	2 6 10	10000	—	2.5+2.5+2.5	1,5+3	16		2,5	200	OK	70 x 99 x 208	107 108 95.5
										2,5	150			
										8	4 x 6 H07RNF			



**GYSPOT**  
**BP-LX**

**13 000 A**  
550 daN

For mild steel, HSS, UHSS **Boron steel**

Double pressure  
 Ø10 mm  
6,5 kg (included X1)

**Liquid cooled**

**BP BODYPROTECT**  
Unique electro-magnetic field protection  
2013/35/UE by GYS

**Traceability software**  
Save spot welding configuration and export data

019652

**GYSPOT**  
**BP-LC-s7**

**13 000 A**  
550 daN

For mild steel, HSS, UHSS **Boron steel**

Double pressure  
 Ø10 mm  
6,5 kg (included C1)

**Liquid cooled**

**BP BODYPROTECT**  
Unique electro-magnetic field protection  
2013/35/UE by GYS

**Automatic C clamp**  
Energy Dynamic Control

**Traceability software**  
Save spot welding configuration and export data

020757

Included Support haute stabilité  
+High stability support  
Compatible gyro  
+

	019652	058804
Gyspot BP-LX		
Monopoint/Spot 049291	▪	▪
Spotter box pro (p.10) 050075	▪	▪
Inertia hammer 049482 + 049802	▪	▪
X1 050501	▪	▪
X4A (x2) + X4B + X4C + X2 020733		▪
Liquid cooling (10) 052246		(x3)

	020757	058798
Gyspot BP-LC-s7		
Monopoint/Spot 049291	▪	▪
Spotter box pro (p.10) 050075	▪	▪
Inertia hammer 049482 + 049802	▪	▪
Contact grease 050440	▪	▪
Caps remover 050846	▪	▪
Arm panel	▪	▪
C1 019140	▪	▪
C2 + C3 + C4 019126		▪
C6 022409		▪
Liquid cooling (10) 052246		(x3)

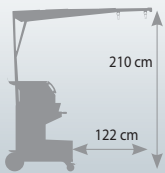

**OPTIONS**

050068  
x10 (x20: 052239) x18 (x6: 049987)  
x6 (x6: 049994) x18 (x6: 049970)

Caps type A box 048935 x40 (x6: 049987)

**NEW** Caps type F box 077119 x40 (x6: 049970)

SD CARD 050914

Liquide de refroidissement  
Cooling liquid  
Kühlmittel  
Enfriamiento líquido  
Refrigeração líquida

052246

Housse de protection - Protection cover - Schutzhaube

for BP & PTI 050853

Mandrels pour pistolets - Mandrels for gun - Pistole & Anschlußstücke, Zubehör

S1 < nov 2010 048171

S2 > nov 2010 048188

**OPTIONS BP-LC**

GYRO 360° for BP-LC 051737

10-14 kg



**GYSPOT  
PTI-s7**

**14 500 A**  
550 daN

For mild steel, HSS, UHSS **Boron steel**



- FUSE 20 A
- Double pressure
- Ø 10 mm
- 9,9 kg (included C1)

**TRANSFORMER INSIDE**

Liquid cooled

**Automatic C clamp**  
Energy Dynamic Control

Traceability software  
Save spot welding configuration  
and export data



020894

	6M 022195 <b>220V</b>	6M 020900 <b>400V</b>	4M 020894	4M 067998
Gyspot PTI-s7	■	■	■	■
Contact grease 050440	■	■	■	■
Caps remover 050846	■	■	■	■
Arm panel	■	■	■	■
C1 021402	■	■	■	■
C2 + C3 + C4 060821	■	■	■	■
C6 022409	■	■	■	■
Gyro 360° 051720	■	■	■	■
Complete gun kit 067318	■	■	■	■
Liquid cooling (10l) 052246	■	■	■	(x3)

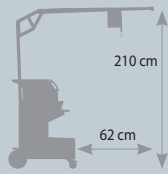

Very light  
**9,9 kg**

**NEW**

**CONVERT  
PTI S-7 > PTI PREMIUM  
PRO WITH G ARMS**

KIT RENOV PTI  
PREMIUM PRO  
220V 072367



400V 072541



C ARMS → G ARMS

**OPTION**



Complete gun kit  
067318



GYRO 360° for PTI  
051720



GYSPOT PTI

INVERTER

 MADE IN FRANCE  CE NORM. 62135	 50/60 Hz		 A D curve		Spots/min (max)	I <sub>RMS</sub>	U <sub>0</sub>	 mm		Cables			100 % CU	 cm	 kg
	3 x 400 V	32 (22 kVA) 40 (28 kVA) 50 (35 kVA)	2 6 10	13 000	V	2.5+2.5+2.5	1.5+3	2.5, liquid	2.5	8 m, 4x6 H07RNF	OK	65 x 80 x 205	150		
<b>GYSPOT B.P.LX</b>															
<b>GYSPOT B.P.LC-s7</b>															
<b>GYSPOT PTI-s7</b>	3 x 400 V	20 (14 kVA)	10	14 500	7.3			4 m, liquid 6 m, liquid		OPTION 067318 : 1.6 m, Ø 200 mm <sup>2</sup>	OK	65 x 80 x 230	92		
<b>GYSPOT PTI-s7 220 V</b>	3 x 200 208 220 240	40 (14-16 kVA)	10	12 500 13 000 14 500 14 500	6.5 6.7 7.4 7.7	2.5+2.5+2.5	1.5+3	4 m, liquid 6 m, liquid		8 m, 4xAWG8 (500W)	OK	65 x 80 x 230	98.5		

FOR GYSPOT 32D-X, 100R-X, BP-LX

**550 daN**

**6,5 kg** including X1

- DOUBLE PRESSURE**
- LIQUID COOLED**  
REFROIDISSEMENT LIQUIDE
- Ø 10 mm**



**X ARMS**  
Ø 25 mm



**X Arms - Caps Ø13 mm**

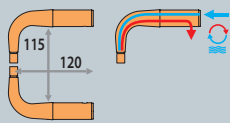

**X1 8 bar/550 daN**  
050501

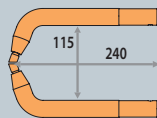

**X2 8 bar/400 daN**  
050518

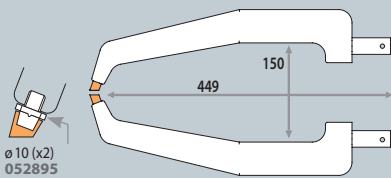

**X4 8 bar/120 daN**  
050532

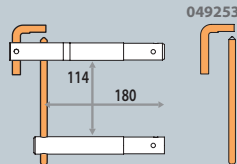

**X5 8 bar/200 daN**  
050549

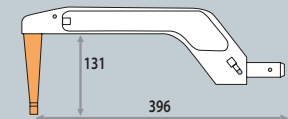

**X4A 8 bar/150 daN**  
020702

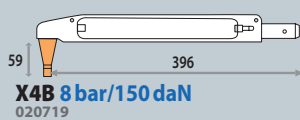

**X4B 8 bar/150 daN**  
020719



**X4C 8 bar/150 daN**  
020726

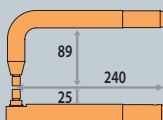

**X6 8 bar/400 daN**  
050587

**X4 (A, B & C) combinations**

260 mm X4A + X4A	190 mm X4A + X4B
120 mm X4B + X4B	150 mm X4A + X4C
40 mm X4C + X4C	80 mm X4B + X4C

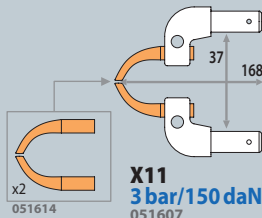

**X11 3 bar/150 daN**  
051607

**X ARMS PANELS**

**X4A (x2) + X5 + X2**  
022324

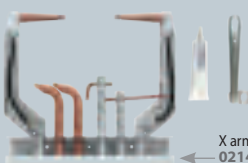

X arms support  
021471

**X4A (x2) + X4B + X4C + X2**  
020733



X arms support  
021471

**Remote control (BP)**



Digital screen control  
Change Mode & Parameters



X clamp control



C clamp control



**C ARMS PANELS**



C2  
+ C3  
+ C4  
060821



C2 +  
C3 +  
C6 +  
C12 +  
C9  
=  
061316

2 BOXES



C10 +  
C3 +  
C5 +  
C6 +  
C9  
=  
076495

**NEW**





**FOR GYSPOT BP-LC, PTI**

**550 daN**

**6,5 kg** including C1

- DOUBLE PRESSURE
- LIQUID COOLED  
REFROIDISSEMENT LIQUIDE
- Ø 10 mm



MADE IN FRANCE



**550 daN**

**Transformer inside**

**9,9 kg** including C1

- DOUBLE PRESSURE
- AIR COOLED + LIQUID COOLED  
DOUBLE REFROIDISSEMENT AIR + LIQUID
- Ø 10 mm

**C Arms - Caps Ø13 mm**

**Classic arms**



**CLASSIC FINISH**

**Bras isolés - Isolated arms - Isolierte Bügel**

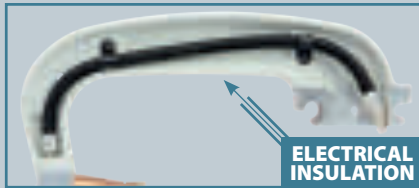

**ELECTRICAL INSULATION**

Arm lock pin  
062405

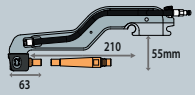
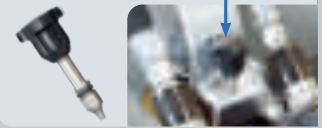

**C2 8 bar/550 daN**

022386

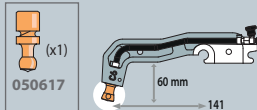

**C6 8 bar/300 daN**

022409

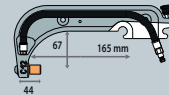

**C12 8 bar/550 daN**

022997

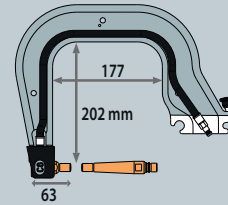

**C8 8 bar/550 daN**

021440

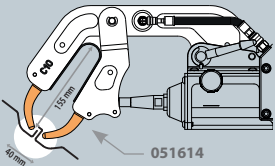

**C10 4 bar/150 daN**

051638

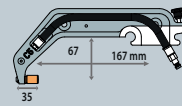

**C5 8 bar/550 daN**

022393

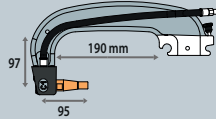

**C1 8 bar/550 daN**

021402

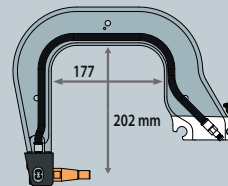

**C3 8 bar/550 daN**

021419

**X Arms - Caps Ø13 mm**

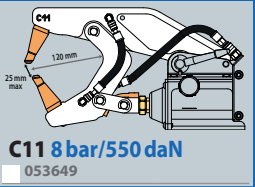

**C11 8 bar/550 daN**

053649

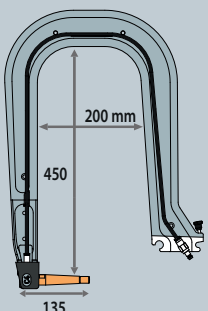

**C4 8 bar/550 daN**

021426

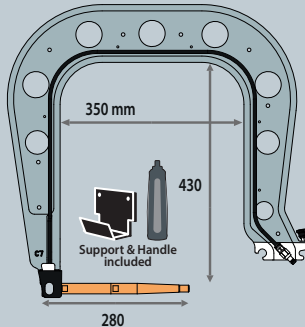

**C7 8 bar/550 daN**

021433

Option for C7

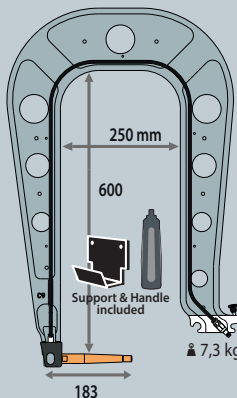

**C9 8 bar/550 daN**

020078

Option for C9 & C14

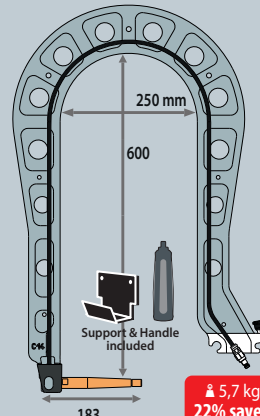
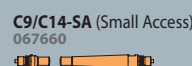

**C14 8 bar/400 daN**

023543



GYSPOT

# SPOT WELDING

## G GENIUS

**G**  
ARMS  
p.60

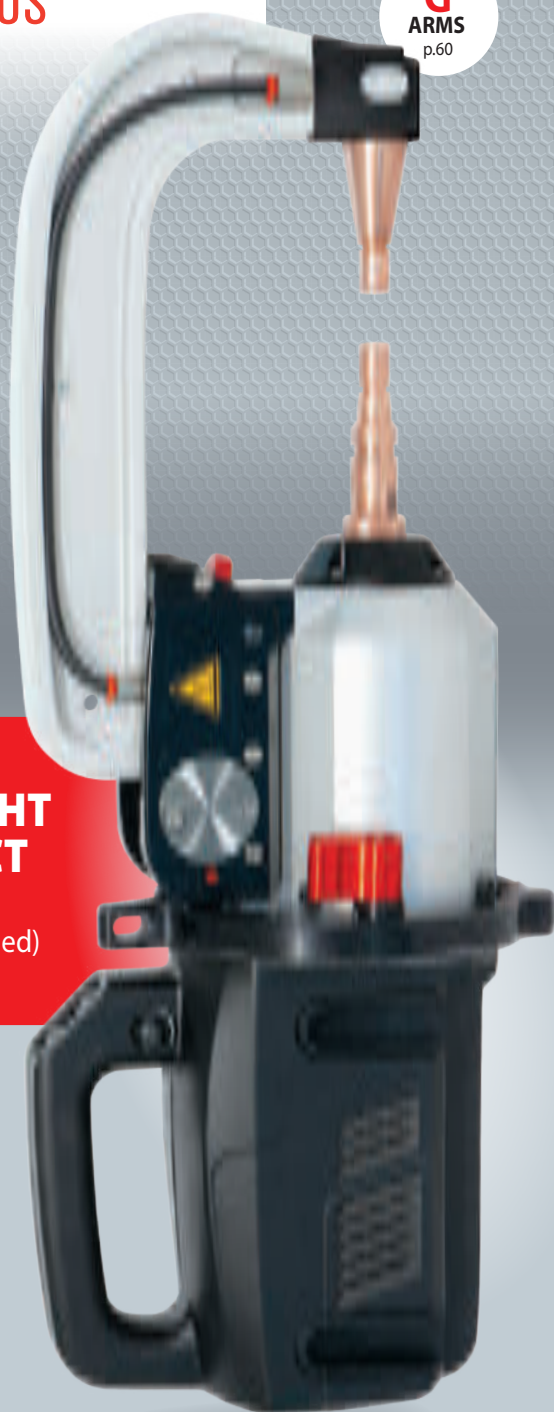

MADE IN FRANCE

### ULTRA LIGHT & COMPACT

6.5 kg  
(Gyro & G1 included)

550 daN

LIQUID COOLED  
REFROIDISSEMENT  
LIQUIDE

Ø 10 mm

6.5 kg  
(Gyro & G1 included)



Youtube

### FAST OPEN XL

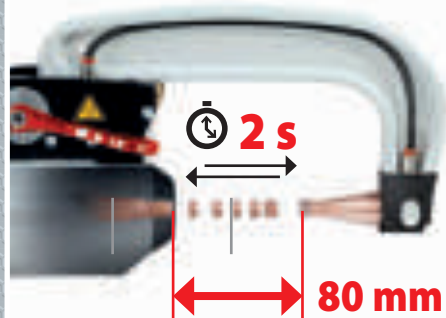

### EASY



### GYRO INTEGRATED

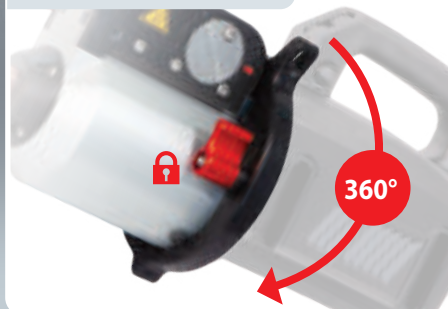

### PERFECT ELECTRICAL CONNECTION



### AUTO



### OPTIONS



Caps type A box  
048935

x40  
(x6 : 049987)

Caps type F box  
077119

x40  
(x6 : 049970)

x20  
(x6 : 049987)

x6  
(x6 : 049970)

x2  
(x1 : 050617)

073449



SD  
SD CARD  
050914

Liquide de  
refroidissement  
Cooling liquid  
Kühlmittel  
Enfriamiento  
líquido  
Refrigeração  
líquida

052246

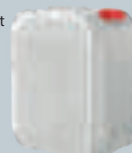

Housse de  
protection  
- Protection  
cover  
- Schutzhaube

for BP & PTI  
050853



10-14 kg  
059696



GVSPOT

# BP GENIUS

**13 000 A**  
550 daN

For mild steel, HSS, UHSS

Boron steel



**BODYPROTECT**

Unique electro-magnetic field protection by GYS

**Traceability software**  
Save spot welding configuration and export data



023451



	023550	023451	023499
Gyspot BP GENIUS	<b>220V</b>	<b>400V</b>	
Monopoint/Spot 049291	▪	▪	▪
Spotter box pro (p.10) 050075	▪	▪	▪
Inertia hammer 049482 + 049802	▪	▪	▪
Caps remover 050846	▪	▪	▪
Arm support	▪	▪	▪
G1 022768	▪	▪	▪
G2 + G3 + G4 022898			▪
Liquid cooling (10) 052246			(x3)



55

GYSPOT BP GENIUS

LIQUID COOLED

 MADE IN FRANCE		 50/60 Hz	 A D curve	 Spots/min (max) 2.5+2.5	 I <sub>RMS</sub> A	 U <sub>o</sub> V	 mm		Cables			 100 % CU	 cm	 kg	
<b>GYSPOT BP GENIUS 220 V</b>		3 x	200	<b>60</b> (21-25 kVA) <b>80</b> (28-33 kVA) <b>100</b> (35-41 kVA)	<b>2</b> <b>6</b> <b>10</b>	<b>10500</b> <b>11000</b> <b>12000</b> <b>12500</b>	15 15,5 17 18	2.5+2.5+2.5	1,5 + 3	2,5 m, Ø 200 mm <sup>2</sup> , Liquid	2,5 m, Ø 150 mm <sup>2</sup> air	8 m 4x16 mm <sup>2</sup> (6AWG) 500W	OK	65 x 80 x 205	160
			220												
			240												
<b>GYSPOT BP GENIUS 400V</b>		3 x 400 V	<b>32</b> (22 kVA) <b>40</b> (28 kVA) <b>50</b> (35 kVA)	<b>2</b> <b>6</b> <b>10</b>	<b>13000</b>	16	2.5+2.5+2.5	1,5 + 3	2,5 m, Ø 200 mm <sup>2</sup> , Liquid	2,5 m, Ø 150 mm <sup>2</sup> air	8 m 4x6 mm <sup>2</sup> H07RNF	OK	65 x 80 x 205	160	



GYSPOT

# SPOT WELDING

**G**  
ARMS  
p.60

**NEW**



MADE IN FRANCE

**FULL  
ERGONOMIC**

**10.3 kg**  
(Gyro & G1 included)

**550 daN**



LIQUID COOLED  
REFROIDISSEMENT  
LIQUIDE

Ø 10 mm

**10.3 kg**  
(Gyro & G1  
included)



**TRANSFORMER INSIDE**

**GYRO INCLUDED**



**PERFECT ELECTRICAL CONNECTION**

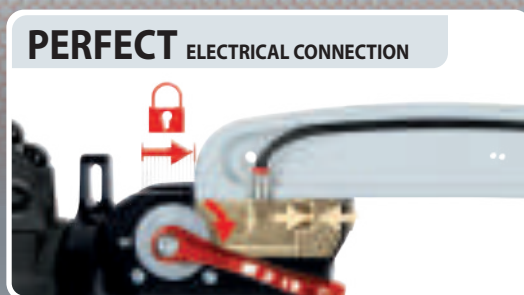

**AUTO**



**XL Balancer**

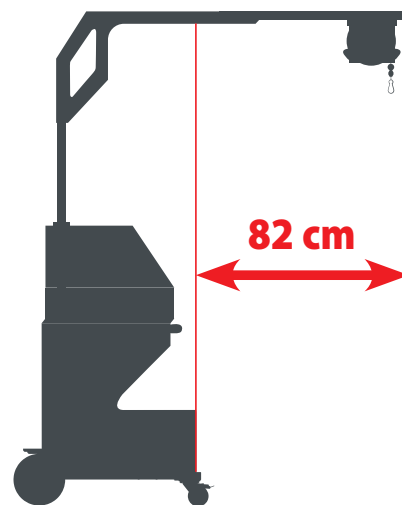

**Ergonomy & Security**



**EASY  
HANDLE**



**LOCKING  
SYSTEM**



## OPTIONS



Caps type A box  
048935

x40  
(x6: 049987)

**NEW**

Caps type F box  
077119

x40  
(x6: 049970)

x20  
(x6: 049987) 073449

x6  
(x6: 049970)

x2  
(x1: 050617)



SD CARD  
050914

Liquide de refroidissement  
- Cooling liquid - Kühlmittel  
- Enfriamento líquido -  
Refrigeración líquida



052246



**GYSPT PTI PREMIUM PRO**

**14500 A**

550 daN

For mild steel, HSS, UHSS

**Boron steel**



- FUSE 20 A
- Double pressure
- Ø 10 mm
- 10,3 kg (included G1)

**TRANSFORMER INSIDE**

Liquid cooled

**EDC** Automatic G clamp  
Energy Dynamic Control

Traceability software  
Save spot welding configuration and export data

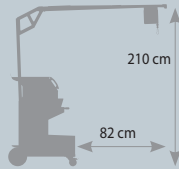

**NEW**



G Arms p.60

	6M	
	072206 072183	
	<b>220V</b>	<b>400V</b>
GYSPT INVERTER PTI PREMIUM PRO		
	▪	▪
Caps remover 050846		
	▪	▪
Arm panel		
	▪	▪
G1 022768		



**OPTIONS**

**G11**  
for PTI PREMIUM PRO only

**NEW**

071766

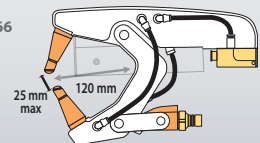

Kit gun 067226



300 mm<sup>2</sup>  
1.8 m

300 mm<sup>2</sup>  
1m

MADE IN FRANCE CE NORM. 62135	50/60 Hz		A D curve	Spots/min (max) 2.5+2.5	I <sub>RMS</sub> A	U <sub>0</sub> V	mm		Cables			100% CU	cm	kg
	3 x	200 208 220 240	30 (10-12 kVA) 40 (14-16 kVA) 50 (17-21 kVA)	10	12500 13000 14500 14500	6.6 6.9 7.3 7.9						OK	65 x 100 x 230	92
<b>GYSPT PTI PREMIUM PRO 220V</b> 	3 x 400V	25 (14 kVA)	10	14500	7.3							OK	65 x 100 x 230	92
<b>GYSPT PTI PREMIUM PRO 400V</b>											OK	65 x 100 x 230	92	



**FAST OPEN XL**

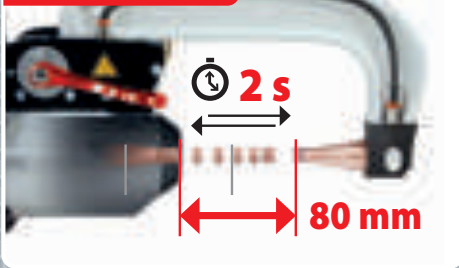

**GYRO INTEGRATED**



**PERFECT ELECTRICAL CONNECTION**



**AUTO**



MADE IN FRANCE

**G**  
ARMS  
p.60

550 daN

LIQUID COOLED  
REFROIDISSEMENT  
LIQUIDE

Ø 10 mm

11.3 kg  
(Gyro & G1 included)

**TRANSFORMER  
INSIDE**



Potence électrique -  
Motorised cable support  
- Elektrisch verstellbarer  
Kabelsupport

**NEW** DESIGN

Avec contrôle de  
commande - with  
control command



**OPTIONS**

**Caps type A box** 048935 x40 (x6: 049987)

**Caps type F box** 077119 x40 (x6: 049970)

x20 (x6: 049987)

x6 (x6: 049970)

x2 (x1: 050617)

073449

SD CARD 050914

2

Kit WIFI  
Compatibility:  
Gyspot  
Inverter  
PTI-GENIUS

070691

Liquide de refroidissement  
- Cooling liquid - Kühlmittel  
- Enfriamento líquido  
Refrigeración líquida

052246

Housse de protection  
- Protection cover  
- Schutzhaube  
for BP & PTI

050853

GYSPOT

# PTI GENIUS

## 14 500 A

550 daN

For mild steel, HSS, UHSS

Boron steel

**TRANSFORMER INSIDE**

**Traceability software**  
Save spot welding configuration and export data



	024854	024878	068001	024892
Gyspot PTI-GENIUS	<b>220V</b>	<b>400V</b>		<b>480V</b>
Caps remover 050846	▪	▪	▪	▪
Arm support	▪	▪	▪	▪
G1 022768	▪	▪	▪	▪
G2 + G3 + G4 022898			▪	
Kit gun 067226			▪	
Liquid cooling (10l) 052246			(x3)	

### Ergonomic

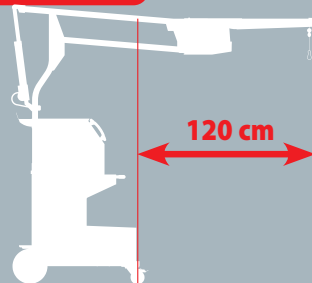

Included  
Cable support  
**ULTRA  
RESISTANT**



**ELECTRIC  
MOTOR**

Control  
Commande

Boîte de rangement pour électrodes - Electrode storage box

6 m

**Grande stabilité  
- High stability**

### OPTIONS

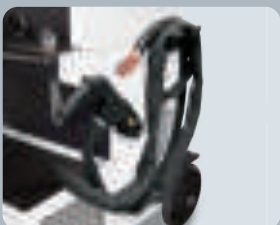

 MADE IN FRANCE	 CE NORMA 62135	 50/60 Hz	 A D curve	 Spots/min (max) 2.5+2.5	   RMS A	 Uo V	 mm		 Cables		 cm	 kg
<b>GYSPOT PTI GENIUS 220 V</b> 	3 x	200	50 (17-21 kVA)	20	12 500	6.6	2.5+2.5+2.5	1,5 + 3	6 m, Liquid	8 m 4xAWG8 (500W)	71 x 90 x 200	100
		220				6.9						
		240				7.3						
<b>GYSPOT PTI GENIUS 400V</b>	3 x 400V	25 (17 kVA)	20	14 500	7	2.5+2.5+2.5	1,5 + 3	6 m, Liquid	8 m 4x4 mm <sup>2</sup> H07RNF	71 x 90 x 200	100	
		20 (17 kVA)			7							
<b>GYSPOT PTI GENIUS 480V</b>	3 x 480V	20 (17 kVA)	20	14 500	7	2.5+2.5+2.5	1,5 + 3	6 m, Liquid	8 m 4xAWG12 (500W)	71 x 90 x 200	100	





# FOR GYSPOT BP GENIUS, PTI PREMIUM PRO & PTI GENIUS

G Arms - Caps Ø13 mm

Bras isolés - Isolated arms - Isolierte Bügel

Reversible  
for G1, G3, G4, G5,  
G8, G10 & G12

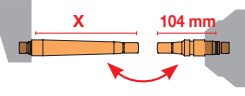

Kit de maintenance connecteurs pince G - Connectors maintenance kit for G clamp 067295

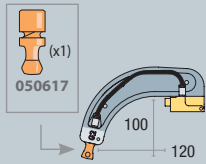

**G2**  
8 bar/300 daN  
022775

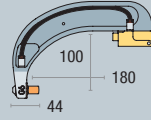

**G6**  
8 bar/550 daN  
022812

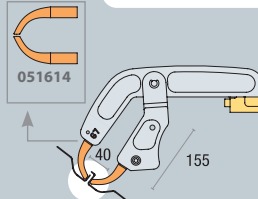

**G7**  
4 bar/150 daN  
022829

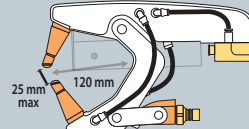

**G11**  
for PTI PREMIUM PRO only  
071766



Protections for G clamp & arms  
067288

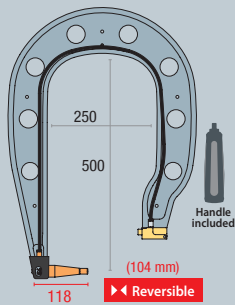

**G4**  
8 bar/550 daN  
022799

Option for G4

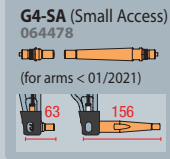

**G4-SA (Small Access)**  
064478  
(for arms < 01/2021)

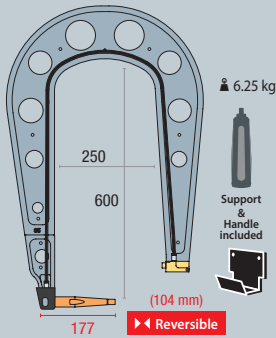

**G5**  
8 bar/550 daN  
022805

Option for G5

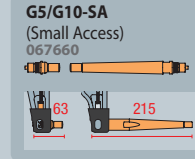

**G5/G10-SA (Small Access)**  
067660

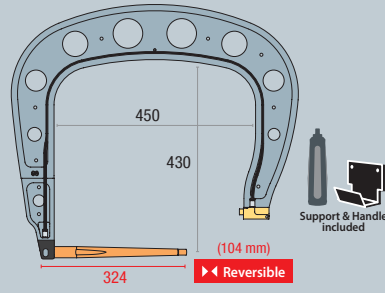

**G8**  
8 bar/550 daN  
022836

Option for G8

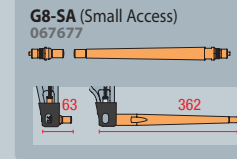

**G8-SA (Small Access)**  
067677

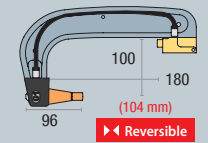

**G1**  
8 bar/550 daN  
022768

Option for G1 & G3

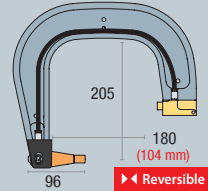

**G3**  
8 bar/550 daN  
022782

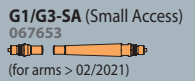

**G1/G3-SA (Small Access)**  
067653  
(for arms > 02/2021)

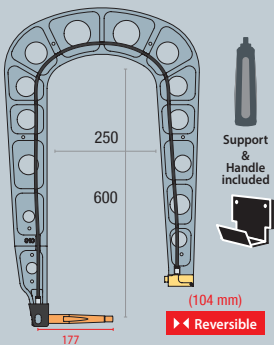

**G10**  
8 bar/400 daN  
067165

Option for G10 & G12

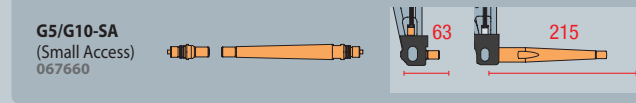

**G5/G10-SA (Small Access)**  
067660

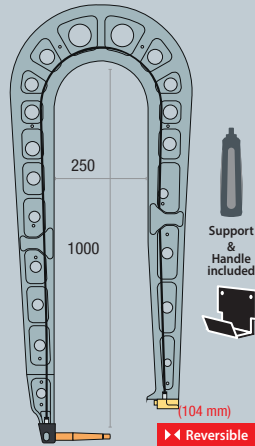

**G12**  
8 bar/300 daN  
075238

Option SD card  
050914

Option PCB  
97449C

90284 + 55121

**G > X**  
UNIQUE SYSTEM

BREVETÉ PATENTÉ  
AUTOMATIC WELDING  
FOR X1, X2 & X6

Youtube



**G9 | 8 bar/550 daN**  
not for PTI PREMIUM PRO

**G9 with X1 Included**  
022881

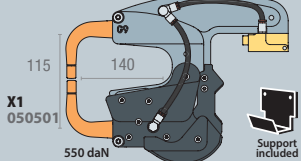

Option for G9  
**X2**  
050518

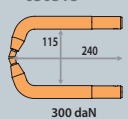

**G9 with X6 Included**  
072275

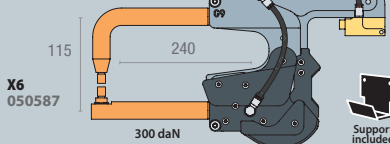

**G ARMS PANELS**

- G2
- + ■ G3
- + ■ G4
- 022898

- G2
- + ■ G3
- + ■ G5
- 063297

**KIT SMALL ACCESS GENIUS**

077072

**NEW**

for PTI GENIUS & PTI PREMIUM PRO

- G1/G3-SA (Small Access) + ■ G5/G10/C9/C14-SA (Small Access)
- + ■ G4-SA (Small Access) + ■ G8-SA (Small Access)





## CONSOMMABLES X/C/G - X/C/G Consumables

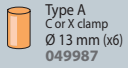

Type A  
Cor X clamp  
Ø 13 mm (x6)  
049987

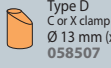

Type D  
Cor X clamp  
Ø 13 mm (x10)  
058507

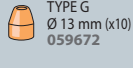

TYPE G  
Ø 13 mm (x10)  
059672



Caps type A box  
048935  
x40  
(x6: 049987)

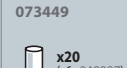

073449  
x20  
(x6: 049987)



Caps type F box  
077119  
x6  
(x6: 049970)  
x2  
(x1: 050617)

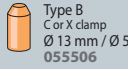

Type B  
Cor X clamp  
Ø 13 mm / Ø 5 mm (x6)  
055506

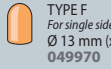

TYPE F  
For single sided gun  
Ø 13 mm (x6)  
049970

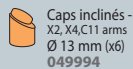

Caps inclinés - Beveled  
x2, X4, C11 arms  
Ø 13 mm (x6)  
049994

NEW

Caps type F box  
077119  
x40  
(x6: 049970)



Graisse contact  
Contact grease  
050440



Caps  
remover  
050846



Europax  
anti-corrosion  
052758



Monopoint / Spot  
049291



050068

x10  
(x20: 052239)  
x6  
(x6: 049994)

x18  
(x6: 049987)  
x18  
(x6: 049970)

## AFFUTEUR DE CAPS PNEUMATIQUE - Pneumatic cap grinder

061484



Lame - Blade  
061491



Type A caps

## AFFUTEUR DE CAPS - Cap grinder

Lame - Blade  
052857

048966



Optimal speed :  
400-800 rpm



## BANC DE TRACTION ARRACHE TÔLE

- Steel sheet traction bench - Blech-Zugbank zur Festigkeitsprüfung

052420



052321  
(included)

## VALISE TEST SOUDURE HLE / THLE

- Weld test kit - Schweißtestkit im Hartschalenkoffer

050433



Barre d'arrache / Traction bar  
+ Acier doux / Mild steel 0.65 (x25) + 1.0 (x25)  
+ Acier HSLA 360 - HLE 0.8 (x25) + 1.5 (x25)  
+ Acier DP600 - THLE/UHLE 1.0 (x25)  
+ Acier FB560 - THLE/UHLE 2.5 (x25)

## PROTECTION ANTI-ARC 12 V

- Anti-arc protection 12V - Lichtbogenschutz 12V - Protección anti-arco 12V

041318



## GYRO 360°

for BPLC/BPLCX  
051737



10-14 kg

for PTI  
051720

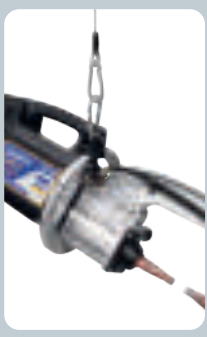

## ÉCHANTILLONS DE TÔLES

- Sheets set

Acier standard /  
Standard steel  
0,8 (x65) + 1 (x55) + 1,5  
(x35) + 2 (x25)  
+ Alu  
1 (x45) + 1,5 (x30) + 2 (x20)

055841



## CAPTEUR D'EFFORT

- Electrode force sensor

052314



## KIT DE PURGE RÉSERVOIR

- Tank draining kit - Kit zur Tankentleerung

058286



for GYSPOT  
BPLC-s7 /  
BPLCX-s7 /  
PTI-s7

## CARTE MÉMOIRE SD

- SD memory card



SD CARD  
050914

## KIT WIFI

for Gyspot  
Inverter  
PTI GENIUS

070691



## HOUSSE DE PROTECTION

- Protection cover - Schutzhaube

for BP  
& PTI

050853



## LIQUIDE DE REFRIGÉRISSMENT

- Cooling liquid -  
Kühlmittel  
- Enfriamento líquido -  
Refrigeração líquida

052246







GYPRESS

# RIVETING

PNEUMATIC HYDRAULIC



Youtube



## BRAS DE RIVETAGE - RIVETING ARMS - STANZIETBÜGEL

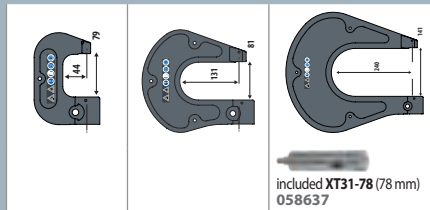

included XT31-78 (78 mm)  
058637

	HR110	HR210	HR310 8T PP/10T/10T PP
	063310	063327	063334
GYPRESS 8T	✓	✓	—
GYPRESS 10T	✓	✓	✓
GYPRESS 8T PUSH PULL	✓	✓	✓
GYPRESS PREMIUM 10T PUSH PULL	✓	✓	✓
GYPRESS 10T PUSH PULL	✓	✓	✓
GYPRESS 10T CONNECT	✓	✓	✓

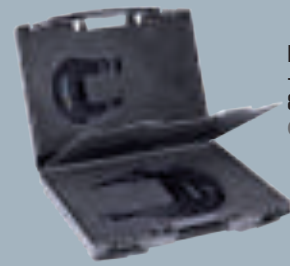

KIT HR210  
+ HR310  
8T PP/10T/10T PP  
064089

XT31-40  
Rallonges bras HR310  
pour point milieu  
- HR310 arm extension  
for middle point

Compatible  
8T PP/10T/10T PP  
x2

066335

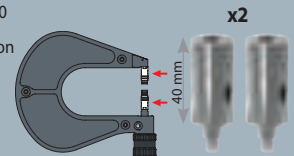

## OPTIONS

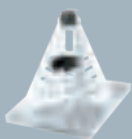

Support Riveteuse pour changements  
d'accessoires (bras & matrice)  
- Riveting machine support for changing  
accessories (arms & dies)  
- Supportständer  
↳ 28 x 40 x 21,5 cm

054158



Chariot-Trolley  
↳ 79 x 81 x 51 cm  
↳ 80 x 15 x 123 cm  
44 kg

054233



Chariot + Support  
Trolley + Support  
↳ 51 x 122 x 74 cm

055391



Capteur d'effort  
062115



Hydraulic body wrenches  
(x2)  
067325



Serre-tôles - Temporary-fasteners manual  
mounting

(x10)  
Ø 2,4 mm  
069664



(x10)  
Ø 4,0 mm  
069671



(x10)  
Ø 4,8 mm  
069688



(x10)  
Ø 6,4 mm  
069695



**GYSPRESS 10T**

6.5 bar | 100 kN

**10t**

063303

**US version**  
070653

 Pressure gauge  
Psi > Kn

 Levier de décharge  
- Discharge lever - Auslösehebel

 Contrôle de la vitesse - Speed control - Regelung  
Werkzeuggeschwindigkeit

 Contrôle de la pression  
- Pressure control - Druckregelung

**UNIQUE**  
**100%**   
**No air inclusion**  
maintenance free, no oil refill

**GYSPRESS 10T COMPLETE PACKS**

	 <b>HR110</b> 063310  <b>XT11.21</b> Extension for HR110 & HR210 058644  Standard 10T tool box 053694  6 x 50 rivets RAP - Nieten SPR 048706  Strap-Sangle-Gurt  HR arm locker  Poignée-Handle-Griff	 <b>HR210 + HR310</b> 064089	 50kN adapter 064867  Pulling adapter kit 066076	 Trolley+support 055391
<b>GYSPRESS 10T</b> 063303 070653	✓			
<b>GYSPRESS 10T pack 1</b> 066441		✓		
<b>GYSPRESS 10T pack 2</b> 066458			✓	
<b>GYSPRESS 10T pack 3</b> 064744		✓		✓

 MADE IN FRANCE	AIR BAR	PRESSURE CONTROL	SPEED CONTROL	↕	⬇️	↕	⬇️
				cm	kg	cm	kg
<b>GYSPRESS 10T</b>	6.5 bar = 10 t (maxi 10 bar)	0 > 6.5 bar	+ ↔ -	39.5 x 180	6.2 (HR110 included)	58 x 48 x 15	11.8

# GYPRESS 10T PUSH PULL

6.5 bar

100 kN

**10t**

063853

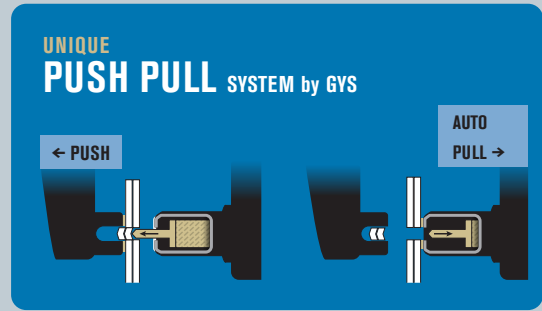
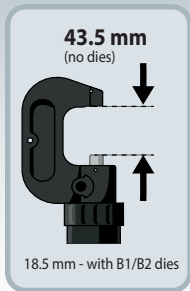

UNIQUE  
**100%**

**No air inclusion**  
maintenance free, no oil refill

## GYPRESS 10T PUSH PULL COMPLETE PACKS

	<p>HR110 063310</p> <p>XT11.21 - Extension for HR110 &amp; HR210 058644</p> <p>Standard 10T tool box 053694</p> <p>6x50 rivets RAP - Nieten SPR 048706</p> <p>Strap-Sangle-Gurt</p> <p>HR arm locker</p> <p>Poignée-Handle-Griff</p>	<p>HR210 + HR310 064089</p>	<p>50kN adapter 064867</p> <p>Pulling adapter kit 066076</p>	<p>Trolley+support 055391</p>
<b>GYPRESS 10T PUSH PULL</b> 063853	✓			
<b>GYPRESS 10T PP pack 1</b> 066465		✓		
<b>GYPRESS 10T PP pack 2</b> 066472			✓	
<b>GYPRESS 10T PP pack 3</b> 065789		✓		✓

<p>MADE IN FRANCE</p>	AIR BAR	PRESSURE CONTROL	SPEED CONTROL				
				cm	kg	cm	kg
<b>GYPRESS 10T PUSH PULL</b>	6.5 bar = 10 t (maxi 10 bar)	0 > 6.5 bar		39.5 x 180	6.7 (HR110 included)	58 x 48 x 15	12.5



**GYSPRESS PREMIUM  
10T PUSH PULL**

6.5 bar | 100 kN

**10t**

077065



**LARGE OPENING**

**48.5 mm**  
(no dies)

**MORE ACCESS**

23.5 mm - with B1/B2 dies

**NEW**

**US version**  
070660

Pressure gauge  
Psi > Kn

**HYDRAULIC SYSTEM**  
fermé - closed - geschlossen

**UNIQUE 100%**

**No air inclusion**  
maintenance free, no oil refill

**UNIQUE PUSH PULL SYSTEM** by GYS

**AUTO or MANUAL**

**← PUSH**      **PULL →**

**ERGONOMIC WITH QUICK SELECTION**

**WORK FASTER**

Sélection Push/Pull  
- Push/Pull selection

**MANUAL PULL MODE**

Sélection Manuel/  
Automatique  
- Manual/Automatic  
selection

**OPENING CONTROL**

Contrôle de la pression  
- Pressure control  
- Druckregelung

Contrôle de la vitesse -  
Speed control  
- Regelung Werk-  
zeuggeschwindigkeit

**GYSPRESS 10T PREMIUM PUSH PULL COMPLETE PACK**

	<b>HR110</b> 063310	<b>XT11.21</b> - Extension for HR110 & HR210 058644	Standard 10T tool box 053694	6 x 50 rivets RAP - Nieten SPR 048706	Strap-Sangle-Gurt	HR arm locker	Poignée-Handle-Griff
<b>GYSPRESS PREMIUM 10T PUSH PULL</b> 077065 070660							

 MADE IN FRANCE	AIR BAR	PRESSURE CONTROL	SPEED CONTROL					
				cm	kg	cm	kg	
<b>GYSPRESS 10T PREMIUM PUSH PULL</b>	6.5 bar = 10 t (maxi 10 bar)	0 > 6.5 bar		39.5 x 180	6.7 (HR110 included)	58 x 48 x 15	?	



# SYNERGIC RIVETING WORKSTATION

PNEUMATIC HYDRAULIC



UNIQUE 100% No air inclusion maintenance free, no oil refill

## ▶ ACCESSIBILITY

10 languages

- FR
- ES
- CN
- GB
- CZ
- JP
- DE
- NL
- IT
- RU



Main panel

Setup instructions

Results



## ▶ 3 MODES

- MANUAL
- SYNERGIC
- CAR MANUFACTURERS

## ▶ CAR MANUFACTURERS COMPATIBILITY

- ✓ VW GROUP
- ✓ MERCEDES-BENZ
- ✓ BMW
- ✓ TESLA
- ✓ FERRARI
- ✓ FORD
- ✓ JAGUAR / LAND ROVER
- ✓ GM

## ▶ CONNECTIVITY

### TRACEABILITY

History data export

Date	OK	Time	Value	Act
Riveting1	9.80N	10:00:10	OK	1
Riveting2	9.80N	10:02:45	OK	1
Riveting3	9.80N	10:05:10	OK	1
Riveting4	9.80N	10:07:45	OK	1
Riveting5	10.00N	10:10:10	OK	1

### SOFTWARE UPDATE

Gyspress evolutions



**UNIQUE  
PUSH  
PULL  
SYSTEM by GYS**

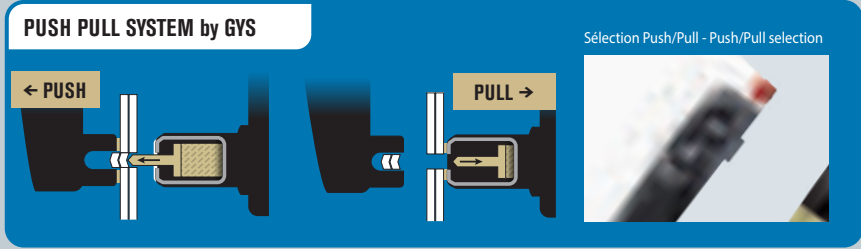

Gyspress support



Arms support



**REGULATED  
PRESSURE  
CONTROL**

**POWER  
10t**

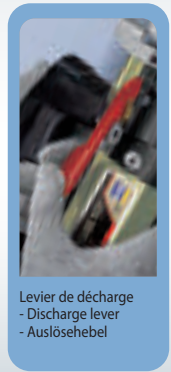

**WORKSTATION  
GYSPP 10T PP CONTROL**

6.5 bar	100 kN
<b>10t</b>	

063860

Included

-  **HR110**  
063310
-  **XT11.21** - Extension  
for HR110 & HR210  
058644
-  **Standard 10T PushPull tool box**  
058361
-  **6 x 50 rivets RAP -  
Nieten SPR**  
048706
-  **Strap-Sangle-Gurt**
-  **HR arm locker**
-  **Poignée-Handle-  
Griff**

**OPTIONS**

**Capteur  
d'effort**  
10T PP CONTROL  
071759



Youtube



**Hydraulic body wrenches**  
for GYSPPRESS 10T, 10T  
PushPull, 10T PP CONTROL  
(x2)  
067325

 MADE IN FRANCE		AIR BAR	PRESSURE CONTROL	SPEED CONTROL	 cm	 kg
		230V	6.5 bar = 10 t (maxi 10 bar)	0 > 6.5 bar		
<b>WORKSTATION GYSPP 10T PP CONTROL</b>						





## ADAPTATEURS POUR RIVETS AVEUGLES - BLIND RIVET ADAPTERS

GYPRESS

Adaptators

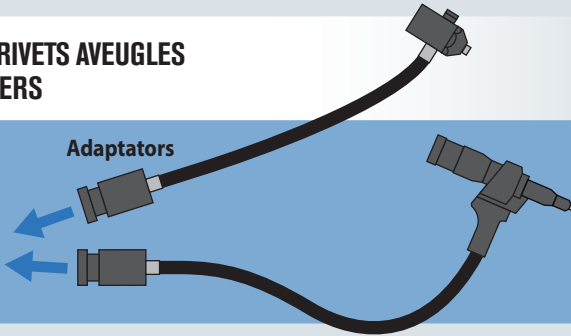
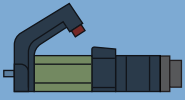

### Compatibility

GYPRESS 10T  
GYPRESS 10T PUSH PULL  
GYPRESS 10T PUSH PULL PREMIUM  
GYPRESS 10T CONNECT



## ADAPTATEUR 24 KN POUR RIVETS AVEUGLES - Blind rivet adapter 24 kN - Blindnietadapter 24 kN

HIGH  
ACCESSIBILITY



SPECIFIC  
STORAGE



**24 kN STANDARD** 600 mm  
063822

Pour rivets POP - For BLIND rivets - Für Blindniet

Acier / Steel : Ø 4.0 → 6.4  
Alu: Ø 4.0 → 7.8



Ø 4.5 max

360°

Ø 37mm

104 mm

INCLUDED

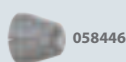

for standard rivets:

Ø 3.2 x 1 059221  
Ø 3.6 x 1 059238

Ø 4.0 x 1 059245  
Ø 4.5 x 1 059252

**24 kN COMPACT** 600 mm  
077164

Pour rivets POP - For BLIND rivets - Für Blindniet

Acier / Steel : Ø 6.4  
Alu: Ø 6.4 → 7.8



COMPACT  
HEAD



**NEW**  
11 / 2022



Ø 5.2 max

360°

Ø 32.5mm

89 mm

INCLUDED



for standard rivets:

Ø 4.5 x 1 059252  
Ø 5.2 x 1 059252

### PERFECT COMBO WITH ARC PULL

SPÉCIAL ARRACHAGE DE RIVETS  
Special tearing rivets - Spezial-  
Zugnieten

①

Stainless steel rod  
welding  
with GYSPOT Arc Pull  
350/700

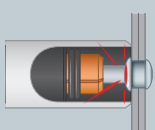

②

Extraction of self  
piercing rivet  
with GYPRESS  
adapters

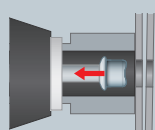

### OPTION FOR GYSPOT ARC PULL (details p.17)

for GYSPOT ARCPULL 350

#### ARC PULL RIVET BOX1 350 - 24kN

064584

Tige inox - Stainless steel nail Ø 4 x 50 mm 064607	Canon pour pose de tige inox - Barrel for stainless steel nail welding 059641	Support porte- goujon - Mandrel support 059634	Buse + patin - Nozzle + pad 059641	mandrel Ø4mm 049000	Buse d'extraction 24kN Ø 4 064683
×100	×1	×1	×1	×1	×1



**50 kN** 1 m  
064867

4.0 kg

Réglage de la course de traction - Stroke adjustment  
0 → 25 mm

Pour rivets POP - For BLIND rivets - Für Blindniet

Acier / Steel : Ø 4.0 → 6.4  
Alu: Ø 4.0 → 7.8

INCLUDED

Kit Standard



included  
058446

+ Complete kit 065987

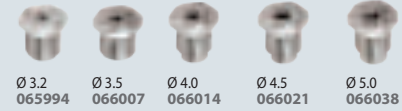

Ø 3.2 065994    Ø 3.5 066007    Ø 4.0 066014    Ø 4.5 066021    Ø 5.0 066038

OPTIONS

Acier / Steel : Ø 4.0 → 6.4  
Alu: Ø 4.0 → 7.8

Extension 160 mm - 160 mm extension - Verlängerung 160 mm  
066144



included  
058446

160 mm

Ø 8.0 → 9.8

Kit Rivets Ø8.0/9.8mm - Ø8.0/9.8mm noze-piece kit - Mundstückkit 8,0/9,8 mm  
066045



included  
066069

included  
Ø6 mm  
066052

	M5	066083
	M6	066090
	M8	066106
	M10	066113
	M12	066120
	M14	066137

M5 → M14  
M5 → M8

Kit 6 tirants pour pose d'écrous à sertir et goujons à sertir  
- Blind rivet nut pulling, Blind rivet bolt adapter kit  
- Blindnietmuttern, Blindnietgewindebolzen-Kit  
066076



included

OPTION FOR GYSPOT ARC PULL (details p.17)

for GYSPOT ARCPULL 350

for GYSPOT ARCPULL 700

ARC PULL RIVET BOX2 350 - 50kN 073388				
Ø 5 x 50 mm 070745	Canon long + mandrin M5 - Long barrel + mandrel M5 070738	Support porte-goujon - Mandrel support 059634	Buse + pad 059641	Buse d'extraction 50Kn Ø 5 066151
x100	x1	x1	x1	x1

ARC PULL RIVET BOX 700 068452										
Ø 5 x 50 mm 070745	Canon long + mandrin M5 - Long barrel + mandrel M5 070738	Buse d'extraction 50Kn Ø 5 066151	Support porte-goujon - Mandrel support 071377	Buse + pad 059641	Ring holder 059610	Fourche pour anneau - Rod for pulling rings 071384	Vis de butée	Ø 5 x 50 mm 066236	Ø 5 x 50 mm 066243	Ø 5 x 50 mm 066250
x100	x1	x1	x1	x1	x2	x1	x1	x1	x1	x1

BOÎTE CONSOMMABLES POUR ADAPTATEUR 50KN - Consumables box for 50kN adapter - Zubehörbox für 50 kN Adapter



+ plaque de démonstration - demo metal sheet

Écrous à sertir - Blind rivet nuts	M5 M6 M8 M10 M12 M14					
mm	0.5 → 3.0	0.5 → 3.0	0.5 → 3.0	1.0 → 3.5	1.0 → 4.0	4.5 → 6.0
x 50	x 50	x 50	x 50	x 50	x 50	x 10
	066175	066182	066199	066205	066212	066229
+ plaque de démonstration - demo metal sheet	x 10	x 10	x 10	x 10	x 10	x 5

Goujons à sertir - Blind rivet bolts	M5 M6 M8		
mm	22.5 → 27	24 → 28.5	23.5 → 28
mm	0.5 → 3.0	0.5 → 3.0	0.5 → 3.0
X 50	X 50	X 50	
	066236	066243	066250
+ plaque de démonstration - demo metal sheet	x 10	x 10	x 10

Rivets aveugles - Blind rivets	Ø 6.4 Ø 9.8	
mm	2.8 → 4.8	3.0 → 14.0
x 50	x 50	
	066267	066274
+ plaque de démonstration - demo metal sheet	x 10	x 10

**Pose de rivets auto-perçants**  
- Application of self-piercing rivets - Stanzniet-Verpressen

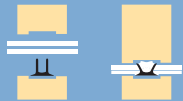

2.0 < 6.5 mm    3 < 5,8 bar

**Pose de rivets pleins**  
- Application of solid rivets - Vollniet-Verpressen



2.3 < 8.3 mm    5,3 < 8 bar

**Pose de rivets Flow-Form**  
- Application of Flow-Form rivets - Setzen v. Fließformnieten

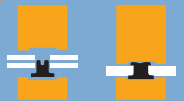

2.3 < 8.3 mm

**Extraction de rivets**  
- Extraction of rivets - Niet-Auspressen



2.3 < 8.3 mm    8 bar

**Perçage et formage des tôles pour rivets pleins** - Metal sheet punching and shaping - Vollniet-Lochstanzen/Prägen



2.3 < 8.3 mm    8 bar

**BOÎTES MATRICES - Dies boxes - Matrzensätze**



**STANDARD**

**STANDARD 8T/10T**

for **8T** **10T**  
053694  
Included **XT11-21** 058644

x1	x1	x1	x1	x1	x1	x1	x2	x1	x1	x1	x1	x1	x2	x4
A1	A2	B1	B2	F1	F2	D17	E1	E2	T1	T2			clé	key
Self-piercing rivets				Flow-form rivets			Extraction		Punching				key	joints
Ø 3.2, 3.5	Ø 3.3	Ø 5, 5.3	Ø 5.3	Ø 6 - A1/2/3 S0/1/2/3/4/5/6			—	Ø 3.3, 4.8	Ø 3.9, 5.3	Ø 6				x1



**STANDARD 8T/10T PUSH PULL**

for **8T PP** **10T PP** **10T CONTROL**  
058361  
Included **XT31-60**  
- 60 mm extension for HR310  
(use with ST1, T5, T7) 057135  
+ **XT11-21** 058644

x1	x1	x1	x1	x1	x1	x1	x2	x1	x1	x1	x1	x1	x2	x4
A1	A2	B1	B2	F1	F2	D17	E1	E2	ST1	T5	T7		clé	key
Self-piercing rivets				Flow-form rivets			Extraction		Punching				key	joints
Ø 3.2, 3.5	Ø 3.3	Ø 5, 5.3	Ø 5.3	Ø 6 - A1/2/3 S0/1/2/3/4/5/6			—	Ø 3.3, 4.8	Ø 3.9, 5.3	Ø 6				x1

**KIT RMB PP05**  
for **10T PP** **10T CONTROL**  
Idéal aluminium, aciers doux - Ideal for aluminum, mild steel 066366

Ø 6.4 mm    **Low pressure**

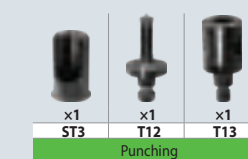
x1	x1	x1
ST3	T12	T13
Punching		
Ø 6.7		

**KIT RMB 08 PREMIUM**  
for **10T** **10T PP** **10T CONTROL**  
Idéal aciers durs, Boron - Ideal for UHSS, Boron 066403

Ø 6.4 mm    **HIGH pressure**

x1	x1	x1
T14	T15	T16
Punching		
Ø 6.7		

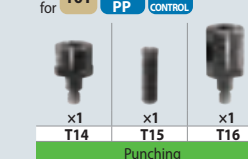
**KIT RMB 14 PREMIUM**  
for **10T** **10T PP** **10T CONTROL**  
Idéal aciers durs, Boron - Ideal for UHSS, Boron 071186

Flow-Form Ø 6 mm

x1	x1	x1
T17	T18	T19
Punching		
Ø 6		

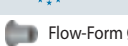
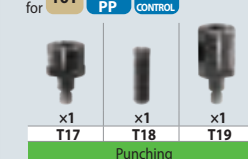
**KIT RMB 15 PREMIUM**  
for **10T** **10T PP** **10T CONTROL**  
Idéal aciers durs, Boron - Ideal for UHSS, Boron 071193

Flow-Form Ø 8 mm

x1	x1	x1
T20	T21	T22
Punching		
Ø 8		

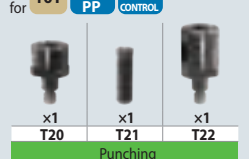
Ne pas utiliser avec une Gyspress 8T & 8T PP - Do not use with Gyspress 8T & 8T PP

**RMB 11** 071087 for **10T**  
**RMB PP04** for **10T PP** **10T CONTROL**  
Included **XT31-60**  
- 60 mm extension for HR310



**GM**

x1	x1	x1	x1	x1	x1	x1	x1	x1	x1	x1	x3	x1	x1	x2	x2	x4	
F1	F2	F6	E9	E11	T1	T2	—	—	ST1	T5	T7	T17	T18	T19	D18	D17	
Flow-form rivets			Extraction		Punching										clé	key	joints
Ø 6			Ø 6,8		Ø 6												

**RMB 06** for **8T** **10T** **8T PP** **10T PP** **10T CONTROL**  
059009



**FERRARI**

x1	x1	x1	x1	x1	x1	x1	x1	x1	x1	x1	x1	x1	x1	x2	x4
B4	B5	B6	S3	S7	S8	D17	E1	E2	E13					clé	key
Self-piercing rivets						Extraction		Punching						key	joints
Ø 3.9	Ø 4.75		Ø 3.9	Ø 4.75		—	Ø 3.3, 4.8		Ø 3.9, 5.3		Ø 4.75				

**RMB 03** for **8T** **10T** **8T PP** **10T PP** **10T CONTROL**  
054257



**VW GROUP**

x1	x1	x1	x1	x1	x1	x1	x1	x1	x1	x1	x1	x1	x1	x1	x1	x1	x1	x1	x2	x4																
A1	B1	S3	S7	S8	D8	D9	D17	D1	D2	D3	D4	D13	E2	S1	S4	S5	D5	D6	D7	D10	D11	D12	D15	D16												
Self-piercing rivets				Solid rivets		Extraction										Punching				clé	key	joints														
Ø 3.2, 3.5	Ø 5, 5.3		Ø 3.9	Ø 4.75		Ø 4		Ø 6		Ø 3.2				Ø 5.3		Ø 3.9, 5.3		Ø 3.2		Ø 5.3		Ø 8		Ø 4.8		Ø 4, 8		Ø 4		Ø 8		Ø 6				

**RMB PP08** for **10T** **10T PP** **10T CONTROL**  
Included **XT31-60**  
- 60 mm extension for HR310



**NIO**

x1	x1	x1	x1	x1	x1	x1	x1	x1	x1	x1	x1	x1	x1	x1	x1	x1	x3	x1	x2	x1	x2	x4			
B1	B2	F1	F2	F6	E2	E3	E9	E11	T5	ST1	T7	T17	T18	T19	D17	D18									
Self-piercing rivets		Flow-form rivets			Extraction			Punching										clé	key	joints					
Ø 5.3		Ø 5.3		Ø 6			Ø 5.3			Ø 6			Ø 6												



**MERCEDES-BENZ**



**RMB 07** for **10T**  
064454

x1	x1	x1	x1	x1	x1	x1	x1	x1	x1	x1	x1	x1	x1	x1	x1	x1	x2		
F1	F2	F3	F4	F5	—	—	—	E9	E10	E11	T1	T2	T3	T4					
Flow-form rivets					Extraction					Punching					clé -key				
Ø 6 - A1/2/3 S0/1/2/3/4/5/6					S28/38/48/58/68					S08/18					Ø 5.3 > 8    Ø 6    Ø 8    Ø 6 > 8    Ø 8    Ø 6    Ø 6    Ø 6    Ø 8				

Included **XT31-60** - 60 mm extension for HR3 (use with E3, E4, E5, E9, E10, E11) 057135



**RMB PP01** for **8T PP** **10T PP** **10T CONTROL**  
058378

x1	x1	x1	x1	x1	x1	x1	x1	x1	x1	x1	x1	x1	x1	x1	x1	x2	
F1	F2	F3	F4	F5	E9	E10	E11	ST1	ST2	T5	T7	T8	T10				
Flow-form rivets					Extraction			Punching					clé -key				
Ø 6 - A1/2/3 S0/1/2/3/4/5/6					S28/38/48 /58/68			S08/18					Ø 6 > 8    Ø 8    Ø 6    Ø 6    Ø 8    Ø 6    Ø 6    Ø 8    Ø 8				

Included **XT31-60** - 60 mm extension for HR3

**FORD**



**RMB PP02** for **10T** **8T PP** **10T PP** **10T CONTROL**  
058835

x1	x1	x1	x1	x1	x1	x1	x1	x1	x1	x1	x1	x2	x4
B1	G1	G2	G3	G4	G5	G6	E7	—	—	E12			
Self-piercing rivets										Extraction		clé -key	joints
Ø 5 > 5.3										Ø 5 > 5.3			

Included **XT31-60** - 60 mm extension for HR3 (use with E7, E8, E12) 057135

**JAGUAR / LAND ROVER**



**RMB 02** for **8T** **10T** **8T PP** **10T PP** **10T CONTROL**  
054271

x1	x1	x1	x1	x2	x1	x1	x2	x4
B1	B2	B3	S8	D17	E1	E6		
Self-piercing rivets				Extraction		clé -key		joints
Ø 5 > 5.3    Ø 5.3    Ø 4.8    Ø 4.75				Ø 3.3 > 4.8    Ø 3.3 > 4.8				

**BMW**



**RMB 01** for **8T** **10T** **8T PP** **10T PP** **10T CONTROL**  
054240

x1	x1	x1	x1	x1	x1	x2	x4	
A1	A2	B1	B2	E1	E2			
Self-piercing rivets					Extraction		clé -key	joints
Ø 3.2 > 3.5    Ø 3.3    Ø 5 > 5.3    Ø 5.3					Ø 3.3 > 4.8    Ø 3.9 > 5.3			



**RMB 12** for **10T**  
071094

x1	x1	x1	x1	x1	x1	x1	x1	x1	x1	x1	x1	x1	x1	x3	x1	x1	x2	x2	x4	
B1	B3	I1	I2	I3	F1	F2	F6	E3	E13	T1	T2	—	—	—	T7	T17	T18	T19	D18	D17
Self-piercing rivets					Flow-form rivets			Extraction		Punching							clé -key	joints		
Ø 5 > 5.3					Ø 6			Ø 3.3 > 4.8    Ø 9		Ø 6										

Included **XT31-60** - 60 mm extension for HR310

**PORSCHE**

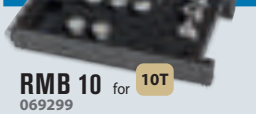

**RMB 10** for **10T**  
069299

x1	x1	x1	x1	x1	x1	x1	x1	x1	x1	x1	x1	x3	x1	x2	x2	x4
B3	F2	E9	E11	—	—	T5	ST1	T7	T17	T18	T19	D17				
Flow-form rivets		Extraction		Punching							clé -key	joints				
Ø 6		Ø 6 > 8		Ø 6												

Included **XT31-60** - 60 mm extension for HR310

**TESLA**

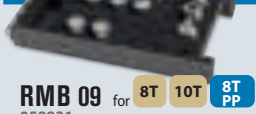

**RMB 09** for **8T** **10T** **8T PP** **10T PP** **10T CONTROL**  
059931

x1	x1	x1	x1	x1	x1	x1	x1	x1	x1	x1	x1	x2	x4	
B1	H1	H2	H3	H4	H5	H6	H7	H8						
Self-piercing rivets													clé -key	joints
Ø 5 > 5.3    Ø 5.3														



**RMB 13** for **10T**  
071100

x1	x1	x1	x1	x1	x1	x2	x1	x1	x1	x1	x1	x1	x1	x1	x1	x2	x4
B1	S7	S8	F3	F4	F5	D17	E2	E3	E9	E10	—	—	—	T3	T4		
Self-piercing rivets			Flow-form rivets			Extraction			Punching					clé -key	joints		
Ø 5 > 5.3    Ø 4.75			S28/38/48/58/68    S08/18			—    Ø 3.9 > 5.3    Ø 5.3 > 8    Ø 6 > 8    Ø 8			Ø 8    Ø 8    Ø 8    Ø 8								

Included **XT31-60** - 60 mm extension for HR3 (use with E2, E3, E9, E10) 057135



## MATRICES - Dies - Matrizen

Pose de rivets auto-perçants  
- Application of self-piercing rivets  
- Stanzniet-Verpressen

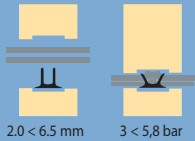

Pose de rivets pleins  
- Application of solid rivets  
- Vollniet-Verpressen

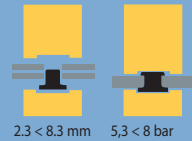

Pose de rivets Flow-Form  
- Application of Flow-form rivets  
- Setzen v. Fließformnieten

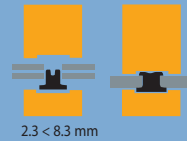

Extraction de rivets  
- Extraction of rivets  
- Niet-Auspressen

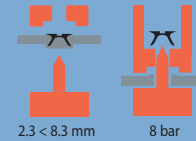

Perçage et formage des tôles pour rivets pleins  
- Metal sheet punching and shaping  
- Vollniet-Lochstanzen/Prägen

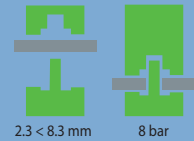

Ø 8																				
x1	x1	x1	x1	x1	x1	x1	x1	x1	x1	x1	x1	x1	x1	x1	x1	x1	x1	x1	x1	x1
A1	A2	B1	B2	B3	B4	B5	B6	D1	D2	D3	D4	D5	D6	D7	D8	D9	D10	D11	D12	D13
055698	055704	055711	055728	055735	059016	059023	059030	055971	055988	055995	055742	056008	056015	056022	056039	056046	055674	056060	056053	055759
A1+A2		B1+B2																		
054295		054301																		

x1	x1	x1	x1	x1	x5	x1	x1	x1	x1	x1	x1	x1	x1	x1	x1	x1	x1		
D15	D16	D17	D18	E1	E2	E3	E6	E7	E9	E10	E11	E12	E13	F1	F2	F3	F4		
056077	056084	055681	071155	055865	054288	055766	057005	057142	057159	058606	058613	058620	058828	059085	055773	055780	055797	055803	
				E1+E2												F1+F2			
				054318												054714			

x1	x1	x1	x1	x1	x1	x1	x1	x1	x1	x1	x1	x1	x1	x1	x1	x1	x1	x1
F5	F6	G1	G2	G3	G4	G5	G6	H1	H2	H3	H4	H5	H6	H7	H8	I1	I2	I3
055810	071148	057173	057180	057197	057203	057210	057227	068230	068247	068254	068261	068278	068285	068292	068308	071117	071124	071131

Ø 6										Ø 6		Ø 6			Ø 8		Ø 6.7		
x1	x1	x1	x1	x1	x1	x1	x1	x1	x1	x5	x1	x1	x1	x1	x1	x1	x1	x1	
S1	S3	S4	S5	S7	S8	ST1	ST2	ST3	T1	T2	T3	T4	T5	T7	T8	T10	T12	T13	
057036	057043	057050	057067	057074	057081	058071	058088	066397	057098	059078	057104	055827	055834	058019	058033	058040	058064	066373	066380
										T1+T2									
										054707									

BREVET GYS  
GYS PATENT

x1	x1	x5	x1	x1	x1	x5	x1	x1
T14	T15	T16	T17	T18	T19	T20	T21	T22
066410	066427	068964	066434	069312	069329	071254	069336	070936
070943	071261	070950						

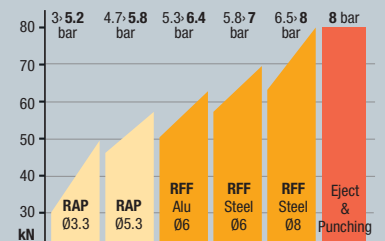

## RIVETS AUTOPERÇANTS (RAP)

- Self piercing rivets (SPR) - Stanznieten

Steel - Acier - Stahl

Complete box  
048706

x200 048232	x200 048249	x100 048256	x100 048263	x100 048270	x100 048225	x100 048638	x100 048645

## POINTEAU CENTREUR

- Special center punch  
- Spezialkörner

048379





**RIVETUSE HYDRO-PNEUMATIQUE** - Hydropneumatic tool for blind rivets - Hydro-pneum. Blindnietgerät

**HR9**

Pour rivets POP - For BLIND rivets - Für Blindniet

Acier / Steel	Ø 3.2/4.0/4.8
Alu	Ø 3.2/4.0/4.8

**max 9 000 N**

057234

Made in Taiwan



**RIVETUSE HYDRO-PNEUMATIQUE** - Hydropneumatic tool for blind rivets - Hydro-pneum. Blindnietgerät

**HR14**

Pour rivets POP - For BLIND rivets - Für Blindniet

Acier / Steel	Ø 4.0/4.8/6.4
Alu	Ø 4.0/4.8/6.4

**max 14 000 N**

057241

Made in Taiwan



**RIVETUSE SUR BATTERIE** - Cordless riveter - Akku-Blindnietgerät

**TWO ER20** 064461

Pour rivets POP - For BLIND rivets - Für Blindniet

Ø 4.0/4.8/5.0/6.0/6.4
-----------------------

**max 20 000 N (6 bar)**  
10-20V universal fast charger (30 min)  
2.0 kg



20V/2Ah Li-ion battery

2 x

**RIVETUSE MANUELLE** - Manual tool for blind rivets - Manueller Blindnietgerät

Pour rivets POP - For BLIND rivets - Für Blindniet

Acier / Steel	Ø 3.2/4.0/4.8/6./6.4
Alu	Ø 3.2/4.0/4.8/6./6.4

061323

Made in Taiwan



**SERTISSEUSE HYDRO-PNEUMATIQUE RIV 998** - Hydro-pneumatic tool for rivet nuts - Hydro-pneum. Blindnietmutterngerät

**RIV 998**

Ecrous à sertir - Sealing nuts - Blindnietmuttern

Pour la pose d'écrous à sertir M3 à M12  
For sealing nuts from M3 to M12

**max 19 000 N (6 bar)**  
livré avec accessoires pour écrous à sertir:  
- included accessories for sealing nuts :

- ✓ M3
- ✓ M4
- ✓ M5
- ✓ M6
- ✓ M8
- ✓ M10
- ✓ M12

055414



MADE IN ITALY

**RIVETUSE HYDRO-PNEUMATIQUE** - Hydro-pneumatic tool for blind rivets - Hydro-pneum. Blindnietgerät

**HR21**

Pour rivets POP - For BLIND rivets - Für Blindniet

Ø 4.0 → 7.8
-------------

**max 21 000 N (6 bar)**

055407



MADE IN ITALY

included (x3) 058446

For standard rivets Ø 4.0 51508

For Magnarive rivets Ø 4.5 51507

Option HR21 extension 100 mm 063105







# GMAW MIG/MAG SYNERGIC



### CARMIG

**15 → 200 A** 

400V • 3~

032132

with accessories 



### M1 GYS AUTO

**15 → 160 A** **Capacitor** 

230V • 1~

032903

208/240V • 1~ 

032088

with accessories 

### T1 GYS AUTO

**15 → 200 A** 

400V • 3~

032910

**T1 GYS AUTO DV** 

400V • 3~ / 230V • 3~

032927

with accessories 

### Capacitor

M1 GYS AUTO, M3 GYS AUTO  
> PERFECT WELD

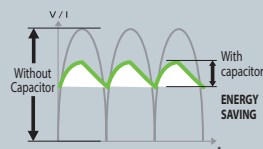

PATENTED REGULATED WIRE SPEED  
EUROPEAN TRADEMARK DESIGN

### SYNERGIC - EASY TO USE

Réglage automatique de la vitesse \ Auto adaptative wire speed  
Automatische Einstellung der Drahtgeschwindigkeit

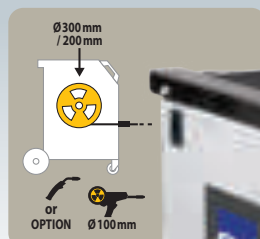

ACCESSORIES BOX



### Torche motorisée Spool Gun - Spool Gun Torch - Spool Gun Brenner



041486

- Ø 100
- Ideal for
- Acier/Steel/Stahl
- Inox/Stainless steel
- Alu



included 045699



SPOOL GUN + Support  
for M3 & T3 GYS AUTO

038554



059276



15L / min  
(FR) 041998  
(UK) 040274  
(NL) 040267  
(IT) 038691



OPTIMAPRO  
30L / min  
(FR) 043619  
(UK) 043626  
(DE) 043633  
(NL) 043640



30L / min  
(FR) 041622  
(UK) 041646  
(DE) 041219  
(NL) 041615  
(IT) 038707



041332



**T3 GYS & M3 GYS :**  
Housse de protection  
- Protection cover  
- Schutzhaube

052260



**MB 15 (150 A)**  
041226

x3	x5	x3
	x5 (M6-Ø0,6)	
	x5 (M6-Ø0,8)	
	x5 (Alu-M6-Ø0,8)	



041806

M3 GYS AUTO

15 **160 A**

Capacitor

230V • 1~

032880

T3 GYS AUTO

15 **200 A**

400V • 3~

032958

T3 GYS AUTO DV

400V • 3~ / 230V • 3~

032972

with accessories:

Steel 150 A, 3 m, air  
Ø 0,8 063754

Steel 150 A, 3 m, air  
Ø 1,0 072121

For T3 GYS AUTO only

with accessories:

032941

câble secteur - mains cable  
6m



Youtube

2 x 4 m<sup>3</sup>  
(20L)

2x

100%  
READY

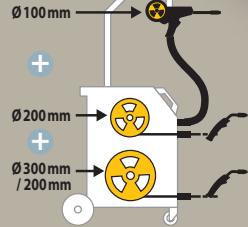

Protection gas  
Argon+CO<sub>2</sub> (Steel, Inox)  
Argon (ALU/CuSi3/CuAl8)  
CO<sub>2</sub>PUR (Steel)



MULTIPEARL



75

# INVERTER SYNERGIC

PFC POWER FACTOR CORRECTION

185 V ← 265 V



FV FLEXIBLE VOLTAGE

85 V ← 265 V

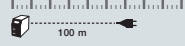

SR SECONDARY REGULATION

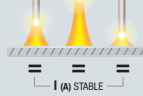

MULTIPEARL AUTO

200 A

∅ 200/300

2 m

P400 PFC FV SR GAS NO GAS MMA TIG

075412

3 m + 2.5 m, 16 mm<sup>2</sup> + 2 m, 16 mm<sup>2</sup>



10/25 mm<sup>2</sup>  
∅ 9 mm

SPECIFIC SYNERGIES  
FOR CAR BODY

AUTOGYS

GMVW  
FCVW  
SYNERGIC MIG

MADE IN FRANCE	MADE IN GYS CHINA	CE NORM. 60974/1	50/60 Hz	A	min → max	Reg	∅ mm		Electronic Control	EN60974-1 (40°C)		∅ mm	cm/kg	Protected & compatible power generator (+/-15%)		
							100 (spoolgun)	200 300		IA (60%)	X% (I2 max)					
			400V 3~	10	15 → 200	7	-		electronic	110	150A@25%	0,6+1	0,6/0,8	0,8	47x77x79 / 50	5 kVA
			230V 1~	16	15 → 160	6	option			90	140A@15%	0,6+1	0,6/0,8	0,8	47x77x79 / 46	4,5 kVA
			208/240V 1~													
			400V 3~	10	15 → 200	7	option			110	150A@25%	0,6+1	0,6/0,8	0,8	47x77x79 / 52	5,2 kVA
			230V 3~/400V 3~													
			230V 1~	16	15 → 160	6				90	140A@15%	0,6+1	0,6/0,8 0,8/1,0	2x 0,8	60x90x90 / 58	4,5 kVA
			400V 3~	10	15 → 200	7				110	150A@25%	0,6+1	0,6/0,8 0,8/1,0	2x 0,8	60x90x90 / 75	5,2 kVA
			230V 3~/400V 3~													
			110V 1~	32	20 → 150	-				100	150 A @22%	0,6+1	0,8/1,0	0,8	41x73x77 / 37	7,5 kW
			230V 1~	16	20 → 200					130	200 A @22%					



GYS AUTO

# GMAW MIG/MAG INVERTER SYNERGIC

Lastest generation  
colour screen 3.5"

**NEW**

### 10 languages

- French
- English
- German
- Italian
- Spanish
- Czech
- Dutch
- Russian
- Chinese
- Japanese

### EASY



### EXPERT

Pre-gas / Creep speed/ Hotstart /  
Crater filler / Burnback / Post-gas



### E1 GYS AUTO

10 **200 A**

230V 1~

PFC

with accessories :

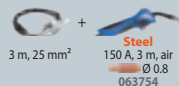

075122

### E2 GYS AUTO

10 **200 A**

230V 1~

PFC

with accessories :



075139

### E3 GYS AUTO

10 **200 A**

230V 1~

PFC

with accessories :

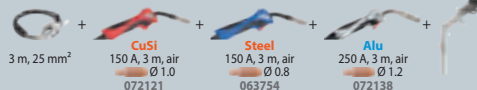

075160

**NEW**  
01 / 2023

### EASY TO SETUP



### MODES

- MANUEL
- SYNERGIC EASY / EXPERT
- 2T
- 4T
- SPOT
- DELAI

### FONCTIONS

- TRACEABILITY
- PORTABILITY
- +500 JOBS can be saved

### SYNERGIES

- STEEL
- AlSi
- AlMg
- Cu Si 3 / CuAl 8
- CrNi

### UPDATES

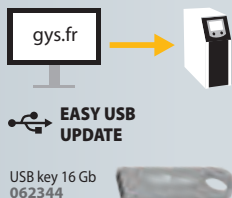

E1 GYS AUTO 200 A • x 1

MADE IN FRANCE	60974/1	
▪	E1 GYS AUTO	
▪	E2 GYS AUTO	
▪	E3 GYS AUTO	



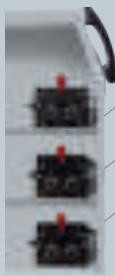

E1 GYS AUTO		
1	Ø 200 / 300	
2	-	-
3	-	-

E2 GYS AUTO		
1	Ø 200	
2	Ø 200 / 300	
3	-	-

E3 GYS AUTO		
1	Ø 200	
2	Ø 200	
3	Ø 200	

**10 → 200 A**  
 Ideal 0,6 mm

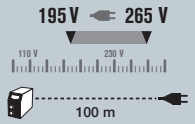
**PFC POWER FACTOR CORRECTION**

**NEW**  
01 / 2023



**NEW**  
01 / 2023

2 x 4 m<sup>3</sup>  
(20L)

2 x 4 m<sup>3</sup>  
(20L)

2 x

6 m

6 m

3 x

**E2 GYS AUTO 200 A • x 2**

**E3 GYS AUTO 200 A • x 3**

Cable	50/60 Hz	A	6 m	min → max A	Ø mm		Electronic Control	EN60974-1 (40°C)		Ø mm	Equipment d'origine Original equipment Originalausstattung Equipamiento de fabrica	cm	kg	Protected & compatible power generator (+/-15%)
					200	300		IA (60%)	X% (I2 max)					
230 V 1 ~	16	6 m	10 → 200	■	■		145	20	0.6 → 1	Acier Type B 0.6/0.8	74 x 49 x 78	43	9KVA	
230 V 1 ~	16	6 m	10 → 200	■	■		145	20	0.6 → 1	Acier Type B 0.6/0.8 Alu Type B 0.8/1	87.5 x 63 x 90	49	9KVA	
230 V 1 ~	16	6 m	10 → 200	■	■		145	20	0.6 → 1	Acier Type B 0.6/0.8 Acier Type B 0.8/1 Alu Type B 0.8/1	87.5 x 63 x 90	51	9KVA	



# GMAW MIG/MAG INVERTER DOUBLE PULSE

Latest generation  
colour screen 5"  
800 x 480 (WVGA)



## ▶ ACCESSIBILITY

3 interface levels

10 languages

- EASY
- EXPERT
- ADVANCED

- French
- English
- German
- Italian
- Spanish
- Czech
- Dutch
- Russian
- Chinese
- Japanese

EASY



ADVANCED  
Arc length adjustments



EXPERT  
Pre-gas / Hot Start / Upslope / Downslope /  
Crater filler / Post-gas



3 INTERFACE LEVELS

## ▶ 500+ JOBS can be saved



## ▶ TRACEABILITY



## ▶ PORTABILITY



## ▶ MODES

- DYNAMIC STANDARD
- PULSE
- PULSE IN PULSE
- MANUAL
- COLD PULSE**

## ▶ FULLY DIGITAL

4 MICROPROCESSORS



## ▶ 65+ SYNERGIES

Retrouvez toutes les synergies :  
Find all the synergies:  
Finde alle Synergien :



- STEEL
- Cu Si 3 / Cu Al 8
- ALU

## ▶ UPDATES

EASY USB UPDATE



USB key 16 Gb  
062344





**OPTIONS**

**PUSH PULL TORCH 24V**

Motor inside

**MB 15**  
4 m  
0441111

**MB 25**  
4 m  
046283

**MB 15 / MB 25 (250 A)**  
037458

x5 (M6-Ø 0.8)  
x5 (M6-Ø 1.0)  
x5 (Alu - M6-Ø 0.8)

x5 (M6-Ø 0.8)  
x5 (M6-Ø 1.0)  
x5 (Alu - M6-Ø 1.0)  
x5 (Alu - M6-Ø 1.2)

Débitmètre de bout de torche  
053939

Housse de protection  
- Protection cover  
- Schutzhaube  
052260

**AUTOPULSE 220-M1**

1	Ø 200 / 300		PP
-	-	-	-

**AUTOPULSE 220-M2**

1	Ø 200 / 300		PP
2	Ø 200 / 300		-

**ELECTRONIC**

**AUTOPULSE 220-M1**

**15 220 A** 230V 1~ **PFC**

with accessories:

4 m, 35 mm<sup>2</sup> 043817 + Alu 250 A, 3 m, air Ø 1.2 072138

**065024**

**BODYSHOP SPECIFIC**

**COLD PULSE**

**CuSi3 Ø 0.8/1**

**AUTOPULSE 220-M2**

**15 220 A** 230V 1~ **PFC**

with accessories:

4 m, 35 mm<sup>2</sup> 043817 + Steel 150 A, 3 m, air Ø 1.0 072121 + Alu 250 A, 3 m, air Ø 1.2 072138

**069855**

**AUTOPULSE 220-M1 208-240V**

**15 220 A** 208>240V 1~ **PFC**

with accessories:

4 m, 35 mm<sup>2</sup> 043817 + Alu 250 A, 3 m, air Ø 1.2 072138

**070868**

**AUTOPULSE 220-M2 208-240V**

**15 220 A** 208>240V 1~ **PFC**

with accessories:

4 m, 35 mm<sup>2</sup> 043817 + Steel 150 A, 3 m, air Ø 1.0 072121 + Alu 250 A, 3 m, air Ø 1.2 072138

**069862**

10 m<sup>3</sup> (50L) 1x

2 x 4 m<sup>3</sup> (20L)

8 m

8 m

2x

**PFC POWER FACTOR CORRECTION**

185 V ← 265 V

100 m

**220 A • x 1**

**220 A • x 2**

 MADE IN FRANCE EN60974-1	 50 / 60 Hz	 A	 Ø mm	 min → max	 SPOOLGUN	 PUSHPULL	 Ø mm	 Cooling system	 ELECTRONIC CONTROL	Equipement d'origine Original equipment Originalausstattung Equipamiento de fabrica		EN60974-1 (40°C)	 cm / kg	 Protected & compatible power generator (+/-15%)
										IA (60%)	X% (I2 max)			
<b>AUTOPULSE 220-M1</b>	230 V · 1 ~	8 m	16	0.6 → 1.2	10 → 220	-	<b>OPTION</b>	■ ■ Air		ALU : Type B 1.0 / 1.2	150	220 A @ 20%	88x93x63 / 69	10 kVA
<b>AUTOPULSE 220-M1 208-240V</b>	208 > 240 V · 1 ~	8 m	16	0.6 → 1.2	10 → 220	-	<b>OPTION</b>	■ ■ Air		ALU : Type B 1.0 / 1.2	150	220 A @ 20%	88x93x63 / 69	10 kVA
<b>AUTOPULSE 220-M2</b>	230 V · 1 ~	8 m	16	0.6 → 1.2	10 → 220	-	<b>OPTION</b>	■ ■ Air		ACIER : Type B 0.8 / 1.0 mm ALU : Type B 1.0 / 1.2	150	220 A @ 20%	88x93x63 / 69	10 kVA
<b>AUTOPULSE 220-M2 208-240V</b>	208 > 240 V · 1 ~	8 m	16	0.6 → 1.2	10 → 220	-	<b>OPTION</b>	■ ■ Air		ACIER : Type B 0.8 / 1.0 mm ALU : Type B 1.0 / 1.2	150	220 A @ 20%	88x93x63 / 69	10 kVA





AUTOPULSE

# GMAW MIG/MAG

## INVERTER DOUBLE PULSE

BODYSHOP SPECIFIC  
**COLD PULSE**  
CuSi3 Ø 0.8 / 1



Helmet not included

2 x 4m<sup>3</sup>  
(20L)

3 x

8m

**PFC** POWER FACTOR CORRECTION

185 V ~ 265 V

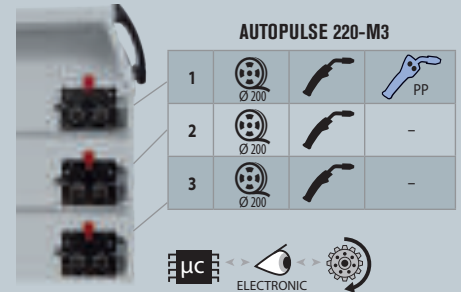
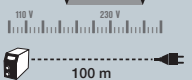

AUTOPULSE 220-M3

1			PP
2			-
3			-

**ELC** ELECTRONIC

**TESLA**  
APPROVED EQUIPMENT

**AUTOPULSE 220-M3**

15 **220 A**

230V 1~

**PFC**

with accessories :



036703

**AUTOPULSE 220-M3 208-240V**

15 **220 A**

208>240V 1~

**PFC**

with accessories :



062481

### OPTIONS

#### PUSH PULL TORCH 24 V

- MB 15**  
4m  
0441111
- MB 25**  
4m  
0462823

Motor inside

- MB 15 / MB 25 (250 A)**  
037458
- x5 (Mg-Ø0.8)
- x5 (Mg-Ø1.0)
- x5 (Alu - Mg-Ø0.8)
- x5 (Mg-Ø0.8)
- x5 (Mg-Ø1.0)
- x5 (Alu - Mg-Ø1.0)
- x5 (Alu - Mg-Ø1.2)

Débitmètre de bout de torche  
053939

Housse de protection - Protection cover - Schutzhaube  
052260

**220 A • x 3**

<b>MADE IN FRANCE</b> <b>CE NORM.</b> EN60974-1	50 / 60 Hz	8 m	A Ø mm	min → max A	SPOOLGUN	PUSH/PULL	200	Cooling system	Equipement d'origine Original equipment Originalausstattung Equipamiento de fabrica		EN60974-1 (40°C)		cm / kg	Protected & compatible power generator (+/-15%)
									ELECTRONIC CONTROL	IA (60%)	X% (I2 max)			
<b>AUTOPULSE 220-M3</b>	230 V · 1~	8 m	16	0.6 → 1.2	10 → 220	-	<b>OPTION</b>	■	Air	ACIER : Type B 0.6 / 0.8 ACIER : Type B 0.8 / 1.0 ALU : Type B 1.0 / 1.2	150	220 A @ 20%	88x93x63 / 69	10 kVA
<b>AUTOPULSE 220-M3 208-240V</b>	208 > 240 V · 1~	8 m	16	0.6 → 1.2	10 → 220	-	<b>OPTION</b>	■	Air	ACIER : Type B 0.6 / 0.8 ACIER : Type B 0.8 / 1.0 ALU : Type B 1.0 / 1.2	150	220 A @ 20%	88x93x63 / 69	10 kVA

	AUTOPULSE 320-T1			AUTOPULSE 320-T3			AUTOPULSE 320-T3 208-240V		
1			PP			PP			PP
2	-	-	-						-
3	-	-	-			-			-



**AUTOPULSE 320-T1**

**15 320 A** 400V 3~

with accessories :

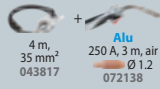

**NEW**

069831

**AUTOPULSE 320-T1 208-240V**

**15 320 A** 208>240V 3~ PFC

with accessories :

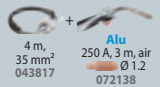

069848



1 x

5 m



2 x 4m³ (20L)

5 m

**AUTOPULSE 320-T3**

**15 320 A** 400V 3~

with accessories :

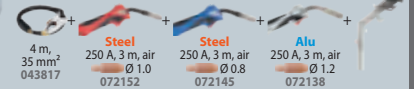

067615

**AUTOPULSE 320-T3 208-240V**

**15 320 A** 208>240V 3~ PFC

with accessories :

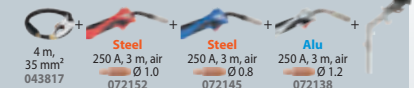

036970

3 x

**OPTIONS**

for AUTOPULSE 320-T3 (400 V) only

**SPOOLGUN TORCH**

**Ideal Alu**



4 m 041486

Motor inside

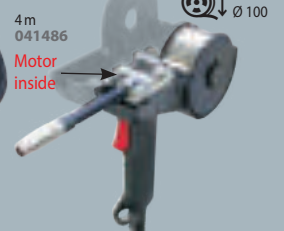

**320 A • x 1**

**320 A • x 3**

 MADE IN FRANCE	 EN60974-1	 50 / 60 Hz	 A	 Ø mm	 min → max	 SPOOLGUN	 PUSH/PULL	 Ø mm	 Cooling system	 ELECTRONIC CONTROL	Equipement d'origine Original equipment Originalausstattung Equipamiento de fabrica		EN60974-1 (40°C)		 Protected & compatible power generator (+/-15%)	
											ALU : Type B 1.0 / 1.2	ACIER : Type C 0.8 / 1.0 mm ALU : Type C 1.0 / 1.2	IA (60%)	X% (I2 max)		cm / kg
<b>AUTOPULSE 320-T1</b>		400 V · 3 ~	5 m	16	0.6 → 1.2	15 → 320	-	OPTION	■ ■	Air		ALU : Type B 1.0 / 1.2	260	320 A @ 35%	90x92,5x63 / 82.5	16 kVA
<b>AUTOPULSE 320-T1 208-240V</b>		208 > 240 V · 3 ~	5 m	25	0.6 → 1.2	15 → 320	-	OPTION	■ ■	Air		ALU : Type B 1.0 / 1.2	260	320 A @ 35%	90x92,5x63 / 82.5	16 kVA
<b>AUTOPULSE 320-T3</b>		400 V · 3 ~	5 m	16	0.6 → 1.2	15 → 320	OPTION	OPTION	■ -	Air		ACIER : Type C 0.8 / 1.0 mm ALU : Type C 1.0 / 1.2	260	320 A @ 35%	75x40x94 / 82.5	16 kVA
<b>AUTOPULSE 320-T3 208-240V</b>		208-240 V · 3 ~	5 m	25	0.6 → 1.2	15 → 320	-	OPTION	■ -	Air		ACIER : Type C 0.8 / 1.0 mm ALU : Type C 1.0 / 1.2	260	320 A @ 35%	75x40x94 / 82.5	16 kVA

**TORCHES MANUELLES** - Manual Torches - Brenner - Antorcha - Lastoort - Tocha

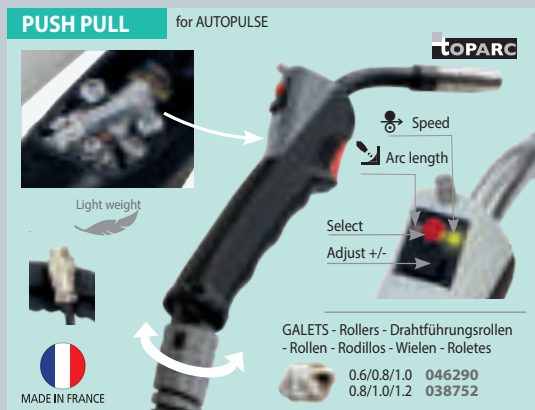
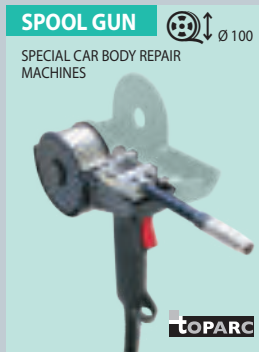
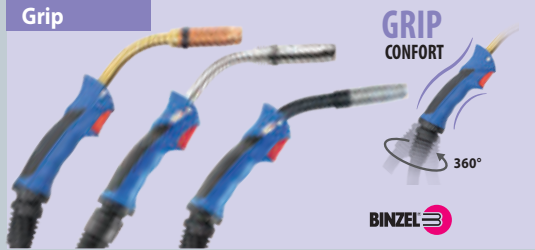

**Coffrets** - Boxes - Verschleißteilebox - Cajas - Kistjes - Estojos

MB 15 (150 A) 041226	MB 15 / MB 25 037458	MB 25 (250 A) 041233	MB 36 (350 A) 041417
x3	x5 (M6-Ø0.8) x5 (M6-Ø1.0) x5 (Alu - M6-Ø0.8)	x5	x2
x5	x5 (M6-Ø0.8) x5 (M6-Ø1.0) x5 (Alu - M6-Ø1.0) x5 (Alu - M6-Ø1.2)	x3	x3
x5 (M6-Ø0.6) x5 (M6-Ø0.8) x5 (Alu - M6-Ø0.8)	x5 (M6-Ø0.8) x5 (M6-Ø1.0) x5 (Alu - M6-Ø1.0)	x5 (M8-Ø1.0) x5 (M8-Ø1.2) x5 (Alu - M8-Ø1.0) x5 (Alu - M8-Ø1.2)	x5 (M8-Ø1.0) x5 (M8-Ø1.2) x5 (Alu - M8-Ø1.0) x5 (Alu - M8-Ø1.2)
x3	x3	x3	x2

**Gaines** - Torch liners - Mantel - Funda - Drahtseelen - Folie

ACIER - STEEL - STAHL - ACERO - STAAL - AÇO	TEFLON	
0.6x0.8 3m 041592 4m 041837	0.6x0.8 3m 041578	0.6x0.8 3m 044050
0.8 3m 041608 4m 041844 5m 062276	0.8x1.2 3m 041585 4m 044067 8m 038677 4m 044074	0.8x1.2 3m 041585 4m 044067 8m 038677 4m 044074
0.12 & 1.6 3m 418417 4m 418424 5m 062283	0.12 & 1.6 4m 039834 5m 062306 4m 039827 5m 062313	0.12 & 1.6 4m 039834 5m 062306 4m 039827 5m 062313
0.16 & 2.4 4m 040526 5m 062290	0.16 & 2.4 4m 039810	0.16 & 2.4 4m 039810
<b>PUSH PULL TORCH</b>		
Ø 1.0/1.2	8m	038172

**CONSUMMABLES** - Consumables

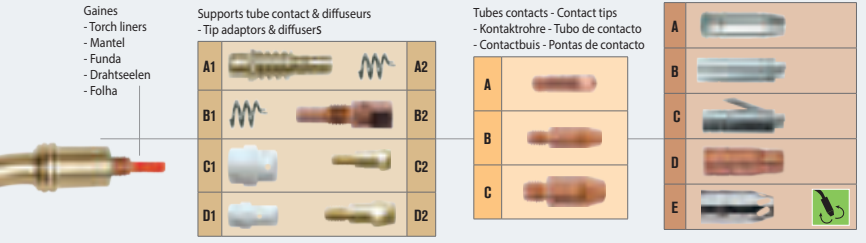

**Torches complètes** - Complete Torches - Brenner - Antorcha - Lastoort - Tocha

	Acier / Inox - Steel/Stainless steel - Stahl/Edelstahl						ALU - Aluminium - Aluminio					PUSH PULL		SPOOL GUN
	AIR			LIQUID			AIR			LIQUID		AIR		AIR
	150A	150A	250A	250A	350A	300A	150A	250A	250A	350A	300A	160A	220A	150A
X% 40°C, Ar/CO <sub>2</sub>	150A 60%	150A 60%	150A 60%	200A 60%	290A 60%	270A 100%	150A 60%	150A 60%	200A 60%	290A 60%	270A 100%	160A 40%	220A 20%	150A 60%
	A1+A2	A1+A2	B1+B2	B1+B2	D1+D2	C1+C2	A1+A2	A1+A2	B1+B2	D1+D2	C1+C2	A1+A2	B1+B2	A1+A2
	M6	M6	M6	M6	M8	M6	M6	M6	M6	M8	M6	M6	M6	M6
	Ø0.8	Ø1.0	Ø0.8	Ø1.0	Ø1.2	Ø1.2	Ø0.8	Ø1.2	Ø1.0	Ø1.2	Ø1.2	Ø1.0	Ø1.2	Ø0.8
3m	063754	072121	072145	072152	063792	040694	063761	072138	063785	063808	040748	044111	046283	041486
3m	041424			063778	040687	043275	041462		040724	CARBON 040731	043282			
3m	043268			040700	040946				040939	CARBON 040953				
3m	043251			040922	040557									
							3m							
							040540							

**Supports tube contact & diffuseurs** - Tip adaptors & diffusers

	Acier / Inox - Steel/Stainless steel - Stahl/Edelstahl						ALU - Aluminium - Aluminio					PUSH PULL		SPOOL GUN
	AIR			LIQUID			AIR			LIQUID		AIR		AIR
	150A	150A	250A	250A	350A	300A	150A	150A	250A	350A	300A	150A	250A	150A
	A1 (x5)	A1 (x5)	B1 (x5)	B1 (x5)	D1 (x3)	C1 (x3)	A1 (x5)	A1 (x5)	B1 (x5)	D1 (x3)	C1 (x3)	A1 (x5)	B1 (x5)	A1 (x5)
	042902	042902	042995	042995	043008	043589	042902	042902	042995	043008	043589	042902	042995	042902
	A2 (x10)	A2 (x10)	B2 (x5)	B2 (x5)	D2 (x5)	C2 (x5)	A2 (x10)	A2 (x10)	B2 (x5)	D2 (x5)	C2 (x5)	A2 (x10)	B2 (x5)	A2 (x10)
	042988	042988	042919	042919	042926	043541	042988	042988	042919	042926	043541	042988	042919	042988

**Tubes contacts** - Contact tips - Kontaktröhre - Tubo de contacto - Contactbuis - Pontas de contacto

	150A	150A	250A	250A	350A	300A	150A	150A	250A	350A	300A	150A	250A	150A
Ø 0.6	A (x10) 041905	A (x10) 041905	A (x10) 041905	A (x10) 041905	—	A (x10) 041905	—	—	—	—	—	—	—	—
Ø 0.8	A (x10) 041912	A (x10) 041912	B (x10) 041950	B (x10) 041950	C (x10) 041790	B (x10) 041950	B (x10) 041059	B (x10) 041059	B (x10) 041059	—	B (x10) 041059	B (x10) 041059	B (x10) 041059	B (x10) 041059
Ø 1.0	A (x10) 041929	A (x10) 041929	B (x10) 041967	B (x10) 041967	C (x10) 419803	B (x10) 041967	B (x10) 041066	B (x10) 041066	B (x10) 041066	C (x10) 419766	B (x10) 041066	B (x10) 041066	B (x10) 041066	B (x10) 041066
Ø 1.2	A (x10) 040144	A (x10) 040144	B (x10) 041974	B (x10) 041974	C (x10) 419810	B (x10) 041974	B (x10) 041073	B (x10) 041073	B (x10) 041073	C (x10) 419773	B (x10) 041073	B (x10) 041073	B (x10) 041073	B (x10) 041073
Ø 1.4	—	—	—	—	C (x10) 419827	—	—	—	—	—	—	—	—	—
Ø 1.6	—	—	—	—	C (x10) 419834	—	—	—	—	C (x10) 041080	—	—	—	—
Ø 2.4	—	—	—	—	C (x10) 040533	—	—	—	—	—	—	—	—	—

**Buses** - Gas nozzles - Düsen - Tubo - Nippel - Bicos

	150A	150A	250A	250A	350A	300A	150A	150A	250A	350A	300A	150A	250A	150A
	Ø 12	Ø 12	Ø 15	Ø 15	Ø 16	Ø 17	Ø 12	Ø 12	Ø 15	Ø 16	Ø 12	Ø 12	Ø 15	Ø 12
Conique Conical nozzle Könische Düse	A (x3) 041875	A (x3) 041875	A (x3) 041882	A (x3) 041882	A (x3) 041783	A (x3) 043534	A (x3) Ø 12	A (x3) Ø 12	A (x3) Ø 15	A (x3) Ø 16	A (x3) Ø 12	A (x3) Ø 12	A (x3) Ø 15	A (x3) Ø 12
Pointage Spot welding Punktdüse	E (x1) 043084	E (x1) 043084	E (x1) 040571	E (x1) 040571	E (x1) 040588	—	—	—	—	—	—	—	—	—
Pointage Spot welding Punktdüse	B (x1) 041851	B (x1) 041851	—	—	—	—	A (x3) Ø 16	A (x3) Ø 16	—	—	—	A (x3) Ø 17	—	—
Pointage Spot welding Punktdüse	C (x1) 041523	C (x1) 041523	—	—	—	—	046214	046214	—	—	—	046221	—	—
Pointage Spot welding Punktdüse	D (x1) 041868	D (x1) 041868	—	—	—	—	—	—	—	—	—	—	—	—
Special No Gas (isolated)	—	—	—	—	—	—	—	—	—	—	—	—	—	—



for	kg			Ø 0.6 mm	Ø 0.8 mm	Ø 0.9 mm	Ø 1.0 mm	Ø 1.2 mm	EXCELLIUM			NORMES - Norms - Normen - Norma						
									Ø 0.8 mm	Ø 1.0 mm	Ø 1.2 mm	AWS	EN	DIN				
Acier - Steel - Stahl - Acero - Staal - Aço	0.9	100 mm	—	086593	086609								5.18 : ER 70S-6	ISO 14341-A : G46 4M G3Si1	8559 : SG2			
	5	200 mm	—	086111	086128		086135											
	15	300 mm	—	086166	086227		086234	086241		086302	086319							
	18	—	300 mm		086272		086289	086296										
	5	200 mm	—	086418	086401											5.18 : ER 70S-3	ISO 14341-A : G42 2M 2Si1	8559 : SG1
	15	300 mm	—		086258											5.28 : ER 90S-B3	ISO 21951-A : Cr CrMo2Si	—
	5	200 mm	—		077157											5.28 : ER120 S-G	ISO 16834 : Mn4Ni2_5CrMo	—
	5	200 mm	—		086203											ASME SFA-5.28 : ER 120 S-G	ISO 12534 : Mn4Ni2_5CrMo	—
	0.9	100 mm	—			086104												
	4.5	200 mm	—			086265	086623	086630									5.20 : E71T-GS	ISO 17632-A T42 Z W N 1 H15
15	300 mm	—				086388	086395											
16	—	300 mm						086173					—	14700 : TZ Fe 2	8555 : MSG 6-CF-60			
5	200 mm	—	086760	086777									5.18 : ER 70S-2	ISO 14341-A : G42 2 M G2Ti	8559 : SG2			
1	100 mm	—		086692									5.7 : ER CuSi-A	ISO 14640 : S Cu 6560	1733 : SG-CuSi3			
5	200 mm	—		086647			086654		086210									
5	200 mm	—		086661			086197						5.7 : ER CuAl-A1	ISO 14640 : S Cu 6100	1733 : SG-CuAl8			
15	300 mm	—					086180											
CrNi	1	100 mm	—		086616								5.9 : ER 308L Si	ISO 14343-A : G19 9 L Si	8556 : SG X2 CrNi 19 9			
	5	200 mm	—		086579		086340											
	15	300 mm	—				086357											
	5	200 mm	—		086326		086364						5.9 : ER 316L Si	ISO 14343-A : G19 12.3 L Si	8556 : SG X2 CrNiMo 19 12			
15	300 mm	—				086371												
Aluminium	2	200 mm	—					086517					5.10 : ER 5554	ISO 18273 : S Al 5554	1732 : SG-ALMg3			
	7	300 mm	—					086500										
	0.5	100 mm	—		086548													
	2	200 mm	—		086555		086562						5.10 : ER 5356	ISO 18273 : S Al 5356	1732 : SG-ALMg5			
	7	300 mm	—				086524	086531										
	7	—	300 mm							086487	086494							
	0.5	100 mm	—		086685								5.10 : ER 4043	ISO 18273 : S Al 4043-A	1732 : SG-AISi5			
	2	200 mm	—		077133		086142	086159										
0.5	100 mm	—		086678														
2	200 mm	—		077140		086067	086074					5.10 : ER 4047	ISO 18273 : S Al 4047	1732 : SG-AISi12				
7	300 mm	—					086043											
2	200 mm	—					073432					5.10 : ER4145	ISO 18273 : S Al 4145	—				

GALETS - Rollers - Vorschubrollen - Rollen - Rodillos - Wielen - Roletes

	TYPE A	TYPE B	TYPE C
	Carmig Ø 30mm / Ø 9mm	Auto GYS - Autopulse 220, 320T1 - M1GYS - M3GYS - T1GYS - T3GYS - E1 / E2 / E3 GYS AUTO Ø 37mm / Ø 9mm	Neopulse - Autopulse 320 T3 Ø 37mm / Ø 19mm
Acier - Steel - Stahl - Acero - Staal - Aço	Ø 0.6 / 0.8 (x1) 042339	(x1) 042087 (x2) 042353	(x2) 041738
Inox - Stainless	Ø 0.8 / 1.0 (x1) 041189	(x1) 042100 (x2) 042360	(x2) 042094
Alu	Ø 1.0 / 1.2 (x1) 042179	(x2) 046849	(x2) 042117
Fil fourré - Cored wire	Ø 1.2 / 1.4 (x1) 041196	(x2) 042384	(x2) 039780
	Ø 1.2 / 1.6 (x1) 041196	(x2) 042377	(x2) 041752
	Ø 0.8 / 1.0 (x1) 042155	(x2) 042377	(x2) 042148
	Ø 1.0 / 1.2 (x1) 042186	(x2) 040915	(x2) 042162
	Ø 1.2 / 1.6 (x1) 042186	(x2) 042391	(x2) 041776
	Ø 0.8 / 0.9 (x1) 046856		
	Ø 0.9 / 1.2 (x1) 042346	(x1) 042131 (x2) 042407	(x2) 042124

KIT SOUDAGE NO GAZ Ø 0.9 - No Gas Welding Kit Ø 0.9

041240

M6-Ø0.9 (x3) + Isolated Nozzle No Gas - 150 A (x1)

Ø 0.9 / 1.0 (x1) Type A

Monomig 160-1, Easymig 150/160/160XL, Smartmig 142/152/162/3P/182/183, Multipearl 200-2

RACCORDS GAZ - Gas connector - Gasanschlüsse

x2 045712

Ø 8 x1 046245

x1 067936

Tuyau caoutchouc - Rubber hose Ø 6.3 X 13 (EN ISO 3821)

1.5 m 066670  
4 m 046269  
∞ x m 046276

PINCE SPÉCIALE MIG/MAG-ORIGINAL FIX - Special MIG/MAG plier - Spezial MIG/MAG Zange - Pinza especial MIG/MAG

PRO (x1) 041332

1) Clean 2) Cut 3&4) Prepare (contact tube & nozzle)

ADAPTATEURS BOBINES - Adaptors for wire reels - Korbspulenadapter

ALIGNER 200 Ø 200 042889

After sales Press & Lock

Professional 71608 Ø 200 & 300

Industrial 71613 Ø 200 & 300

SUPPORT TORCHE MAGNÉTIQUE - MIG torch stand with magnetic base

041653

DÉBIMÈTRE DE BOUT DE TORCHE - Torch gas flow-meter

053939

SPRAY PROTECTEUR (SANS SILICONE) - Anti-spatter spray (without silicone) - Antihafspray (Ohne Silikon)

041806

# HELMETS

## TECHNOLOGY

	Intensity (A)														
	1.5	70	100	125	150	175	200	225	250	300	350	400	450	500	600
MAG	8	9	10				11			12				13	
MIG		9	10				11		12		13		14		
MIG light alloys				10			11		12		13		13		
PLASMA		9	10	11			13								

### Teinte initiale - Initial shade



Classic

ULTRA CLEAR

### Spectre de couleur - Spectrum view

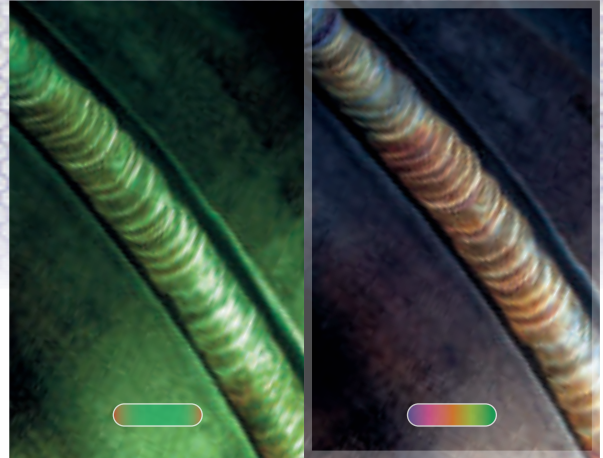

Classic

TRUECOLOR

### Capteurs sensibles - Sensitivity sensors

Classic

HIGH SENSIBILITY



Sensors x2



Sensors x4



Sensors x7

### Classification - X=/X=/X=/X=

1/1/1/1 = PERFECT QUALITY

(1) Qualité optique (distorsion). (2) Diffusion de la lumière (contraste). (3) Variation de la transmission lumineuse (homogénéités de la teinte foncée). (4) Lumière angulaire (filtre de rayons lumineux diagonaux).

(1) Optical quality (distortion). (2) Light diffusion (contrast). (3) Variation of light transmission (homogeneities of the dark shade). (4) Angular light (diagonal light ray filter).

(1) / (2) / (3) / (4)

### Serre-tête - Headgear



Simple



Multi



MULTI PRO



MULTI PREMIUM

Comfortable back

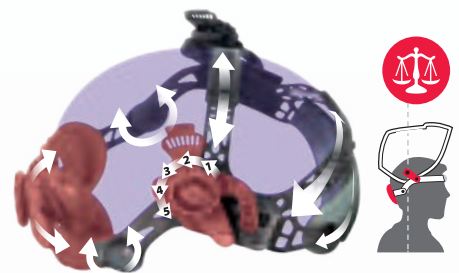

MULTI PREMIUM PRO

Comfortable back / Perfect stability

# HELMETS

9-13



**LCD FIREMAN 9-13  
TRUECOLOR**  
062269

IDEAL



**LCD GYSMATIC 9/13 G  
TRUECOLOR**  
043909

◀ 100 x 49 mm | □ → ■ 0.1 ms



◀ 100 x 60 mm | □ → ■ 0.08 ms



# HELMETS

5-9/9-13

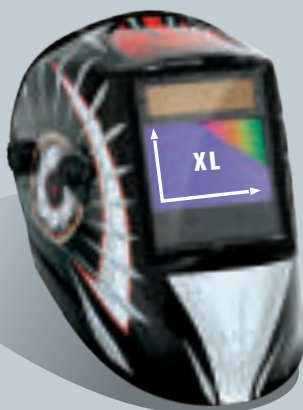

**ZEUS 5-9/9-13 G  
INDIAN**  
038332



**ZEUS 5-9/9-13 G  
FIRE**  
044098



**ZEUS 5-9/9-13 G  
COSMIC**  
044104

◀ 100 x 67 mm

□ → ■ 0.1 ms



TRUECOLOR

OPTIONS



Sac pour masque de soudage  
- Carry bag for helmet welding  
043299

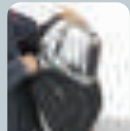

066656



Bandeau anti-transpiration  
- Antiperspirant - headband  
043466  
for Multi Premium, Multi Premium Pro, Multi, Simple  
062627  
for Multi Pro  
070844  
for Gysmatic 9/13 Air, Gysmatic 5/13 Air XXL



Loupe - Magnifying glass  
for Zeus, Ergotech & Alien True Color x1  
zoom x2  
042780  
zoom x3  
064140

VERRES - Lenses - Schutzgläser

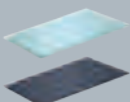

				TRUECOLOR	□ → ■	□ → ■ HF	□ → ■ DELAY	↻	)))	◀ ▶	🔊	🔍	🔧	👤	MASK BRAND
226 x 106 (x5)	045781	103.6 x 54 (x5)	040809	LCD FIREMAN 9-13 TRUECOLOR	4-9>13	■	0.10 ms	—	0,15 > 0,8 s	1/1/1/2	2	100x49 mm	■	—	☀ Multi Premium 490 g Gys
114x133 (x10)	043893	G: 106 x 66 (x10)	043886	LCD GYSMATIC 9/13 G TRUECOLOR	4-9>13	■	0.08 ms	✓	0.10>0.90 s	1/1/1/2	4 HIGH SENSITIVITY	XL: 100x60 mm	■	✓ +2 (CR 2450)	Simple 580 g Gys
114 x 133 (x10)	043893	103.7 x 69.5 (x5)	043695	ZEUS	4-5>9 / 9>13	■	0.10 ms	—	0.15 > 0.8 s	1/1/1/2	4	XL: 100x67 mm	■	✓ +2 (CR 2450)	Multi 520 g Gys



# HELMETS

5-9/9-13

## ERGOTECH +

◀ 100 x 67 mm



+ ◻ → ◼ 0.1 ms

+ ULTRA CLEAR 3

+ CLASS 1/1/1/1

TRUCOLOR



Multi Premium



ERGOTECH + 5-9/9-13  
SILVER  
068650



ERGOTECH + 5-9/9-13  
BLACK  
068667

## ALIEN +



ALIEN XXL +  
TRUCOLOR  
068698

◀ 100 x 90 mm

+ ◻ → ◼ 0.1 ms



+ ULTRA CLEAR 3

+ CLASS 1/1/1/1

TRUCOLOR



Multi Premium



GYSMATIC XL  
TRUCOLOR  
037908

◀ 100 x 60 mm

◻ → ◼ 0.08 ms



CLASS 1/1/1/1

TRUCOLOR



OPTIONS



Sac pour masque de soudage  
- Carry bag for helmet welding  
043299



066656



Bandeau anti-transpiration  
- Antiperspirant - headband

043466  
for Multi Premium, Multi Premium Pro, Multi, Simple

062627  
for Multi Pro



070844  
for Gysmatic 9/13 Air, Gysmatic 5/13 Air XXL



Loupe - Magnifying glass  
for Zeus, Ergotech & Alien True Color  
x1  
zoom x2  
042780  
zoom x3  
064140

VERRES  
- Lenses  
- Schutzgläser

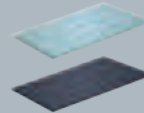

◻ → ◼	◻ → ◼	◻ → ◼
114 x 133 (x10)	043893	103.7 x 69.5 (x5) 043695
114 x 133 (x10)	043893	104 x 96 (x5) 043596
110 x 90 (x5)	040816	106 x 66 (x10) 043886
114 x 133 (x10)	043893	106 x 89.5 (x10) 046825
114 x 133 (x10)	043893	103.7 x 69.5 (x5) 043695
390 x 150 (x3)	037311	special kit (x1) 037304

# PANORAMIC

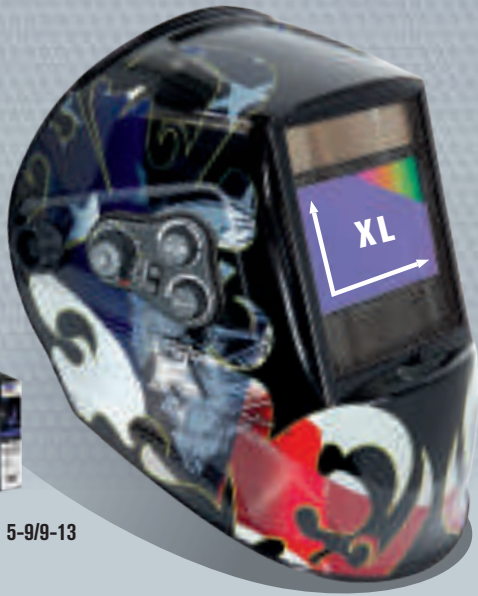

**ERGOTECH + 5-9/9-13 DREAM**  
068674



## APOLLO +

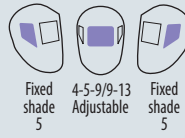

**APOLLO + 5-9/9-13 G TRUECOLOR**  
068681

◀ 100 x 67 mm

⊕ ◻ → ◼ 0.1 ms

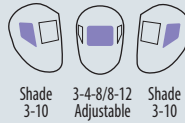

**PANORAMIC 3XL TRUECOLOR**  
037281

◀ 114 x 85 mm

◻ → ◼ 0.15 ms



**DIGITAL MEMORY & REGULATIONS ELECTRONIC**

memory saving x3

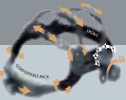

Multi Pro



**GYSMATIC XXL TRUECOLOR**  
037236

◀ 100 x 83 mm

◻ → ◼ 0.1 ms



		TRUECOLOR	◻ → ◼	◻ → ◼ HF	◻ → ◻ DELAY	⚙	)))	◀ ▶	🔍	⚡	🔧	👤	MASK BRAND
<b>ERGOTECH +</b>	3-5>9/9>13	▪	0.10 ms	—	0.15 > 0.8 s	1/1/1/1	4 HIGH SENSITIVITY	XL: 100x67 mm	▪	✓	☀ + 2 ⚡ (CR 2450)	Multi Premium	580 g Gys
<b>ALIEN XXL + TRUECOLOR</b>	3-5>9/9>13	▪	0.10 ms	✓	0.15 > 0.8 s	1/1/1/1	4 HIGH SENSITIVITY	XXL: 100x90 mm	▪	—	☀ + 2 ⚡ (CR 2032)	Multi Premium	560 g Gys
<b>GYSMATIC XL TRUECOLOR</b>	4-5>9/9>13	▪	0.08 ms	✓	0.1 > 0.9 s	1/1/1/1	4 HIGH SENSITIVITY	XL: 100x60 mm	▪	✓	☀ + 2 ⚡ (CR 2450)	Multi	540 g Gys
<b>GYSMATIC XXL &amp; 5/13 AIR XXL TRUECOLOR XXL</b>	4-5>9/9>13	▪	0.10 ms	✓	0.1 > 0.9 s	1/1/1/1	4 HIGH SENSITIVITY	XXL: 100x83 mm	▪	✓	☀ + 2 ⚡ (CR 2450)	Multi Pro	680 g Gys
<b>APOLLO + 5-9/9-13 G</b>	3-5>9/9>13 + 2x: 5	▪	0.10 ms	—	0.15 > 0.8 s	1/1/1/1	4 HIGH SENSITIVITY	XL: 100x67 + 2x103.7x69.5 mm	▪	✓	☀ + 2 ⚡ (CR 2450)	Multi Premium	580 g Gys
<b>PANORAMIC 3XL TRUECOLOR</b>	3-4>8/8>12 + 2x: 3>10	▪	0.15 ms	✓	0.15 > 0.8 s	1/1/1/1	4 HIGH SENSITIVITY	114x85 + 2x(68x80) mm	▪	—	☀ + 2 ⚡ (CR 2450)	Multi	610 g Gys



# HELMETS VENTILATED

IDEAL

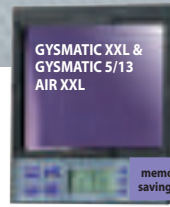
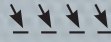

DIGITAL

MEMORY & REGULATIONS  
ELECTRONIC



LCD GYSMATIC 9/13 G  
AIR TRUECOLOR  
065727  
GB: 069602

◀ 100 x 60 mm

☐→■ 0.08 ms



included with LCD  
GYSMATIC 9/13 G  
TRUECOLOR

GYSMATIC 5/13 AIR XXL  
TRUECOLOR  
047846  
GB: 028852

◀ 100 x 83 mm

☐→■ 0.1 ms

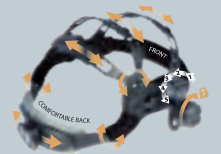

Multi Pro



Filtration class  
EN 12941 : TH2 P R SL  
Air 165 / 200  
220 L/min  
Battery included

OPTION  
Filter TH3  
065734



Battery charger  
037472  
GB: 028869



Battery included  
037465

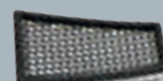

038424 x1



038417 x5

VERRES  
- Lenses  
- Schutzgläser



114 x 133 (x10) 043893	G: 106 x 66 (x10) 043886
114 x 133 (x10) 043893	106 x 89,5 (x10) 046825

	TRUECOLOR	☐→■	☐→■ HF	☐→■ DELAY		)	◀ ▶								MASK BRAND
LCD GYSMATIC 9/13 G TRUECOLOR	4-9>13	0.08 ms	✓	0.10>0.90 s	1/1/1/2	4 HIGH SENSITIVITY	XL : 100x60 mm	✓	☀ +2 (CR 2450)	Simple	580 g	Gys			
GYSMATIC 5/13 AIR XXL TRUECOLOR XXL	3-4>8 / 8>13	0.10 ms	✓	0.1 > 0.9 s	1/1/1/1	4 HIGH SENSITIVITY	XXL : 100x83 mm	✓	☀ +2 (CR 2450)	Multi Pro	680 g	Gys			



**ASPIRATEURS DE FUMÉE - Fume Extraction Systems - Rauchgasabsauggerät**

**UNI 2.0 RE**

- 400V 3 ~
- 50 Hz
- 1 100 W
- 1 500 m<sup>3</sup>/h max

- arm 3 m
- no plug
- 100 kg
- extraction 0.5 m/s

061545



Ø 150 mm

**EVO 2.1 RE**

- 230V 1 ~
- 50 Hz
- 1 100 W
- 1 200 m<sup>3</sup>/h max
- occasionnal

- arm 3 m
- included
- 85 kg

061552



Breveté  
-Patented

Ø 150 mm

792 mm

347 mm

**EVO 2.2**

- 230V 1 ~
- 50 Hz
- 1 100 W
- 1 100 m<sup>3</sup>/h max
- occasionnal

- arm 3 m
- included
- 85 kg

073814



Included

**Pré filtre, treillis Aluminium**  
Class of filtration G3 EN 779  
+ **Filtre - Coal Filter EPA E12**  
EN 779, Filtration >99.5 %

046467

Options

**Filtre à charbon actif -**  
Coal filter  
✓ UNI 2.0 RE

064522

**Extraction flexible**

10 m, Ø 152 mm  
✓ UNI 2.0 RE  
✓ EVO 2.1 RE

062139



Included

**Pré filtre, treillis Aluminium**  
Class of filtration F15 G2 EN 779  
+ **Filtre - Coal Filter HEPA H13**  
EN 779, Filtration >99.95%

046498

Included

**Pré filtre, treillis Aluminium**  
Class of filtration F15 G2 EN 779  
+ **Filtre - Coal Filter HEPA H13**  
EN 779, Filtration >99.95%

075177

**TORCHES ASPIRANTES - Fume Extraction Torches - Rauchgas-Absaugbrenner - Antorcha con aspiración de humos**



Pour torches aspirantes - for fume Extraction Torches

**NEW**



**BINZEL**

073715

- 230V / 1 ~, 1 100 W
- 230 m<sup>3</sup>/h max
- 190 mbar max
- 25 kg, 590 x 425 x 825 mm
- 76 db
- Système de nettoyage automatique du filtre - Filter auto cleaning system - Automatische Filterabreinigung

Filtre Classe M, EN 60335-2-69



included :  
5 m, Ø50

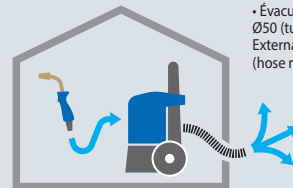

• Évacuation extérieure  
Ø50 (tuyau non inclus) -  
External evacuation Ø50  
(hose not included)



Acier/Inox - Steel/Stainless steel - Stahl/Edelstahl

	AIR			LIQUID
	150 A	250 A	350 A	500 A
original equipment	M6	M6	M8	M8
Ø	Ø 0.8	Ø 1.0	Ø 1.2	Ø 1.2
X % 40°C - ArCo <sub>2</sub>	150A - 60%	200A - 60%	290A - 60%	380A-100%
GRIP	GRIP	GRIP	GRIP	GRIP
L	3 m	3 m	4 m	4 m
Ref.	043251	040540	040557	040564



# INDUCTION HEATING

 CAR BODY

PFC POWER FACTOR CORRECTION

185 V ← 265 V



### PACKS - GYSDUCTION AUTO

	PROLINER AUTO 048775	COMPLETE AUTO 053380	COMPLETE AUTO+ 056978	MECA AUTO 048812	MECA AUTO+ 056961	BODY SHOP AUTO 048799	GLASS AUTO 048805	DENT REPAIR AUTO 054981
 1 box	=	=	=	=	=	=	=	=
 GYSDUCTION AUTO	✓	✓	✓	✓	✓	✓	✓	✓
 Plastic wedges 051294	✓	✓	✓	—	—	✓	✓	—
 Burn off Inductor 053373	✓	✓	✓	—	—	✓	✓	—
 Body Inductor 053359	✓	✓	✓	—	—	✓	—	—
 Bolt Inductor 053366	✓	✓	✓	✓	✓	—	—	—
 Remote control 055490	✓	✓	✓	✓	✓	✓	—	—
 Universal 800 051331	✓	—	—	—	—	—	—	—
 Cable support 052284	✓	—	—	—	—	—	—	—
 Dent pulling Inductor 054776	—	—	—	—	—	✓	—	✓
 Spiral inductor 054783	—	—	✓	—	✓	—	—	—



055490

 GYSDUCTION AUTO

**2 400 W** 230 V • 1~

PFC AIR

CONSUMABLES



for



Protection (x5)  
+ Colle - Stick  
053854



for



Protection (x1)  
+ Colle - Stick  
059108



for



Protection (x10)  
+ Colle - Stick  
053847

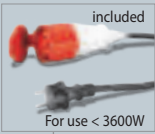

included C20/B1  
056862

3 m



**COMBIDUCTION AUTO 50LG**

**5 200 W** | 230 V • 1 ~

**PFC** ❄️ **LIQUID**

065901



**INCLUDED COMBIDUCTION**

Décapage  
Glass  
Entfernen  
053373



Décollage  
Decal  
Entkleben  
053359



**OPTIONS**

Inducteur spirale  
- Spiral inductor  
- Spiralinduktor  
054783



Débosselage sans peinture  
- PDR : Paintless Dent Repair  
- Lackschadenfreies Ausbeulen  
054776

Licensed by  
BETAG innovation



Spray  
refroidisseur  
- Freezer spray



(x 12)  
048898

Adhesive for logo  
(x10)  
051492



			A	W					kHz	PFC	Liquid Cooling	Inductor	Inductor			
<b>GYSDUCTION AUTO</b>		230V, 1~, 50/60 Hz	16 mini	2400	35±100	▪		2	2.5	M10 → 1 s	2 mm → 5 s	Ø8 → 10 s	36 x 27 x 22	7.5	3 kW	
<b>COMBIDUCTION AUTO 50LG</b>		230V, 1~, 50/60 Hz	25 mini	5 200	20±80	▪	▪ 7 l	8	3	M14 → 1 s	2 mm → 3 s 4 mm → 5 s	Ø10 → 10 s	59 x 88 x 59	72	6 kW	





POWERDUCTION

# INDUCTION HEATING

MAINTENANCE / MECHANIC / INDUSTRY

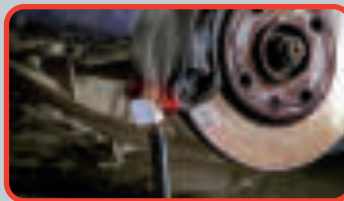
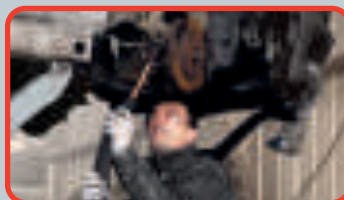

### INCLUDED

Spirale - Coil - Spiralförmiger draht

Ø 18 mm  
054806

Ø 24 mm  
054790

Ø 30 mm  
055469

Fil tressé enroulable - Flexible  
wrappable wire - Flexibel  
geflochtener draht



800 mm  
054813

Fil droit rigide - Straight rigid wire  
- Steif gerade draht



800 mm  
054868

### PFC POWER FACTOR CORRECTION

185 V ← 265 V

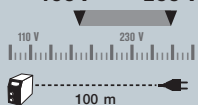

3 m

included C20/B1  
056862



1 m



2 m

included S90  
058927



### POWERDUCTION 10R

1 200 W

230 V • 1 ~

AIR

062504

068643

### POWERDUCTION 37LG

3 700 W

230 V • 1 ~

LIQUID

056992

072510

### POWERDUCTION 39LG

3 700 W

230 V • 1 ~

PFC LIQUID

058583

### OPTION 10R

Decal - Décollage - Entkleben  
066601



### OPTION 37LG

Cable  
support  
052284



Chariot - Trolley  
UNIVERSAL 800  
051331



Youtube

**t° POWER HEAT CONTROLLER**
**t° CONTROL**  
 80>350°C (210>660°F)

5,5m

**POWER HEAT CONTROLLER**  
 061644

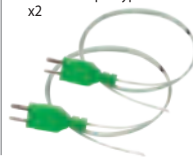
 Included  
 T° sensors  
 thermocouple type K  
 x2

Youtube

**OPTIONS**
**Pyrometer IR**  
 for inductor L90

 1.1 m  
 064119

**Compatibility**

 POWERDUCTION 110LG  
 POWERDUCTION 110LG 208-240 V  
 POWERDUCTION 160LG  
 POWERDUCTION 160LG 208-240 V  
 POWERDUCTION 220LG

3 m

4 m

 included  
 For use < 3600W

 included C20/B1  
 056862

 included adapter  
 32L + L90  
 064515 + 059788

**POWERDUCTION 50LG**
**5 200 W**

230 V • 1~

055599

**POWERDUCTION 110LG**
**11 000 W**

400 V • 3~

058590

**POWERDUCTION 110LG 208-240V**
**11 000 W**

208-240 V • 3~

065246

 MADE IN FRANCE				Freq. kHz	INTEGRATED TECHNOLOGY		 Liquid Cooling	Cable L (m)		Heating			 cm	 kg	 Protected & compatible power generator (+/-15%)
		A	W		P400	PFC		Inductor							
<b>POWERDUCTION 10R</b>	230 V, 1~, 50/60 Hz	10 mini	1 200	45→80	—	—	—	2	1	M10 → 1 s	2 mm → 5 s	Ø8 → 10 s	23 x 14 x 10	3	1.5 kW
<b>POWERDUCTION 37LG</b>	230 V, 1~, 50/60 Hz	16 mini	3 700	15→30	—	—	▪ 1.5 l	2	2	M10 → 1 s	2 mm → 5 s	Ø10 → 15 s	45 x 29 x 25	15	4 kW
<b>POWERDUCTION 39LG</b>	230 V, 1~, 50/60 Hz	16 mini	3 700	20→60	▪	▪	▪ 7 l	4	3	M12 → 1 s	2 mm → 5 s	Ø10 → 15 s	53 x 70 x 37	39.5	4 kW
<b>POWERDUCTION 50LG</b>	230 V, 1~, 50/60 Hz	25 mini	5 200	20→60	▪	▪	▪ 7 l	8	3	M14 → 1 s	2 mm → 3 s 4 mm → 5 s	Ø10 → 10 s	59 x 88 x 59	70	6 kW
<b>POWERDUCTION 110LG 400V</b>	400 V, 3~, 50/60 Hz	16 mini	11 000	20→60	—	—	▪ 7 l	5	4	M18 → 1 s	2 mm → 2 s 4 mm → 4 s	Ø10 → 7 s	59 x 88 x 59	80	15 kW
<b>POWERDUCTION 110LG 208-240V</b>	208-240 V, 3~, 50/60 Hz	35 mini	11 000	20→60	—	—	▪ 7 l	5	4	M18 → 1 s	2 mm → 2 s 4 mm → 4 s	Ø10 → 7 s	59 x 88 x 59	86	15 kW





**t° POWER HEAT CONTROLLER**

**t° CONTROL**  
80>350°C (210>660°F)

5,5m

**POWER HEAT CONTROLLER**  
061644



**POWERDUCTION 160LG**

**16 000 W** | 400 V • 3~

**LIQUID**

057814

**POWERDUCTION 160LG 208-240 V**

**16 000 W** | 208-240 V • 3~

**LIQUID**

065253



**POWERDUCTION 220LG**

**22 000 W** | 400 V • 3~

**LIQUID**

066861

with 10 m cable :  
074576

**OPTIONS**



Poignée de lance  
- Removable handle -  
Abnehmbarer Griff  
for POWERDUCTION  
160 - 220 LG  
068599



Housse de protection  
- Protection cover -  
Schutzhaube  
for POWERDUCTION  
160 - 220 LG  
050853



Cooling liquid  
for POWERDUCTION  
160 - 220 LG  
5L  
062511  
10L  
052246

MADE IN FRANCE	Cable L (m)	Freq.	Liquid Cooling	Cable L (m)			Heating			kg	Protected & compatible power generator (+/-15%)		
				Inductor	Hex	Bar	cm	cm	cm				
<b>POWERDUCTION 160LG 400V</b>	400 V, 3~ 50/60 Hz	32 mini	16 000	20→60	301	4	6	M20 → 1 s	2 mm → 2 s 4 mm → 4 s	Ø10 → 5 s	70 x 118 x 60	136	22 kW
<b>POWERDUCTION 160LG 208-240V</b>	208-240 V, 3~ 50/60 Hz	45 mini	16 000	20→60	301	4	6	M20 → 1 s	2 mm → 2 s 4 mm → 4 s	Ø10 → 5 s	70 x 118 x 60	146	22 kW
<b>POWERDUCTION 220LG</b>	400 V, 3~ 50/60 Hz	32 mini	22 000	20→60	301	4	6	M45 → 3 s	8 mm → 9 s 4 mm → 3 s	Ø10 → 4 s	70 x 118 x 60	141	22 kW
<b>POWERDUCTION 220LG</b>	400 V, 3~ 50/60 Hz	32 mini	22 000	20→60	301	4	10	M45 → 3 s	8 mm → 9 s 4 mm → 3 s	Ø10 → 4 s	70 x 118 x 60	145	22 kW





## INDUCTEURS - Inductors

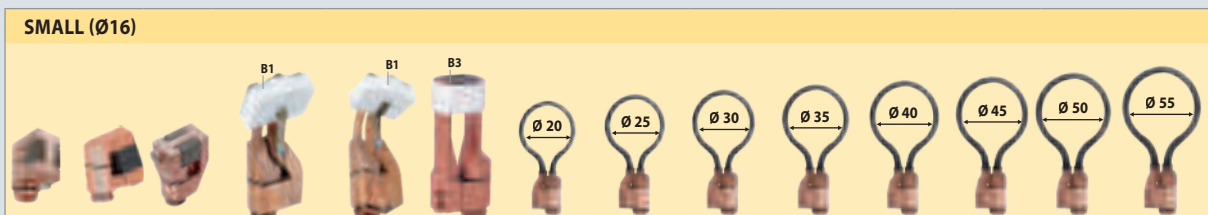

	S90 058927	S70 061569	S180 059269	S20/B1 (20°) 064874	S180/B1 064881	S180/B3W 067899	S180/D20 069985	S180/D25 069992	S180/D30 070592	S180/D35 070608	S180/D40 070615	S180/D45 070622	S180/D50 070639	S180/D55 070646
* = original equipment														
37 LG	✓*			✓				✓						
39 & 50 LG							✓ with adapter 28S							
110 & 160 LG							✓ with adapter 32S							
220 LG							✓ with adapter 32S							

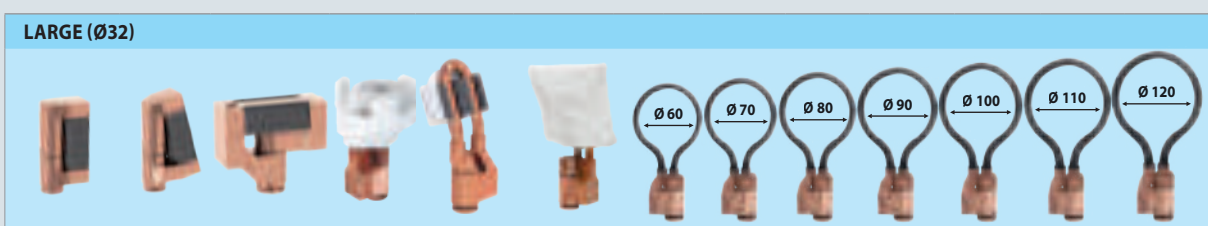

	L90 (90°) 059788	L70 (70°) 059771	L180 059795	L180/Spiral 065000	L20/B4 067882	L20 Alu Glove 069114	L180/D60 069923	L180/D70 069930	L180/D80 069121	L180/D90 069947	L180/D100 069954	L180/D110 069961	L180/D120 069978
* = original equipment													
37 LG													
39 & 50 LG			✓ with adapter 28L									✓ with adapter 28L	
110 & 160 LG	✓* with adapter 32L*			✓ with adapter 32L								✓ with adapter 32L	
220 LG		✓ with adapter 32L			✓ with adapter 32L*							✓ with adapter 32L	

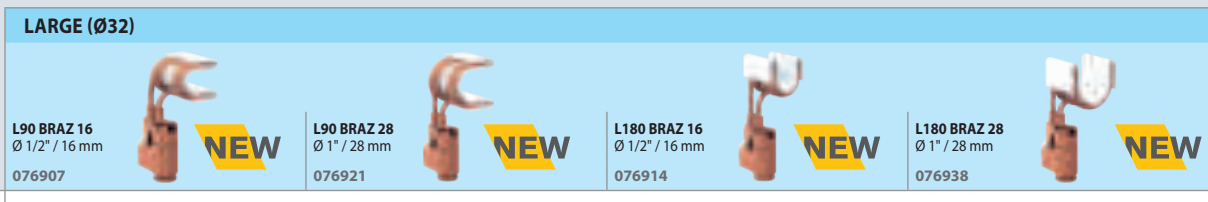

* = original equipment	L90 BRAZ 16 Ø 1 1/2" / 16 mm 076907	L90 BRAZ 28 Ø 1" / 28 mm 076921	L180 BRAZ 16 Ø 1 1/2" / 16 mm 076914	L180 BRAZ 28 Ø 1" / 28 mm 076938
110 & 160 LG			✓ with adapter 32L	
220 LG			✓ with adapter 32L	

	ADAPTER			
	28S M28 Ø16 064485	32S M32 Ø16 064508	28L M28 Ø32 064492	32L M32 Ø32 064515
37 LG				
39 & 50 LG	✓		✓	
110 & 160 LG				✓
220 LG				✓

	COMPLETE (Ø28)		
	C20/B1 (20°) 056862	C180/B1 (90°) 056879	C180/B2 (90°) 056886
* = original equipment			
39 & 50 LG	✓*		✓

## BOÎTES - Boxes

<p><b>S28S/B type W</b> for 39LG &amp; 50LG 072497</p> <p>included: S20/B1 (x1) S180/B1 (x1) S180/B3 (x1) 28S (x1) B1 (x1) B3 (x1)</p>	<p><b>S32S/B type W</b> for 110LG &amp; 160LG 072503</p> <p>included: S20/B1 (x1) S180/B1 (x1) S180/B3 (x1) 32S (x1) B1 (x1) B3 (x1)</p>	<p><b>L box</b> 065796</p> <p>included: L70 (x1) L180 (x1)</p>
--	--	--

## FERRITES - Ferrites - Ferritaufsatz

B1 053823	B2 053458	B3 067875	B4 053755
B1 056909	B2 056916	B3 072527	B4 054844
			Spiral 069701

**Glue kit for inductor**  
Kit de colle pour inducteur  
075948

Colle-Stick  
bi-composants  
Power Epoxy  
150°C  
054851



CUTTER

# PLASMA

1~

COMPRESSOR COMPRESSOR INSIDE

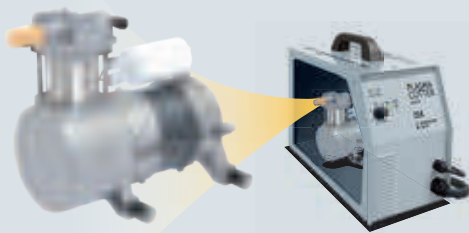

AD ANTI-DUST VENTILATION CORRIDOR

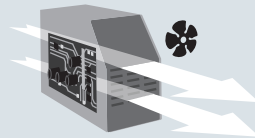

AIR FILTER



NEW NAME

DIGITAL (PRESSURE SENSOR)



INCLUDED: 8mm



## COMPRESSOR Compressor inside

**EASYCUT K25**

230 V • 1 ~

**25 A** Fe 8 mm  
Al/CrNi 6 mm

P400 COMPRESSOR

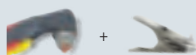

TPT 25, 4 m 2 m, 10 mm<sup>2</sup>

068063

**EASYCUT K35F**

230 V • 1 ~

**35 A** Fe 15 mm  
Al/CrNi 10 mm

P400 PFC AD COMPRESSOR

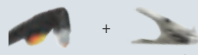

MT35K, 4 m 2 m, 10 mm<sup>2</sup>

031036

**EASYCUT 25**

230 V • 1 ~

**25 A** Fe 8 mm  
Al/CrNi 6 mm

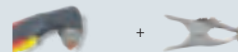

TPT 25, 4 m 2 m, 10 mm<sup>2</sup>

065543

### OPTIONS

**COMPAS**  
for TPT 40, TPT 25, MT 25K / MT 35K

x1  
040199

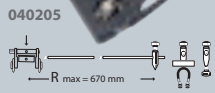

### Consumables

	MT25K	TPT25	MT35K	TPT40
	x4 040182	x4 040236	x4 040229	x4 040236
	x10 040151	x10 040212	x10 040212	x10 040212
	x2 040175	x2 040175	x2 040175	x2 040175
	x10 040168	x10 040168	x10 040168	x10 040168
Coffret - Box	039971	070721	039964	039957

### Chariot - Trolley

PLASMA 600 ↳ 39 x 62 x 58 cm ☐ 30 x 11 x 63 cm 8.8 kg 040298	Universal 800 ↳ 48 x 81 x 62 cm ☐ 52 x 15 x 81 cm 18 kg 051331	Jobsite XL ↳ 60 x 115 x 59 cm ☐ 67 x 25 x 48 cm 039568

Filtre déshumidificateur spécial Plasma - Compressed air cleaning filter for Plasma Cutter 40 039728



Cartouche pour filtre - Filter cartridge 039735





**COFFRET DE DÉCOUPE JOINT DE PARE-BRISE** - Professional Box Set for Windscreen  
 Removal - Frontscheiben-Trennsystem für Akkuschauberbetrieb

MADE IN  
 HIGH  
 QUALITY  
 GERMANY

057654

included  
 Axe enrouleur  
 068100



included  
 65 m  
 resistance 170 kg  
 Ø 0.79 mm  
 058125



optional  
 65 m  
 resistance 190 kg  
 Ø 0.92 mm  
 069275



**COUPEAU PNEUMATIQUE DE DÉCOUPE PARE-BRISE**  
 - Oscillating Pneumatic Saw for Windscreen Removal  
 - Druckluft-Trennmesser für Windschutzscheiben

057623



**SYSTÈME DE DÉCOUPE PARE-BRISE À CLIQUET**  
 - Windshield Cutting Kit - Set zum Lösen von Windschutzscheiben

054738

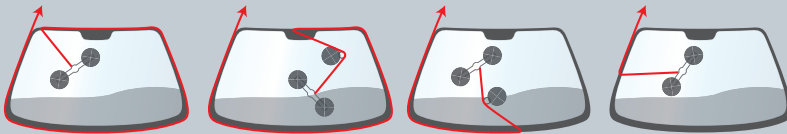

**PROTECTIONS TABLEAU DE BORD**  
 - Dashboard Protector - Armaturenbrett Schutz

053120

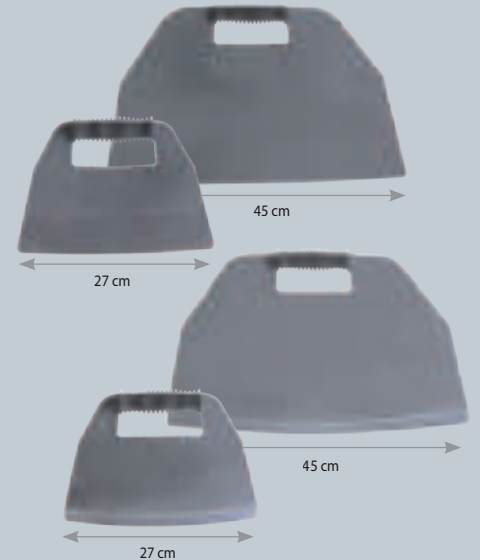

**OUTIL DÉCOUPE PARE-BRISE**  
 - Windshield Cutting Tool - Windschutzscheiben Demontage-Set

051935



**KIT DÉCOUPE JOINT DE PARE-BRISE** - Windscreen Joint-cutting Kit - Scheibentrenn-Werkzeug-Set

051898



Corde à piano torsadé (22 m)  
 - Windscreen seal cutting wire  
 (twisted)  
 - Piano-Schneiddraht, gedrillt,  
 22 m Rolle

051911



Corde à piano carré (50 m)  
 - Windscreen seal cutting wire  
 (square)  
 - Vierkant-Draht,  
 50 m Rolle

051881

**EXTRACTEUR D'ESSUIE-GLACE** - Removal tool for windscreen wiper arms - Wischerarm-Abzieher

**UNIVERSEL**  
057630



**EXPERT**

Accès difficile  
- Difficult access  
057647

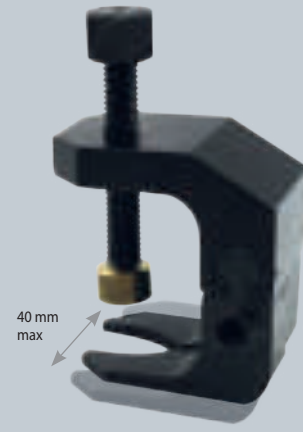

**VENTOUSES** - Suction Lifting Pads - Saugnapfwerkzeug für Spiegelgläser

056695



051966



x6  
057609

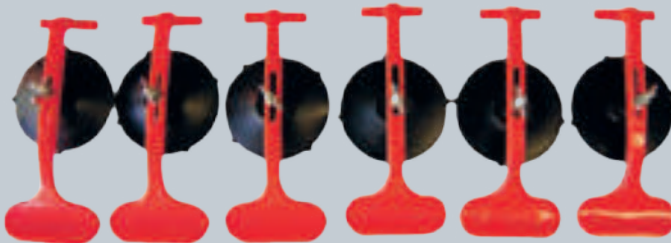

**RENOV'POLYCARBONATE** - Compressed air polisher - Druckluftpolierer

**Complete pack**

1 ponceuse orbitale  
+ 1 lustreuse  
- 1 orbital sander  
+ 1 polisher

052086

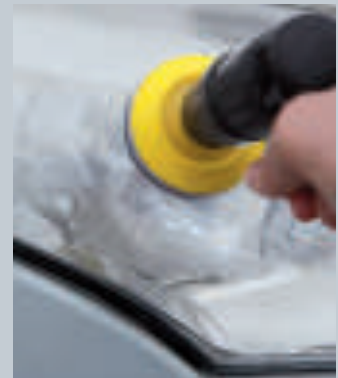
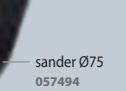
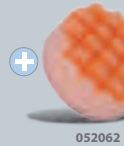

polisher Ø75  
058224

Ø 76

P 500 (x 10)  
P 800 (x 10)  
P 1500 (x 10)  
P 3000 (x 10)



P 500 x 50 052017  
P 800 x 50 052024  
P 1500 x 50 052031  
P 3000 x 50 052048



## AGRAFEUSE POUR RÉPARATION PARE-CHOCS - Hot stapler for bumper repair - Stoßstangen Reparatur Kit

052925



INCLUDED:  
x20 x20 x20 x20 x20

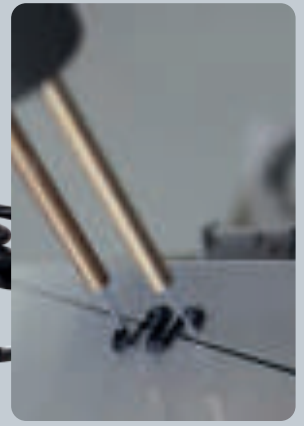

MADE IN TAIWAN

### PORTABLE

Sur batterie - Battery operated  
058118

included  
Li-ion battery 3.7V  
048669

included adapters:  
EUR, UK, USA & AUS

Charger included  
048652

MADE IN TAIWAN

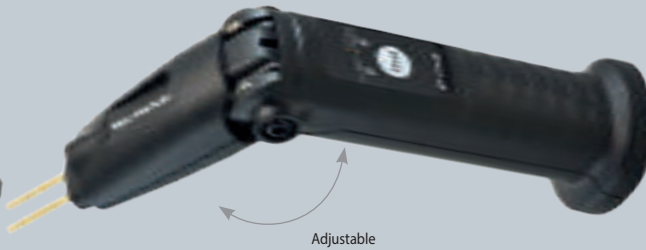

Adjustable

INCLUDED:

Ø 0.6, x100    Ø 0.8, x100

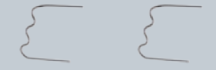

Ø 0.6, x100

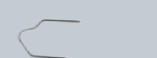

### Agrafes - staples



**V**  
Angle interne étroit  
- Inside corner  
Ø 0.7 mm



x 100  
047990



**U**  
Alignement de fissure  
- Crack alignment  
Ø 0.7 mm



x 100  
047983



**N**  
Fissure importante  
- Large crack  
Ø 0.7 mm



x 100  
047976



**W**  
Angle interne  
- Internal angle  
Ø 0.7 mm



x 100  
047969



**M**  
Angle externe  
- External angle  
Ø 0.7 mm



x 100  
047952



052413

=

x 50

+

x 50

+

x 50

+

x 50

+

x 50

## COFFRET DE PERÇAGE PARE-CHOCS POUR DÉTECTEURS - Piercing Kit for Bumper Sensors - Lochwerkzeug für Stoßfänger



**PRO +**  
059139

➔ ➔ ➔ Ø 17-18-18,2  
19-20-22,5-24  
26-26,7-32 mm



## FREEZER

Spray refroidisseur  
- Freezer spray

**-50 °C**

400 ml

(x 12)  
048898



## OUTIL DE DÉCLIPSAGE PARE-CHOCS

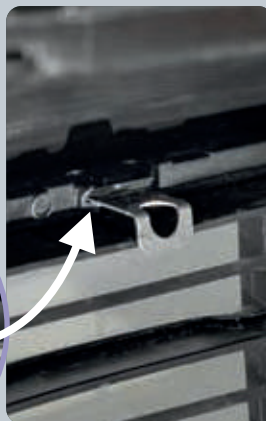

076518



x15  
076525

**NEW**



**STATION DE SOUDAGE DES PLASTIQUES - Plastic welding station - Kunststoff-Schweißset**



320 W - 230 V, 1~50 Hz  
 Temperature : 160 < 480°C  
 ⚡ 3.4 kg  
 Length of hose : 1 m  
 Air flow : 24 l/min

Station seule  
 - Station only  
 064072

**OPTION**

Trolley SPOT 600  
 053533



Ø 5 mm 066694  
 Ø 8 mm 066700



<p>baguettes plastique 440 mm</p>	PP / EPDM	▲ 4 mm x 10	066304
		■ 6 mm x 10	067622
	ABS	▲ 4 mm x 10	071322
		■ 8 mm x 10	071339

	PP/EPDM			
	4mm (x10)	6mm (x10)	8mm (x10)	
064072	✓			
070974		✓		

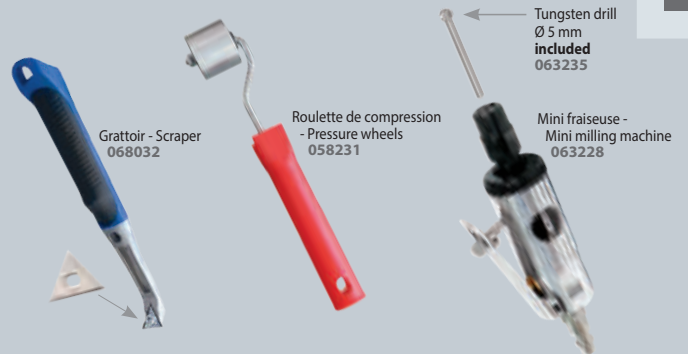

**KIT DE SOUDAGE DES PLASTIQUES - Welding Kit for Plastics - Kunststoff-Schweißset**



1 600 W - 230V - 50/60 Hz  
 max. 230 l/min  
 ⚡ 1.3 kg / L: Ø100 x 300mm,  
 poignée Ø 56mm.

057678

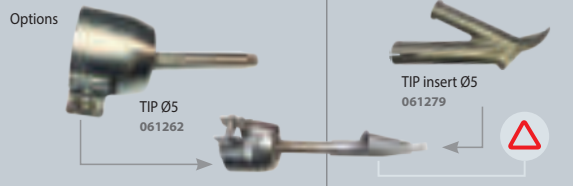
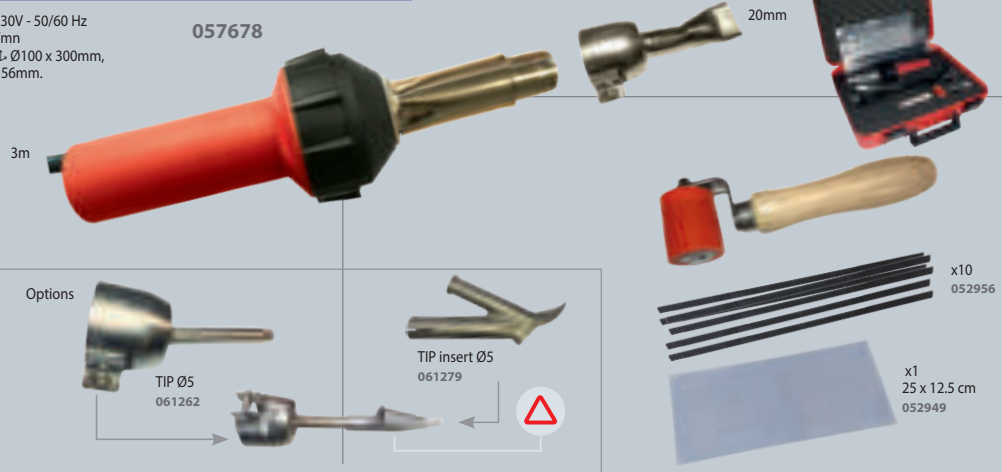

**COFFRET DE RÉPARATION DES PLASTIQUES AUTOMOBILES - Brazing automotive plastics repair kit - Kunststoff Reparatur Set**



052932

MADE IN BELGIUM



x10 052956

25 x 12.5 cm x2 052949

057258

052963

## GYS HAND TOOLS - Ausbeulwerkzeug

● **FULL PACK =**  
061637



+ ● **MEDIUM PACK**  
051133

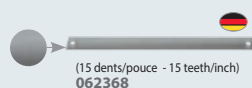
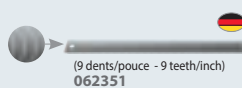

## PLANISHING HAMMER BLACKTEC®

077270

Manche en caoutchouc -  
Rubberised gripping

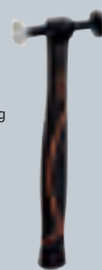

MADE IN GERMANY

Corrosion resistant



## OUTILS DE FORME - Forming tools - Formgebungswerkzeuge

051195



## KIT MARTEAUX ET TAS - Planishing Kit for Car Body (Set of 3 Hammers + 4 Dollys) - Karosseriehammer & Handfaust Kit



40 x 40 mm  
70 x 90 mm  
1.4 kg  
061408



117 x 57 mm  
1.2 kg  
061415

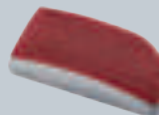

117 x 57 mm  
1.2 kg  
061422



## OUTILS DE DÉGARNISSAGE ET RACLAGE - Set of 30 Tools for scraping/sanding and paint removal - Polster & Schaber Kit

057616

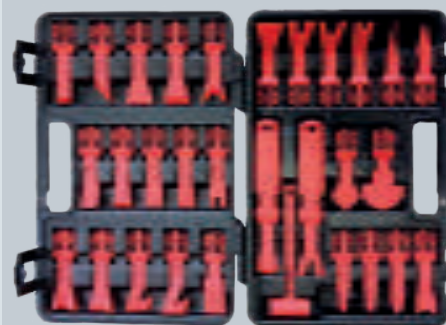

## BURINS

- Hand Chisel for Car Body  
- Meißel für Karosserie

26 x 7 mm  
057586

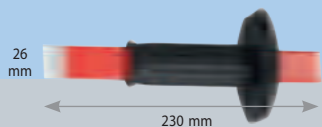

60 x 11 mm  
057593



## LOT DE 3 BURINS DE SÉPARATION

ÉLÉMENTS COLLÉS - Set of 3 chisels - 3 Meißel

076754

NEW



## JEU DE 4 BURINS EN NYLON

- Set of 4 nylon chisels - 4 Kunststoffmeißel

054745

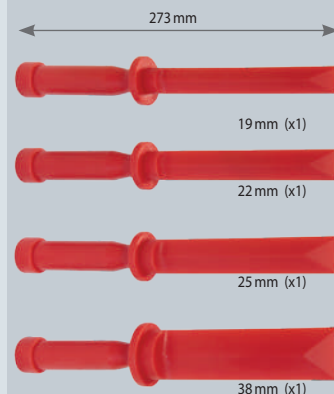

## COUTEAUX RACLOIRS

- Set of 3 scraping knives

061439



**JAUGES DE PROFIL - Contour Gauge - Konturenlehre**

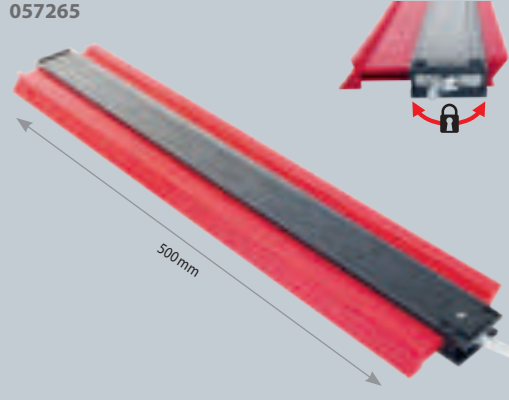

**JAUGES DE POSITIONNEMENT - Gapping gauges - Spaltmaßlehre**

x2  
054752



**OUTIL DE REMISE EN FORME PASSAGE DE ROUE - Fender roller tool set**

060791

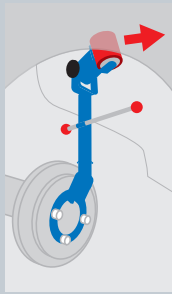

**REDRESSEUR DE CHARNIÈRE DE PORTE - Fixed Hinge Bending Tool**



051102  
Redresseur de charnière de porte  
- Door hinge straightener  
- Türgelenausrichter

**PINÇES DE MAINTIEN BORD À BORD - Positioning clamp - I-Stoß-Lehre**

043190  
(x4)

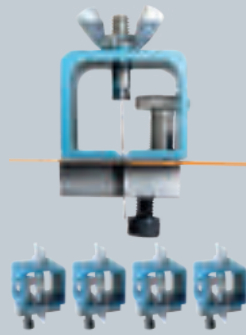

**PINÇES MICRO-GRIP - Micro-grip clamps**

061330  
(x4)

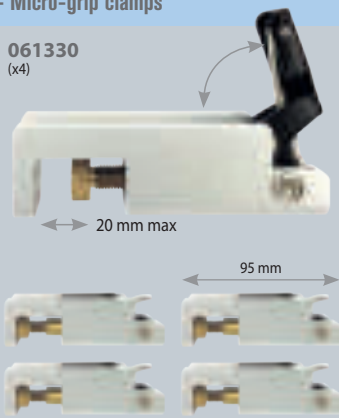

**PINÇES ÉTAU À BEC PLAT - Flat noze lock-grip pliers**

062719

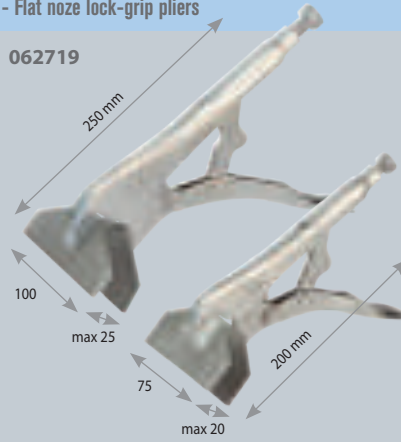

**SERRE-TÔLES - Temporary fasteners manual mounting**

(x10)  
Ø 2,4 mm

069664

(x10)  
Ø 4,0 mm

069671

(x10)  
Ø 4,8 mm

069688

(x10)  
Ø 6,4 mm

069695

**PINÇES AXIALES - Axial-grip pliers**

050242

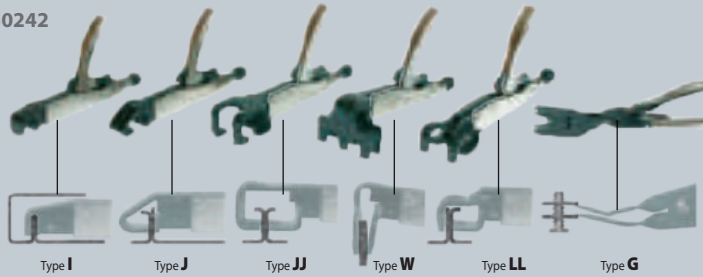

280 mm  
061378



610 mm  
061354



460 mm  
061361



Flat noze - 610 mm  
061347



**PINÇES ÉTAU MONO SERRAGE - Lock-grip pliers**

Flat noze - 460 mm  
050112

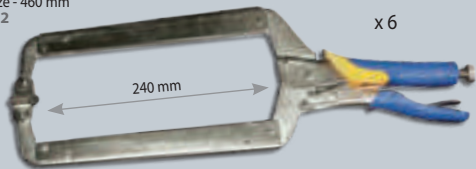

KIT:  
050266

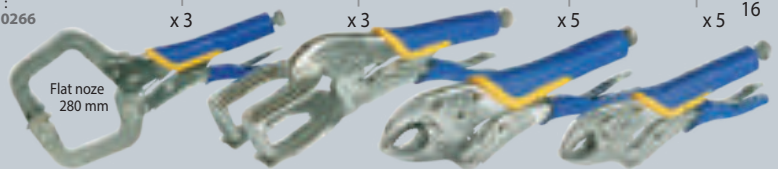



## MINI-MEULEUSE - Mini disc sander - Druckluftschleifer

051829



Speed adjustment

Ø 75 mm

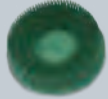

Included (x1) 052468

Speed rpm	Power W	dB	Air consumption l/min	Air pressure bar	cm	kg
18000	200	83	171	6.2	12	0.7

058248

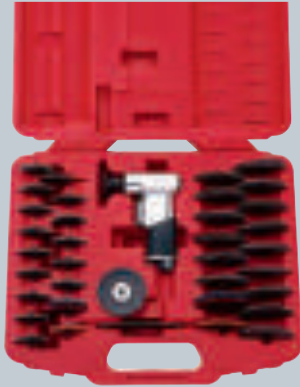

x2 Ø  
Ø 50 & 75 mm

Speed rpm	Power W	dB	Air consumption l/min	Air pressure bar	cm	kg
15000	84	91	6.2	10	0.6	



MINI-FLEXIDISC LAMELLES ZIRCON  
Ø 50 mm  
K 40 (x10) 058255  
K 60 (x10) 058262  
K 80 (x10) 058279

## MEULEUSE D'ANGLE - Long Handed Angle Grinder - Druckluft-Winkelschleifer

057753

Ø 100 mm

± 1.6 mm, x5  
057883

± 0.8 mm, x5  
058217



Speed rpm	Power W	dB	Air consumption l/min	Air pressure bar	cm	kg
14000	84	113	6.2	37	1.7	

## MINI-MEULEUSE À RENVOI D'ANGLE - Mini Angle Grinder - Mini-Druckluftwinkelschleifer geräuschgedämpft

051867

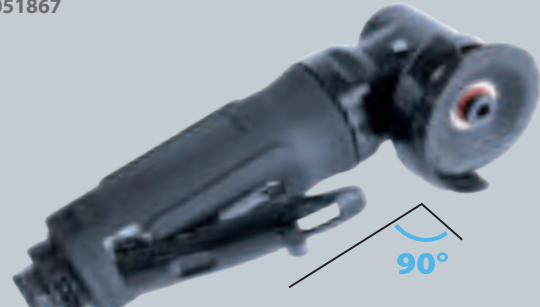

Ø 50 mm

90°



(x1) 052772

Speed rpm	Power W	dB	Air consumption l/min	Air pressure bar	cm	kg
15000	200	86	85	6.2	18	0.75

## PONCEUSE À BANDE À TÊTE ORIENTABLE - Air belt sander - Druckluft Bandschleifer

060906

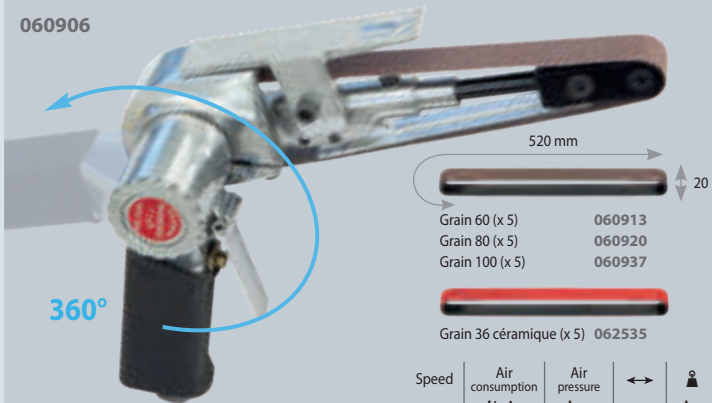

360°

520 mm

20

Grain 60 (x 5) 060913

Grain 80 (x 5) 060920

Grain 100 (x 5) 060937

Grain 36 céramique (x 5) 062535

Speed rpm	Air consumption l/min	Air pressure bar	cm	kg
16000	171	6.3	34	1.2

## SCIE COUPE TÔLE DROITE ET LIME - Saw for Straight Cut and File - Druckluftsäge und Feile

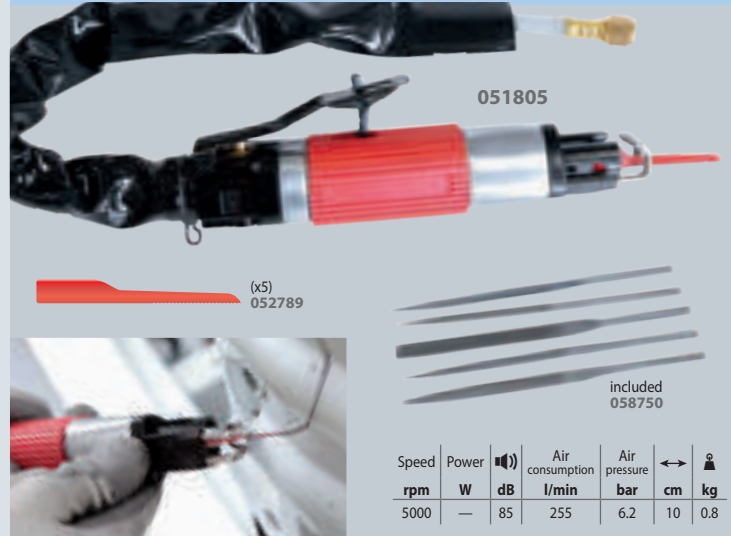

051805

(x5) 052789

included 058750

Speed rpm	Power W	dB	Air consumption l/min	Air pressure bar	cm	kg
5000	—	85	255	6.2	10	0.8

## PONCEUSE À BANDE À TÊTE ORIENTABLE - Air belt sander - Druckluft Bandschleifer

052819



360°

330 mm

10 mm

Grain 80 (x 10) 052833

Grain 36 céramique (x 20) 062528

Speed rpm	Air consumption l/min	Air pressure bar	cm	kg
16000	171	6.3	26	0.9

## MINI-FRAISEUSE À RENVOI D'ANGLE - Mini Angle Milling Machine - Mini-Winkelschleifer

051836



90°

Speed rpm	Power W	dB	Air consumption l/min	Air pressure bar	cm	kg
18000	500	81	85	6.2	18	0.7

## PERCEUSE MANDRIN AUTOMATIQUE - Automatic Mandrel Drill - Druckluftbohrmaschine m. Schnellspannfutter

051799



Ø 13

Speed rpm	Power W	dB	Air consumption l/min	Air pressure bar	cm	kg
800	300	92	170	6.2	18	0.9

## COFFRET DÉCAPEUSE PNEUMATIQUE - Pneumatic surface remover Kit - Drucklufttroster-Box inkl. Zubehör

051775



Roue gomme  
115 x 14 mm  
051874

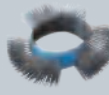

Brosse souple  
Brins droits  
0.5 mm  
103 x 23 mm  
052598



Roue à décaper  
115 x 14 mm  
051843



Brosse dure  
Brins incurvés  
0.7 mm  
103 x 23 mm  
051812



Adaptateur  
pour brosse  
051768

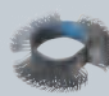

Brosse souple  
Brins incurvés  
0.5 mm  
103 x 23 mm  
051850

Speed rpm	Power W	dB	Air consumption l/min	Air pressure bar	↔ cm	⚖ kg
4000	500	86	102	6.2	280	1.2

## PINCE À SOYER ET À TROUVER, Ø5MM PNEUMATIQUE - Pneumatic flange / ø5 mm punching tool - Pneumatische Loch- und Absatzzange Ø 5 mm

052543

2 in 1



## MINI FRAISEUSE - Mini milling machine - Mini-Schleifer

063228

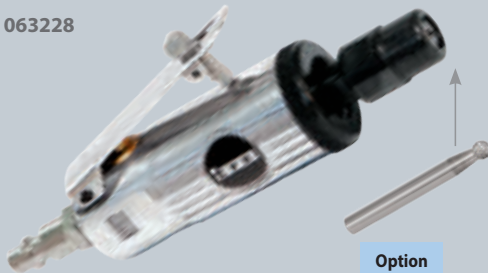

Option

Tungsten drill Ø 6 mm  
054172

## DÉPOINTEUSE POUR CORDON LASER ACIER

- Laser cord metal sheet cutter (nibbler)  
- Trennwerkzeug für Lasernähte

054165



Ø 6 mm

STEEL  
Included  
054172

## OUTIL DE POINÇONNAGE

OBLONGS - Punching tool for oval  
holes - Langlochkarosserieblechzange



2.2 kg

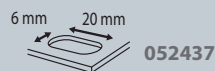

052437

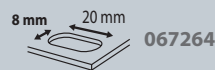

067264

## BODY ZIPPER - Sertisseuse pneumatique Pneumatic Crimper - Druckluftkantenformer

056930



MADE IN  
HIGH  
QUALITY  
POLAND



total thickness  
a b x=2a+b

Air pressure bar	↔ cm	⚖ kg
5	28	2.1

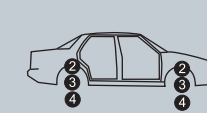

## DÉPOINTEUSE - Spot remover - Druckluft-Schweißpunktbohrer

SPOT DRILL  
050464



360°

Ø 8

Included:  
Tungsten Carbide Ø 8 for BORON/UHSS  
(x1)

HIGH  
QUALITY

Forets de dépointage - Spot remover drill - Schweißpunktfräse  
Tungsten Carbide for BORON/UHSS



	Ø 8 mm	Ø 9 mm	Ø 10 mm
3-edge	053069	069763	053076
4-edge Efficiency ++ Durability ++	059849	069770	

Speed rpm	Power W	dB	Air consumption l/min	Air pressure bar	↔ cm	⚖ kg
800	400	85	140	6.5	35	2.3



Youtube

PACK  
SPOT DRILL + 140 mm  
061460

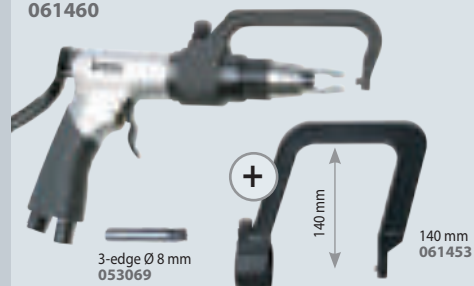

3-edge Ø 8 mm  
053069

+

140 mm

140 mm  
061453

**PISTOLET ANTISTATIQUE**

- Antistatic gun - Pistola antistatica - Pistola antiestática

**NEW**

**077010**

Position correcte des particules de métal après ionisation  
 - Correct metal particles positioning, with ionisation  
 - Posizionamento corretto delle particelle con ionizzazione  
 - Posicionamiento correcto de las partículas metálicas después de la ionización



included:



charger



support

**DÉTECTEUR ÉPAISSEUR DE PEINTURE**

- Film coating thickness gauge

**059856**

Measurement range : 0 - 1.80mm  
 Resolution : 0.01mm / 1mm  
 Measurement error : +/- 0.03 mm  
 Power Supply : 2x 1.5V AAA batteries (included)  
 Overall dimensions : 62 x 30.5 x 105 mm

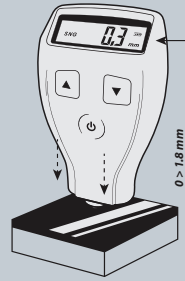

**PONÇEUSE / POLISSEUSE ÉLECTRIQUE - Electric Sander & Polisher**

- Elektro-Polier-Schleifer

**057999**

Orbital 5.0 mm  
 ↳ 303 x 101 mm  
 1.21 kg  
 Speed : 4000, 7000, 9000 10000 rpm  
 AC-in 220V - 230V / 50 - 60Hz

Light weight

& Compact

(( No vibration ))

Speed control



Ø 35

Ø 152 mm

**ASPIRATEUR PNEUMATIQUE POUR POUSSIÈRES ALU (ATEX)**

- Pneumatic aluminium dust atex vacuum cleaner

**058866**

Dust container capacity : 25 l  
 Working compressed air pressure : 7 bar  
 Compressed air consumption at 6 bar : 800 l/min  
 Suction connection diameter size : 50 mm  
 Max suction capacity : 150 m³/h  
 Max vacuum level : 2000 mm H₂O  
 Recommended compressor power : 7.5 HP

↳ 74 x 45 x 45 mm  
 ⚖ 18 kg



**058293**

Power supply : 230V / 50Hz  
 Power : 1400W (max 2000W)  
 Max. vacuum : 170 mbar  
 Air flow : 2700 l/mn  
 Drum capacity : 30 L  
 Drum material : stainless steel  
 ↳ 380 x 380 x 700 mm  
 ⚖ 7 kg

Manual or automatic



4m  
 Input Ø 32 mm  
 Mains cable length 4.5m



included  
 Filtre - Filter  
 075405



included  
 Sac à poussières - Filter bag  
 Capacity 5 kg  
 x5  
 058880



5 m  
 Output Ø 29 mm  
 Input Ø 35 mm





**INNOVATIVE SUCTION SYSTEM**

Depression **1150 mm H2O**  
 Air flow **600 l/min**  
 Air consumption **340 l/min**

Pression ponçeuse ajustable - Adjustable sander pressure  
**5 bar max**

350 x 800 x 400  
 21 kg



**ATEX norm**  
 Group II - Category 3

- ✓ **ROBUST**
- ✓ **QUICK & SAFE**
- ✓ **LOW AIR CONSUMPTION**  
 (5 bar)
- ✓ **NO ELECTRIC MOTOR**
- ✓ **ENERGY SAVING**

Rangement pour disques de ponçage\*  
 - Sanding discs box\*  
 \*disques de ponçage non inclus - discs box not included



**Grande maniabilité et stabilité**  
 - High maneuverability and stability

**EASY ACCESS**

**Aucune maintenance**  
 - Maintenance free



**Consumables**



Sac à poussières - Filter bag  
 Capacity 5 kg  
**Included x1**  
 x 5  
 058880

Ponçeuse non fournie  
 - Sander not included



5 m  
 Ø 29 mm

**Option :**  
 10m  
 Ø 29 mm  
 076013



Included Earth clamp safety



Ponçeuse pneumatique  
 - Pneumatic Sander  
**MIRKA PROS 650CV**  
 Ø 150 mm  
**071346**

**2 MODELS**

**GYSDUST EXTRACTOR**

**MANUAL**

Démarrage manuel  
 - Manual start

071353



**GYSDUST SELF EXTRACTOR**

**AUTOMATIC**

Démarrage automatique  
 - Automatic start

077058



**NEW**  
 12 2022

**LAMPES BALADEUSES - Hand lamps - Handleuchte**

**Lampe BALADEUSE TRIPODE 250 L**

**100-250 lumens (x3)**

3 x 1 W COB LED  
 3 x 3.6 V - 300 mAh  
 AAA rechargeable, Ni-MH  
 USB charging (6h)  
**operating time**  
 High position : 1 h  
 Low position : 3 h  
 Flashing : 5 h

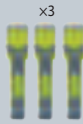

↳ 260 x 100 x 100 mm

059955



**Lampe BALADEUSE 400 L**

**400 lumens**

COB LED  
 Li-ion  
 Charging time : 8h  
**operating time**  
 High position : 2.5 h  
 Low position : 5 h  
 Top light (1 W) : 6 h

↳ 230 x 65 x 40 mm

059153



**Lampe BALADEUSE ÉTANCHE 400 L**

**200-400 lumens**

COB LED  
 3.7 V - 2000 mAh Li-ion  
 USB charging (4/6 h)  
 mains charger not included  
**operating time**  
 High position : 2 h  
 Mid position : 4 h  
 Top light (4 W) : 3 h

↳ 285 x 65 x 65 mm  
 IP 56

059948

Étanche - Waterproof



**Lampe BALADEUSE PRO 600 L**

**250-600 lumens**

COB LED, 80 CRI  
 3.7 V - 2200 mAh Li-ion  
 micro USB charging (3.5 h)  
**operating time :**  
 High position : 1.5 h,  
 Mid position : 4.5 h,  
 Top light (100 lumens) : 10 h

↳ 190 x 56 x 29 mm  
 IP 54  
 210 g

060883



**Lampe AMBIANCE 360° PORTABLE 1000 L**

**60-1000 lumens**

>80 CRI SMD LED  
 6500 K  
 3.7 V - 5200 mAh Li-ion  
 USB charging (4.5h)  
 USB power supply  
**operating time** 2 > 27 h

↳ 260 x 75 x 75 mm  
 IP 54  
 450 g

059764

USB charging /Power supply



**Ambiant light**

**LAMPES SOUS CAPOT - Under bonnet lamps - Leuchte für Motorhaube**

**Lampe SOUS CAPOT 600 L**

**500-1000 lumens**

120 COB LED  
 3.7 V - 4000 mAh Li-ion  
 charging time : 10/12 h

**operating time**  
 High position : 4 h  
 Low position : 8 h

1.7 kg

059962



130 > 180 cm

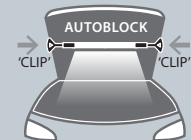

**Lampe SOUS CAPOT 800 L**

**250-800 lumens**

120 COB LED  
 3.7 V - 4000 mAh Li-ion  
 charging time : 10/12 h

**operating time**  
 High position : 3 h  
 Low position : 6 h

058002  
 058316

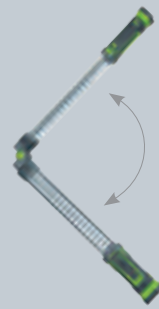

130 cm



**LAMPES D'INSPECTION - Inspection lamps - Inspektionslampen**

**Lampe INSPECTION FRONTALE 280 L**

**100-280 lumens**

3 W COB LED, 80 CRI+, 6500 K  
 3.7 V - 1500 mAh Li-po  
 micro USB charging  
 mains charger not incl.  
**operating time**  
 High position : 2 h  
 Low position : 6 h  
 IP 65  
 110 g  
 ↳ 78.5 x 47.5 x 42 mm

060845



**Lampe INSPECTION MINI 200 L**

**120-200 lumens**

COB LED, 80 CRI, 6500 K  
 3.7 V - 700 mAh Li-ion  
 micro USB charging (2.5 h)  
 mains charger not included  
**operating time**  
 High position : 1.5 h  
 Low position : 4 h  
 Top light : 3.5 h  
 IP 20  
 76 g, ↳ 174 x 27.5 x 28 mm

060852

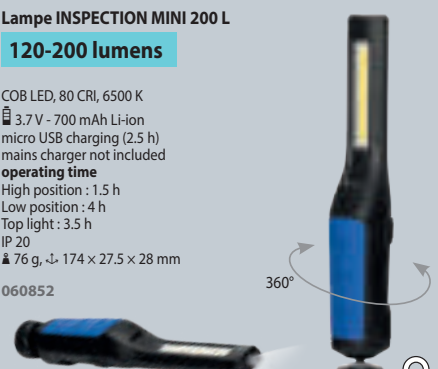

**Lampe INSPECTION PRO 600 L**

**0-600 lumens**

COB LED  
 6500 K  
 3.7 V - 2600 mAh Li-ion  
**operating time**  
 1.5 > 15 h

↳ 380 x 40 x 45 mm  
 300 g

057760  
 058309

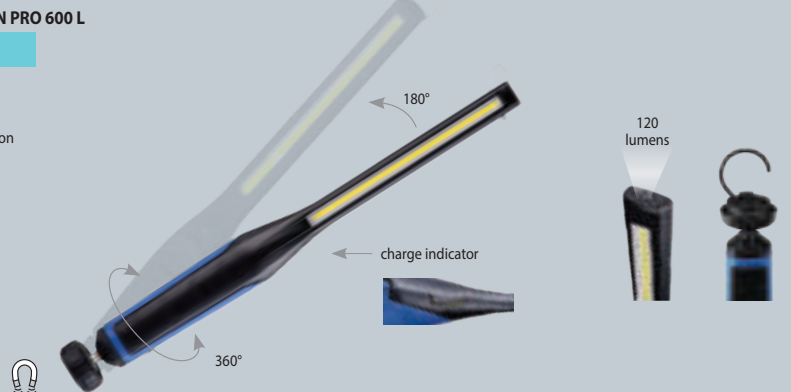

120 lumens

360°

Lampe sur TRÉPIED 1800 L

**1800 lumens**

3x 55 COB LED  
total 165 LED  
1.8 m power cord  
059146

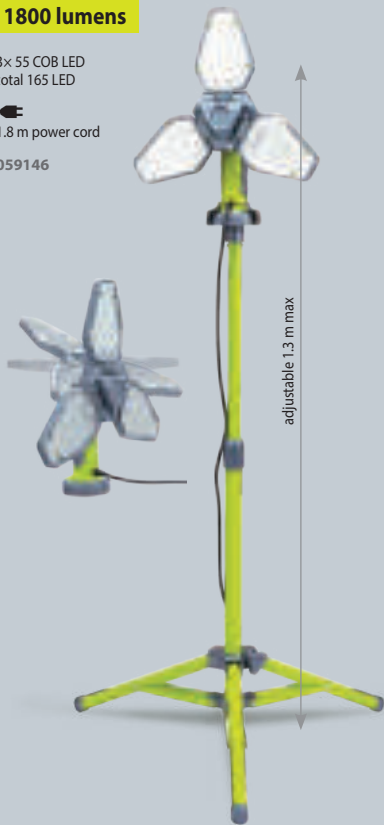

Lampe sur TRÉPIED 3000 L

**3000 lumens**

35 W COB LED  
2 m power cord  
IP 44  
059979



Lampe sur TRÉPIED 4000 L

**4000 lumens**

3x 20 COB LED,  
total 60 LED  
3 m power cord  
059986



CONTRÔLE DES COULEURS - Detailing & colour match - Fabnpassung & Aufbereitung

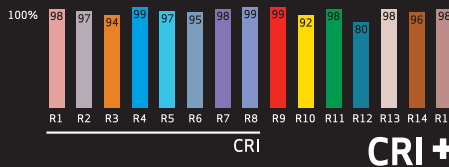

**4500 K**

**400 lumens**

**SUNCOLOR 1**  
COB LED, CRI > 95, 1100 lux  
3.7 V - 2600 mAh Li-ion  
USB charging  
operating time : 3 h  
↓ 190 x 56 x 29 mm  
290 g  
IP 65

058477



**3 COLORS**

**2700 - 4500 - 6500 K**

**350-420-450 lumens**

**SUNCOLOR 3**  
COB LED, 96 CRI+  
3.7 V - 2600 mAh Li-ion  
micro USB charging (4 h)  
operating time : 2.5/4 h  
IP 65  
↓ 190 x 56 x 29 mm, 290 g

060838



**5 COLORS**

**2700 - 3500 - 4500 - 5500 - 6500 K**

**500-1000-2000 lumens**

**SUNCOLOR 5**  
COB LED, 96 CRI+  
11.1 V - 4400 mAh Li-ion  
charger 110/240 V, 5 m cable, 15 V, 1.5 A  
charging time : 3.5 h  
operating time  
High position : 2 h, Mid : 4 h, Low : 8 h  
IP 65  
↓ 225 x 200 x 70 mm, 1.2 kg

060876

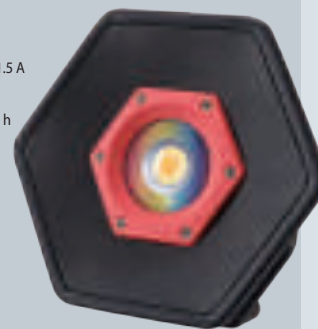

**5 COLORS**

**2500-3500-4500-5500-6500 K**

**250-500 lumens**

**SUNMATCH 3**  
COB LED, 96 CRI+, 700-1400 lux  
3.7 V - 2600 mAh Li-ion, USB charging  
operating time :  
High position : 2 h, Low position : 4 h  
IP 65  
↓ 204 x 89 x 81 mm, 270 g

061651



**SÉCHAGE UV - UV CURING**

**UV LED λ 395-400 nm**

**Irradiance 6-15 mW/cm<sup>2</sup>**

**NOVA-UV S**

3.7 V - 5400 mAh Li-ion  
USB charger, 1 m cable, 5 V, 2 A  
charging time : 3.5 h  
curing area : Ø 20 cm  
operating time 1.5 h  
IP 67  
↓ 163 x 63 x 163 mm

061620







**TRÉTEAUX - Frames support - Klappböcke**



040601  
100.5 x  
112 cm -  
5.5 kg  
35 x 95 x  
106 cm

Ø28mm

**4 pieds coudés**  
Idéal sur caillbotis  
- Bent feet for grating  
- Abgewinkelte Standfüße:  
Sicherer Stand auf Gittern u.ä.



Chaînette réglable  
- Adjustable catenary



Mousse de protection  
- Protecting foam



Antidérapants  
- Non-slip base



Ø32mm

040250  
100 x 105 cm - 7kg  
32 x 10 x 106 cm



Ø32mm

**Léger et très maniable**  
Spécial travaux à l'horizontal  
- Light and easy to handle  
- Ideal for horizontal works  
- Speziell geeignet für Arbeiten  
in horizontaler Position

040304  
104.5 x 108.8 cm - 8.1kg  
32 x 10 x 106 cm



Ø32mm

**4 ventouses**  
Dépose vitrages  
- Suction pad for glazing  
- Gummiteller zur Fixierung  
von Glasscheiben

040311  
104.5 x  
117 cm -  
8.1kg  
32 x 10 x  
106 cm

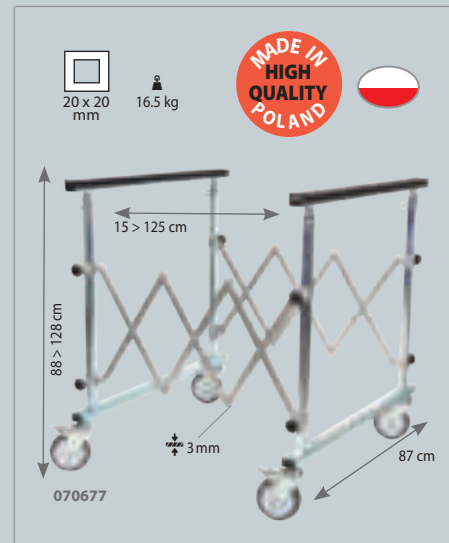

20 x 20  
mm

16.5 kg

MADE IN  
HIGH  
QUALITY  
POLAND



15 > 125 cm  
88 > 128 cm  
3 mm  
87 cm  
070677

**SUPPORT PARE-CHOC - Rotary element support  
Lackierstände für Stoßstange, einstellbar**

052376  
91 x 105 cm - 7.6 kg  
60 x 11 x 75 cm



Adapté aux coques de rétroviseurs  
- Adapted to wing mirror covers  
- Geeignet für Außenspiegel

059825

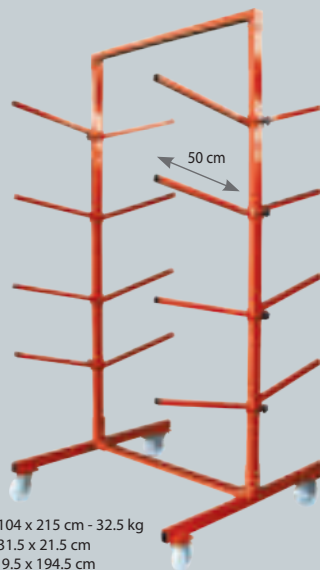

106 x 104 x 215 cm - 32.5 kg  
112 x 31.5 x 21.5 cm  
+ 12 x 9.5 x 194.5 cm

059832

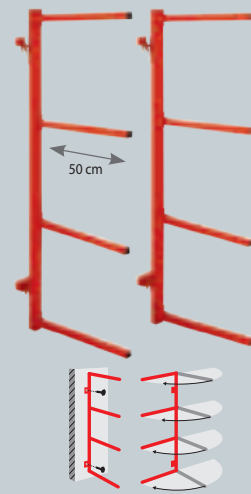

50 x 150 cm - 13 kg  
152 x 15.5 x 111.5 cm

**SUPPORT ÉLÉMENT ROTATIF - Rotary element support -  
Lackierstände für Stoßstange, einstellbar**

052611  
200 x 101 cm - 17.5 kg  
35 x 15 x 110 cm  
Made in China

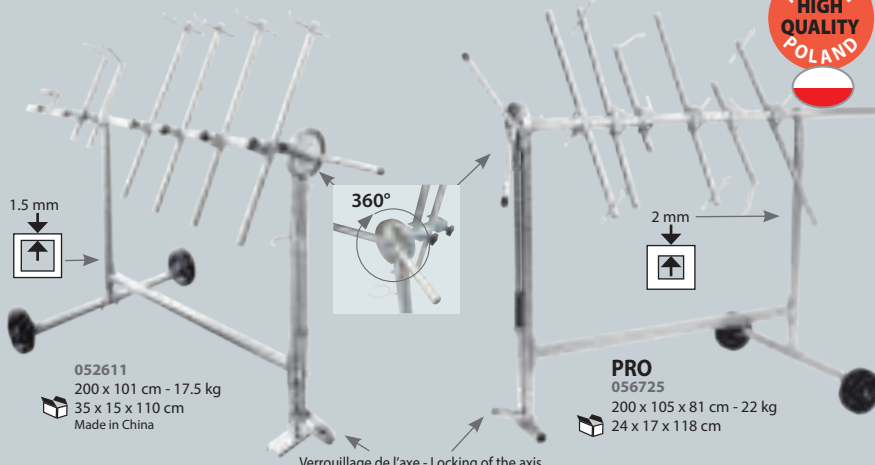

1.5 mm

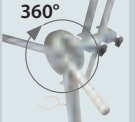

360°

2 mm



**PRO**  
056725  
200 x 105 x 81 cm - 22 kg  
24 x 17 x 118 cm

Verrouillage de l'axe - Locking of the axis  
- Verriegelung der Achse

MADE IN  
HIGH  
QUALITY  
POLAND

**CHARIOT EXTENSIBLE POUR  
ÉLÉMENTS DE CARROSSERIE -  
Extendable support - Ausziehbarer Wagen**

061507  
max 150 kg

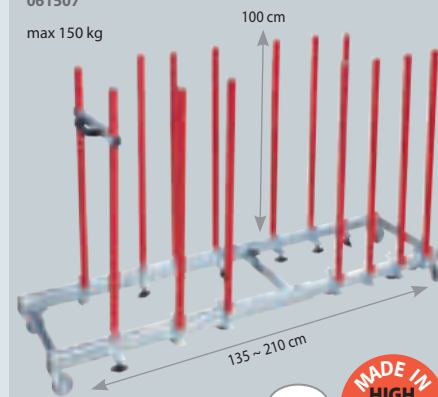

100 cm

135 ~ 210 cm

26 kg  
114.5 x 42 x 13.5 cm

MADE IN  
HIGH  
QUALITY  
POLAND



### CHARIOT DE LUXE MAROUFLAGE

- Premium masking machine - Abdeckpapier-Ständer

**MADE IN HIGH QUALITY POLAND**

**X 5** (not included)  
rouleaux de papier  
- Papierständer  
- Paper roll  
30 > 120 cm

057333  
150 x 133 x 62 cm  
32 kg  
152 x 17 x 29 cm

OPTION  
Ø 40 mm  
x 6  
058897

Ø 75 mm  
Ø 250 mm

### CHARIOT DE MAROUFLAGE

- Masking machine - Abdeckpapier-Ständer

**MADE IN HIGH QUALITY POLAND**

**X 3** (not included)  
rouleaux de papier  
- Papierständer  
- Paper roll  
30, 60, 90 cm

056954  
150 x 62 x 110 cm  
- 12 kg  
122 x 29 x 17 cm

Ø 75 mm  
Ø 250 mm

### CHARIOT DE STOCKAGE

- Storage trolley - Lagerrollwagen

040243

71 x 90  
x 197 cm  
41 kg  
x2:  
90 x 6 x 147 cm  
+ 97 x 74 x 24 cm

### TIGES DE BLOCAGE - Flap Lock

056732

30 > 115 cm

### TABOURET - Round Stool with Tool Storage - Werkstatt-Rollhocker

057555  
38 x 38 x 44 cm - 6 kg  
40 x 40 x 18 cm

max : 50 cm  
min : 38 cm

### SERVANTE 3 PLATEAUX - Workstation 3 shelves

068056

65 kg max  
65 kg max  
65 kg max

835 mm  
390 mm  
800 mm

### SERVANTE PREMIUM 5 TIROIRS - Workstation Premium 5 drawers

076143

**NEW 02 2023**

1000 mm  
560 mm  
940 mm

### CHARIOT DE VISITE - Mechanics Creeper With Tilting Headrest - Werkstatt-Rollliege

057548  
102 x 43 x 11 cm  
7,2 kg  
11 x 44 x 13 cm

### MARCHE PIED - Folding Step Stool (Aluminium) - Arbeitspodest klappbar

**ALU 150 kg**

057562  
8,2 kg  
102 x 41 x 59 cm

960 mm  
385 mm  
475 mm

### CHARIOT POUR ÉLÉMENTS DE CARROSSERIE - Universal support - Universelle Ständer

066281  
20 kg  
max 80 kg  
Ø 4.5 cm  
Ø 12.5  
115 cm  
70-100 cm

**MADE IN HIGH QUALITY POLAND**

**ALU 150 kg**

058552  
15,5 Kg  
116 x 43 x 17 cm - 16.5 kg

**COUVERTURE ANTI-CHALEUR** - Heat cover - Hitzeschutzdecke - Manta anti-calor - Proteção anti-aquecimento

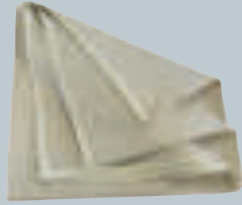

PROTEC 550  
550°C/1000°F - Class M0  
2 m x 2 m - 580 g/m<sup>2</sup>  
050495



PROTEC 1200  
1200°C/2200°F - Class M0  
1.75 m x 1.5 m - 1200 g/m<sup>2</sup>  
050204



PROTEC 1300  
1300°C/2400°F - Class M0  
XL : 2 m x 1.8 m 620 g/m<sup>2</sup>  
053595

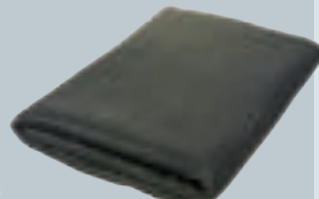

PROTEC 1300L  
1300°C/2400°F  
XL : 2 m x 1.8 m 427 g/m<sup>2</sup>  
060500

**JEU DE 2 AIMANTS**  
- Set of 2 magnets -  
Schweißmagnet



(x2)  
052291

**COUVERTURE MAGNÉTIQUE** - Magnetic cover - Magnetschutzdecke



1.06 m x 0.6 m  
061446

**RIDEAU DE SOUDAGE** - Welding curtain and frame - Schweißerschutzwand

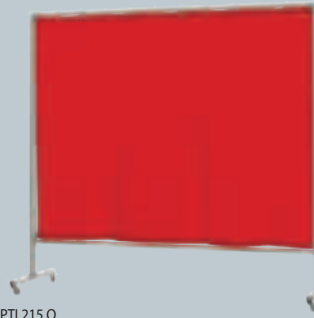

OPTI 215.0  
Orange CE - 2 x 2.15 m  
EN 25980 - 2015/01  
060470



OPTI 200G  
Green T9 - 2 x 2 m  
EN 25980 - 2015/01  
060463

**MASQUES RESPIRATOIRES** - Respiratory masks - Atemschutzmaske - Máscaras respiratorias



FFP3 - EN 140 / EN 143 / EN 166  
(x1) Size M/L  
037021



FFP3 - EN 140 / EN 143  
(x1) Size M/L  
037014



Étui / Case  
037045



FFP3 - EN 143 : 2000 P3  
Anti poussières  
/ Anti odeurs  
037038

**LUNETTES DE PROTECTION**  
- Protection goggles - Schutzbrillen

EN 166



Shade/IR0  
042810



Shade/IR0  
042827



Shade/IR5  
042841



Shade/IR0  
047778



Shade/IR0  
047792



Shade/IR0  
042865



Shade/IR0  
047839

**GANTS** - Gloves - Handschuhe - Guantes



Anti coupure  
- Anti-cut  
T9  
045897



EN388  
4342



✓ écran tactile  
- touch screen friendly  
Anti coupure  
haute résistance  
High resistance anti-cut  
EN 420  
EN 388:4121  
T9: 045910  
T10: 045927



Anti coupure  
haute dextérité  
- High dexterity  
anti-cut  
EN 420  
EN 388:1121  
T9: 045903  
T10: 045934



T10  
064188

EN420  
2003



EN388  
2003



Heavy Duty T10  
(MMA - MiG - Plasma)  
045101



EN388  
4244



EN 407  
424X4X  
EN12477  
Class : A1



Gants PRO TIG  
T10  
045194



EN388  
2122



EN 407  
322X2X  
EN12477  
Class : A1



Gants de soudage  
renforcés - Reinforced welding  
gloves  
T10  
045873



EN388  
4244



EN 407  
424X4X  
EN12477  
Class : A1



Gants PRO TIG EXTRA  
T10  
045323



EN388  
2011XX



EN 407  
41313X  
EN12477-B  
EN 420

**TABLIER CUIR MULTI-USAGE**  
- Multi-use leather apron - Delantal  
de cuero multi-uso - Mehrzweck-  
Lederschürze



PRO  
045217





ÉCRAN FACIAL AVEC SERRE-TÊTE  
- FACE SHIELD WITH HEADBAND  
068018



GANTS ISOLANTS (T10)  
- INSULATING GLOVES (T10)  
068025



Coffret de 25 outils isolés 1000V - 25 pieces insulated tools 1000V -  
Box mit 25 isolierten Werkzeugen 1000V  
066489



Douilles 7/8/10/12/14/15/17/19/22 mm - 7/8/10/12/14/15/17/19/22 mm sockets	x 9
Pince universelle de 175 mm en chrome vanadium - 175 mm universal pliers in chrome vanadium	x 1
Pince coupante 150 mm en chrome vanadium - Cutting pliers 150 mm in chrome vanadium	x 1
Cluqiet en 3/8" - 3/8" ratchet	x 1
Rallonge 100 mm - Extension 100 mm	x 1
Poignée en T - T-handle	x 1
Clés plates à fourches 7/8/10/12/14/17 mm - Open ended wrenches 7/8/10/12/14/17 mm	x 6
Couteau pour câble - Cable knife	x 1
Tournevis Philips PhH1x100/PhH2x100 mm - Philips PhH1x100/PhH2x100 mm screwdriver	x 2
Tournevis plats 5.5x125/4x100 mm - Flat screwdriver 5.5x125 / 4x100 mm	x 2



Kit pour le balisage de la zone d'intervention  
- Kit for marking the area of intervention  
- Kennzeichnungsset für Hochvolt-Bereiche  
064409



Balise de signalisation rouge et blanche - Red and white warning pole	x 4
Chaîne de délimitation rouge et blanche - Red and white bounding line	x 1
Pancarte de signalisation "Danger, zone de travail VEH" - Sign board "Danger, working area EHV"	x 2



PANTALON - Trouser - Hose



	98% cotton, 2% antistatic
	<b>S</b> (40/42) 046368
	<b>M</b> (44/46) 046375
	<b>L</b> (48/50) 046382
	<b>XL</b> (52/54) 046399
	<b>XXL</b> (56/58) 046412

VESTE - Jacket - Jacke



	98% cotton, 2% antistatic
	<b>S</b> (40/42) 046313
	<b>M</b> (44/46) 046320
	<b>L</b> (48/50) 046337
	<b>XL</b> (52/54) 046344
	<b>XXL</b> (56/58) 046351





# BSU & CHARGERS

BATTERY SUPPORT UNIT

Homologations  
Approvals  
Zulassungen



## A FULL RANGE FOR ALL NEEDS



DOWNLOAD  
CATALOGUE



  
**CHARGERS**  
6 - 12 - 24 - 36 - 48 V

  
**STARTERS  
& CHARGERS**  
12 - 24 V

  
**BOOSTERS**  
6 - 12 - 24 V

  
**TESTERS**  
12 - 24 V

  
**ACCESSORIES**  
  
  
**MORE**





French manufacturer  
since 1964



**Tools**

Tel: +32 (0)10 39 51 50 • Fax: +32 (0)10 46 02 78  
info@vbtools.be • www.vbtools.be

Voor technisch advies,  
Pour toutes informations techniques,

**Jonathan Govaers**

Hainaut, Brabant Wallon, Vlaams Brabant, Limburg, Oost-, West-Vlaanderen, Provincie Antwerpen.  
jonathan.govaers@vbtools.be  
0490/11.00.87

**Sebastien Akel**

Province de Namur, Liège, Luxembourg et du Grand-Duché.  
sebastien.akel@vbtools.be  
0490/11.91.95

Distributed by

